

HYDROFLEX®

ΣΩΛΗΝΕΣ ΡΑΚΟΡ

2026



ΑΞΙΟΠΙΣΤΙΑ



ΠΟΙΟΤΗΤΑ



ΑΝΤΟΧΗ



ΣΥΝΕΡΓΑΣΙΑ

Συνδέουμε το αύριο. |

ΣΩΛΗΝΕΣ



ΣΕΛΙΔΑ 1-14

ΡΑΚΟΡ ΠΙΕΣΕΩΣ ΠΡΕΣΣΑΡΙΣΤΑ



ΣΕΛΙΔΑ 15-35

ΡΑΚΟΡ ΠΙΕΣΕΩΣ INTERLOCK

ΣΕΛΙΔΑ 36-39

ΡΑΚΟΡ ΠΙΕΣΕΩΣ ΠΡΕΣΣΑΡΙΣΤΑ ΣΕΙΡΑ 80 CAST

ΣΕΛΙΔΑ 40-47

ΡΑΚΟΡ ΠΙΕΣΕΩΣ ΠΡΕΣΣΑΡΙΣΤΑ ΑΥΤΟΜΑΤΑ QO

ΣΕΛΙΔΑ 48

ΡΑΚΟΡ ΠΙΕΣΕΩΣ ΠΡΕΣΣΑΡΙΣΤΑ ΣΕΙΡΑ 60

ΣΕΛΙΔΑ 49-54

ΡΑΚΟΡ ΙΝΟΧ



ΣΕΛΙΔΑ 55-57

ΜΑΣΤΟΙ ΔΙΑΦΟΡΟΙ B.S.P.



ΣΕΛΙΔΑ 58-62

ΠΕΡΙΣΤΡΟΦΙΚΑ- ΜΕΤΡΗΣΗ ΠΙΕΣΗΣ
βαλβιδες Υδραυλικές

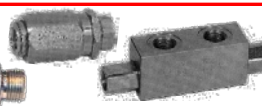

ΣΕΛΙΔΑ 63-67

ΣΙΔΗΡΟΣΩΛΗΝΕΣ-ΣΤΗΡΙΓΜΑΤΑ



ΣΕΛΙΔΑ 68

ΒΑΝΕΣ ΠΙΕΣΕΩΣ-ΤΑΧ/ΣΜΟΙ



ΣΕΛΙΔΑ 69-70

ΤΑΧΥΣΥΝΔΕΣΜΟΙ FASTER



ΣΕΛΙΔΑ 71-75

ΣΦΥΡΗΛΑΤΑ DIN 2391



ΣΕΛΙΔΑ 76-84

ΑΜΕΡΙΚΗΣ U.N.F.



ΣΕΛΙΔΑ 85-91

O.R.F.S.



ΣΕΛΙΔΑ 92-96

ΡΑΚΟΡ ΧΕΙΡ/ΣΑΣ-ΠΕΤΡΕΛΑΙΟΥ
ΡΑΚΟΡ ΑΕΡΟΦΡΕΝΩΝ



ΣΕΛΙΔΑ 97-101

ΡΑΚΟΡ ΦΡΕΝΩΝ ΠΙΕΣΗΣ ΥΓΡΩΝ



ΣΕΛΙΔΑ 102-104

ΡΑΚΟΡ ΑΥΤΟΜΑΤΑ



ΣΕΛΙΔΑ 105-111

ΡΑΚΟΡ ΟΡΕΙΧΑΛΚΙΝΑ



ΡΑΚΟΡ ΑΕΡΟΣ -ΤΑΧ/ΣΜΟΙ

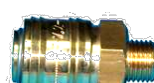

ΣΕΛΙΔΑ 112-108

ΡΑΚΟΡ ΑΕΡΟΣΦΥΡΑΣ



ΒΑΝΕΣ MINI- ΣΦΥΚΤΗΡΕΣ



ΣΕΛΙΔΑ 109-117

ΡΑΚΟΡ AIRCONDITION



ΣΕΛΙΔΑ 118

1 SN ISO 1436-1 SAE 100 R1AT EN 853 GREEN LINE



ΚΩΔΙΚΟΣ	διάσταση	διάσταση	kg/m	bar	€	€+ΦΠΑ
	εσωτερική	εξωτερική		w.p.		
ΣΠ-010005	3\16	11,1	0,160	250		
ΣΠ-010006	1\4	13,0	0,209	225		
ΣΠ-010008	5\16	14,5	0,236	215		
ΣΠ-010010	3\8	17,2	0,313	180		
ΣΠ-010013	1\2	20,1	0,367	160		
ΣΠ-010016	5\8	23,1	0,466	130		
ΣΠ-010019	3\4	27,3	0,555	105		
ΣΠ-010025	1"	35,6	0,950	88		
ΣΠ-010032	1" 1\4	42,1	1,095	63		
ΣΠ-010038	1" 1\2	49,2	1,411	50		
ΣΠ-010050	2"	62,4	1,864	40		

Συνθετικός σωλήνας λαδιού με ενίσχυση μιας σειράς ατσάλινης πλέξης, κατάλληλος για υδραυλικά λάδια, αέρα, νερό.

Θερμοκρασία Λειτουργίας: -40 +125° C

Για τον αέρα max +70° C



2 SN ISO 1436-1 SAE 100 R2AT EN 853 GREEN LINE



ΚΩΔΙΚΟΣ	διάσταση	διάσταση	kg/m	bar	€	€+ΦΠΑ
	εσωτερική	εξωτερική		w.p.		
ΣΠ-020006	1\4	14,6	0,330	400		
ΣΠ-020008	5\16	16,0	0,357	350		
ΣΠ-020010	3\8	18,4	0,463	330		
ΣΠ-020013	1\2	21,5	0,534	275		
ΣΠ-020016	5\8	24,9	0,665	250		
ΣΠ-020019	3\4	29,2	0,895	215		
ΣΠ-020025	1"	37,0	1,253	165		
ΣΠ-020032	1" 1\4	46,4	1,852	125		
ΣΠ-020038	1" 1\2	52,8	2,086	90		
ΣΠ-020050	2"	65,6	2,748	80		

Συνθετικός σωλήνας λαδιού με ενίσχυση 2 ατσάλινων πλεγμάτων, κατάλληλος για υδραυλικά λάδια, αέρα, νερό.

Θερμοκρασία Λειτουργίας: -40 +125° C

Για τον αέρα max +70° C



4SP- 4SH POWERFLEXBio 6000p.s.i. ISO18752

DIN 20023 4SP & 4SH (EN856)



ΚΩΔΙΚΟΣ	διάσταση	διάσταση	kg/m	bar	€	€+ΦΠΑ
	εσωτερική	εξωτερική		w.p.		
ΣΠ-040906	1\4 4SP	17,3	0,47	450		
ΣΠ-040910	3\8 4SP	19,9	0,55	445		
ΣΠ-040913	1\2 4SP	23	0,75	420		
ΣΠ-040916	5\8 4SP	25,9	1,19	350		
ΣΠ-041019	3\4 4SH	31,4	1,47	420		
ΣΠ-041025	1" 4SH	38	2,03	380		
ΣΠ-041032	1" 1\4 4SH	45,8	2,47	350		
ΣΠ-041038	1" 1\2 4SH	51,8	2,86	290		
ΣΠ-041050	2" 4SH	67,6	4,48	280		

Συνθετικός σωλήνας λαδιού με ενίσχυση 4 ατσάλινων πλεγμάτων, κατάλληλος για υδραυλικά λάδια, αέρα, νερό.

Θερμοκρασία Λειτουργίας: -40 +121° C

Για τον αέρα max +70° C



6SP R15 POWERFLEXBio 6000p.s.i. ISO18752



ΚΩΔΙΚΟΣ	διάσταση	διάσταση	kg/m	bar	€	€+ΦΠΑ
	εσωτερική	εξωτερική		w.p.		
ΣΠ-041525	1"	38,6	1,99	420		
ΣΠ-041532	1" 1\4	49,4	3,47	420		
ΣΠ-041538	1" 1\2	56,5	4,48	420		
ΣΠ-041550	2"	71	7,08	420		

Συνθετικός σωλήνας με ενίσχυση 6 ατσάλινων πλεγμάτων, κατάλληλος για υδραυλικά λάδια, αέρα, νερό.

Θερμοκρασία Λειτουργίας: -40 +121° C

Στην διάμετρο 1" έχουμε 4 σύρματα οι υπολοίπες 6σύρματα
Χρήση με ρακόρ τύπου INTERLOCK



Νέα σειρά POWERFLEXBio με μεγαλύτερη ευκαμψία 50% καλύτερη από SAE100 R. Ειδικό εξωτερικό κάλυμα για μέγιστη αντοχή σε περιβάλλον ορυχείων, αντιτριβική αντίσταση, καιρικές συνθήκες, και αντοχή σε φωτιά.

1 SN
2 SN
4SP-4SH
6 SP R15

1 SC SLIM



Συνθετικός σωλήνας λαδιού με ενίσχυση μιας σειράς ατσάλινης πλέξης, κατάλληλος για υδραυλικά λάδια, αέρα, νερό.

-40 +125°C. Για τον αέρα max +70° C

241T SLIMLINE



Συνθετικός σωλήνας λαδιού με ενίσχυση 2 ατσάλινων πλεγμάτων, κατάλληλος για υδραυλικά λάδια, αέρα, νερό.

-40 +125°C. Για τον αέρα max +70° C

R 5



Ελαστικός σωλήνας από συνθετικό λάστιχο, ενισχυμένος με μια σειρά ατσάλινη πλέξη και πανί εξωτερικά, κατάλληλος για λάδια,

**Θερμοκρασία λειτουργίας: -40 +125° C
Για τον αέρα max +70° C**

R 6



Ελαστικός σωλήνας κατασκευασμένος από συνθετικό λάστιχο με ενίσχυση μιας σειράς λινής πλέξης. Κατάλληλος για χρήση για λάδια, καύσιμα, λιπαντικά, επιστροφές λαδιών.

**Θερμοκρασία λειτουργίας: -40 +125° C
Για τον αέρα max +70° C**

3TE τιμονιού



Ελαστικός σωλήνας κατασκευασμένος από συνθετικό λάστιχο με ενίσχυση 2 σειρές λινής πλέξης. Κατάλληλος για χρήση για

150°C 1SN



**Πετρελαικής βάσης υγρά,ορυκτέλαια: +150°C
Αέρας:85°C ΕΩΣ 5/8 +110°C 3/4
Σιλικονούχα ορυκτέλαια: +107°C**

Κατασκευασμένη για αντοχή σε μεγάλες θερμοκρασίες .

1 SC SLIMLINE 121T ISO 11237 EN 857

ΚΩΔΙΚΟΣ	διάσταση	διάσταση	bar	€	€+ΦΠΑ
	εσωτερική	εξωτερική	w.p.		
ΣΠ-011006	1\4	12,1	275		
ΣΠ-011008	5\16	14,1	255		
ΣΠ-011010	3\8	15,6	215		
ΣΠ-011013	1\2	19,5	170		

241T SUPER SLIMLINE- HI-TUFF

ΚΩΔΙΚΟΣ	εσωτερική	εξωτερική	w.p.	€	€+ΦΠΑ
ΣΠ-024006	1\4	13,2	420		
ΣΠ-024008	5\16	14,8	375		
ΣΠ-024010	3\8	17,4	350		
ΣΠ-024013	1\2	20,7	310		
ΣΠ-024016	5\8	23,7	280		
ΣΠ-024019	3\4	27,9	240		
ΣΠ-024025	1"	35,6	210		

SAE 100 R5 ΠΑΝΙ ΕΞΩΤΕΡΙΚΑ

ΚΩΔΙΚΟΣ	διάσταση	διάσταση	bar	€	€+ΦΠΑ
	εσωτερική	εξωτερική	w.p.		
ΣΠ-050010	13\32	19,5	138		
ΣΠ-050013	1\2	23,4	121		
ΣΠ-050016	5\8	27,4	103		
ΣΠ-050022	7\8	31,4	55		
ΣΠ-050028	1" 1\8	38,1	43		
ΣΠ-050035	1" 3\8	44,5	34		
ΣΠ-050045	1"13\16	56,4	24		

SAE 100 R6 ΛΑΔΙΟΥ 1 ΛΙΝΟ

ΚΩΔΙΚΟΣ	διάσταση	διάσταση	bar	€	€+ΦΠΑ
	εσωτερική	εξωτερική	w.p.		
ΣΠ-060006	1\4	12,7	28		
ΣΠ-060008	5\16	14,3	28		
ΣΠ-060010	3\8	15,9	28		
ΣΠ-060013	1\2	19,8	28		
ΣΠ-060016	5\8	23,0	24		
ΣΠ-060019	3\4	26,9	21		
ΣΠ-060025	1"	34,4	17		

POWER STEERING 3TE για τιμόνια.

ΚΩΔΙΚΟΣ	διάσταση	διάσταση	bar	€	€+ΦΠΑ
	εσωτερική	εξωτερική	w.p.		
ΣΠ-03TE010	3\8	18,5	110		

EVOLUTION HT 150 1SN -ISO 1436-1

ΚΩΔΙΚΟΣ	διάσταση	διάσταση	bar	€	€+ΦΠΑ
	εσωτερική	εξωτερική	w.p.		
ΣΠ-130106	1\4	13,4	225		
ΣΠ-130110	3\8	17,4	180		
ΣΠ-130113	1\2	20,6	160		
ΣΠ-130116	5\8	23,7	130		
ΣΠ-130119	3\4	27,7	105		
ΣΠ-130125	1"	35,6	88		

ASPIRCARBURE M/10

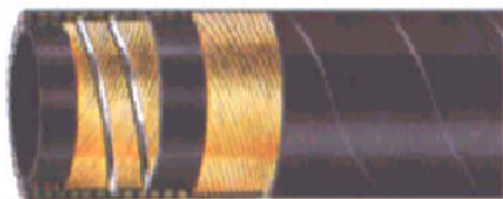

Ελαστικός σωλήνας από συνθετικό ελαστικό με ενίσχυση μιας σειράς λινής πλέξης και ελικοειδές σπирάλ. Κατάλληλη για λάδια και καύσιμα σε χαμηλή πίεση, όπου χρειάζεται μεγάλη ευλυγισία χωρίς να τσακίζει ο σωλήνας.

Θερμοκρασία λειτουργίας: -40 +125° C
Για τον αέρα max +70° C

ΚΩΔΙΚΟΣ	διάσταση	διάσταση	bar	€	€+ΦΠΑ
	εσωτερική	εξωτερική	w.p.		
ΣΒ-160016	16	26	10		
ΣΒ-160019	19	29	10		
ΣΒ-160022	22	32	10		
ΣΒ-160025	25	35	10		
ΣΒ-160030	30	40	10		
ΣΒ-160032	32	42	10		
ΣΒ-160035	35	46	10		
ΣΒ-160038	38	50	10		
ΣΒ-160040	40	52	10		
ΣΒ-160042	42	56	10		
ΣΒ-160045	45	57	10		
ΣΒ-160050	51	63	10		
ΣΒ-160056	55	67	10		
ΣΒ-160060	60	74	10		
ΣΒ-160063	63	77	10		
ΣΒ-160070	70	84	10		
ΣΒ-160076	76	90	10		
ΣΒ-160080	80	94	10		
ΣΒ-160090	90	104	10		
ΣΒ-160100	102	111	10		

ARIA STEEL ΓΕΩΤΡΥΠΑΝΩΝ (1 ΣΥΡΜΑ)



ΚΩΔΙΚΟΣ	διάσταση	διάσταση	bar	€	€+ΦΠΑ
	εσωτερική	εξωτερική	w.p.		
ΣΠ-010063	2" 1\2	80	35		
ΣΠ-010075	3"	96	35		

Ειδικός σωλήνας απόφραξης με λινά.



PIPE CLEAN 250BAR textile

ΚΩΔΙΚΟΣ	διάσταση	διάσταση	bar	€	€+ΦΠΑ
	εσωτερική	εξωτερική	w.p.		
ΣΠ-110013	1\2	25	250		
ΣΠ-110019	3\4	31	250		
ΣΠ-110025	1"	39	250		

Ελαφρύς σωλήνας, εύκαμπτος, σε κουλούρες των 100 -120μέτρων. με ρακόρ πρεσαρισμένα αρσενικό-θηλυκό.

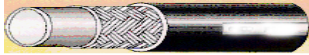

Ειδικός σωλήνας με λινά, ελαφρύς, εύκαμπτος, χωρίς να λερώνει. Κατασκευασμένος εξωτερικά από πολυουρεθάνη για Hobby πλυστικά και αποφράξεις.

ΘΕΡΜΟΠΛΑΣΤΙΚΟΣ HOBBY με λινά 160bar

ΚΩΔΙΚΟΣ	ΧΡΩΜΑ	διάσταση	διάσταση	bar	€	€+ΦΠΑ
		εσωτερική	εξωτερική	w.p.		
ΣΠ-070000	ΜΑΥΡΟ	1\4	11,50	160		

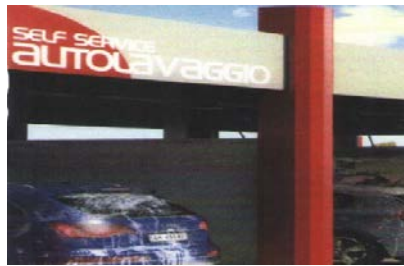

CAR WASH 250bar

με λινά

Ειδικός σωλήνας με λινά, ελαφρύς, εύκαμπτος, εξωτερικά από πολυουρεθάνη για σταθμούς αυτοεξυπηρέτησης, carwash

ΚΩΔΙΚΟΣ	ΧΡΩΜΑ	διάσταση	διάσταση	bar	€	€+ΦΠΑ
		εσωτερική	εξωτερική	w.p.		
ΣΠ-070001	ΚΟΚΚΙΝΗ	1\4	12,5	250		
ΣΠ-07M001	ΜΠΛΕ	1\4	12,5	250		
ΣΠ-07B001	ΜΑΥΡΗ	1\4	12,5	250		
ΣΠ-070002	ΜΠΛΕ	1\4	12,0	227		

HOT WATER 225 bar 1SC +155° C superservice

ΚΩΔΙΚΟΣ	ΧΡΩΜΑ	διάσταση	διάσταση	bar	€	€+ΦΠΑ
		εσωτερική	εξωτερική	w.p.		
ΣΠ-010106	ΜΑΥΡΗ	1\4	13,2	225		
ΣΠ-010206	ΜΠΛΕ	1\4	13,2	225		

HOT WATER 400 bar 2SC +155°C ζεστού νερού 2 σύρματα

ΚΩΔΙΚΟΣ	ΧΡΩΜΑ	διάσταση	διάσταση	bar	€	€+ΦΠΑ
		εσωτερική	εξωτερική	w.p.		
ΣΠ-020106	ΜΑΥΡΗ	1\4	13,4	400		
ΣΠ-020108	ΜΑΥΡΗ	5\16	15,0	400		
ΣΠ-020110	ΜΑΥΡΗ	3\8	17,4	400		

Σωλήνας εύκαμπτος, ελαφρύς. Κατάλληλος για ζεστό και κρύο νερό στα μέτριας πίεσης πλυστικά.



Σωλήνας εύκαμπτος, ελαφρύς. Κατάλληλος για ζεστό και κρύο νερό σε κάθε πλυστικό μηχάνημα.

ΣΠ-020208	ΜΠΛΕ	5\16	15,0	400		
ΣΠ-020210	ΜΠΛΕ	3\8	17,4	400		

HOT WATER 500 bar +155° C ζεστού νερού

ΚΩΔΙΚΟΣ	ΧΡΩΜΑ	διάσταση	διάσταση	bar	€	€+ΦΠΑ
		εσωτερική	εξωτερική	w.p.		
ΣΠ-025010	ΜΑΥΡΗ	3\8	17,4	500		

WB 15 WATERBLAST (ΥΔΡΟΒΟΛΩΝ)

ΚΩΔΙΚΟΣ	διάσταση	διάσταση	bar	bar	€	€+ΦΠΑ
	εσωτερική	εξωτερική	w.p.	b.p.		
ΣΠ-042010	3\8	21,4	1250	3125		
ΣΠ-042013	1\2	25,4	1100	2750		
ΣΠ-042019	3\4	31,8	1000	2500		

Συνθετικός σωλήνας για νερό και λάδι με ενίσχυση 4 ατσάλινων πλεγμάτων. Ειδικά κατασκευασμένος για σκληρή δουλειά σε υδροβολές.

Θερμοκρασία λειτουργίας: -10+70°C

Σε μήκος 15,25 ή 20 μετρων

Κατόπιν παραγγελίας

HOBBY

CARWASH

155°C 225 bar

HOT WATER 400 bar

HOT WATER 500bar

WATERBLAST 500bar



ΣΩΛΗΝΕΣ ΘΕΡΜΟΠΛΑΣΤΙΚΟΙ ΜΕ ΛΙΝΑ

JET CLEAN Θερμοπλαστικός



πορτοκαλί χρώματος, εσωτερικά από πολυεστέρα και εξωτερικά από πολυουρεθάνη. Κατάλληλος για εγκαταστάσεις υψηλής πίεσης νερού σε βιομηχανίες

ΚΩΔΙΚΟΣ	διάσταση	διάσταση	bar	€	€+ΦΠΑ
	εσωτερική	εξωτερική	w.p.		
ΣΠ-100013	1\2	22,4	280		
ΣΠ-100016	5\8	26,5	220		
ΣΠ-100019	3\4	29,8	200		
ΣΠ-100025	1"	37,3	200		

Θερμοκρασία λειτουργίας -40 +55 ° C

OL5 - OL7 SAE 100 R7 ΜΕ ΛΙΝΑ



Εσωτερικό από θερμοπλαστικό πολυεστέρα ενισχυμένο από πολυεστερικές ίνες. Κάλυμμα από πολυουρεθάνη μεγάλης αντοχής σε καιρικές συνθήκες και μικροοργανισμούς. Κατάλληλη για χρήση λαδιού και νερού. Για αέρια μπορεί να παραγγελθεί micro perforated.

Θερμοκρασία λειτουργίας -40 +100 ° C

ΚΩΔΙΚΟΣ	διάσταση	διάσταση	bar	€	€+ΦΠΑ
	εσωτερική	εξωτερική	w.p.		
ΣΠ-070018	1\8	7,5	200		
ΣΠ-070003	5\32(4mm)	8,0	200		
ΣΠ-070005	3\16	9,2	200		
OL7					
ΣΠ-070006	1\4	11,80	200		
ΣΠ-070008	5\16	14,30	190		
ΣΠ-070010	3\8	16,00	175		
ΣΠ-070013	1\2	20,30	140		

Συντελεστής Ασφαλείας 4:1

ΔΙΠΛΟΣ ΕΝΩΜΕΝΟΣ με λινά

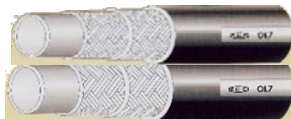

ΚΩΔΙΚΟΣ	διάσταση		bar	€	€+ΦΠΑ
	εσωτερική	εξωτερική	w.p.		
ΣΠ-070205	3/16	10X2	210		
ΣΠ-070206	1\4	11,8X2	200		
ΣΠ-070208	5\16	14,3X2	190		
ΣΠ-070210	3\8	16X2	175		
ΣΠ-070213	1\2	20,3X2	140		

OL 8



Εσωτερικό από θερμοπλαστικό πολυεστέρα ενισχυμένο από πολυεστερικές ίνες. Κάλυμμα από πολυουρεθάνη μεγάλης αντοχής σε καιρικές συνθήκες και μικροοργανισμούς. Κατάλληλη για χρήση λαδιού και νερού. Για αέρια μπορεί να παραγγελθεί micro perforated.

ΚΩΔΙΚΟΣ	διάσταση	διάσταση	bar	€	€+ΦΠΑ
	εσωτερική	εξωτερική	w.p.		
ΣΠ-080103	1\8	7,1	420		
ΣΠ-080104	5\32(4mm)	8,0	420		
ΣΠ-080106	1\4	11,80	350		
ΣΠ-080113	1\2	20,30	245		

ΔΙΠΛΟΣ ΕΝΩΜΕΝΟΣ

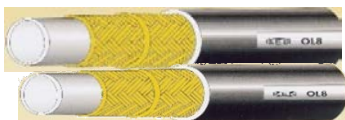

Συντελεστής Ασφαλείας 4:1

Θερμοκρασία λειτουργίας -40 +100 ° C

ΚΩΔΙΚΟΣ	διάσταση	διάσταση	bar	€	€+ΦΠΑ
	εσωτερική	εξωτερική	w.p.		
ΣΠ-088007	1\4	11,8X2	350		
ΣΠ-088009	5\16	14,3X2	325		
ΣΠ-088011	3\8	16X2	280		
ΣΠ-088013	1\2	20,3X2	245		

OL 8 M 700bar very high pressure



Εσωτερικό από θερμοπλαστικό πολυεστέρα ενισχυμένο από πολυεστερικές ίνες. Κάλυμμα από πολυουρεθάνη μεγάλης αντοχής σε καιρικές συνθήκες και μικροοργανισμούς. Κατάλληλη για χρήση λαδιού και νερού.

ΚΩΔΙΚΟΣ	διάσταση	διάσταση	bar	€	€+ΦΠΑ
	εσωτερική	εξωτερική	w.p.		
ΣΠ-077006	1\4	14,8	700		
ΣΠ-077010	3\8	18	700		

Jet Clean

OL 5-OL 7 ΛΙΝΑ

OL8

OL8M

ΣΩΛΗΝΕΣ ΘΕΡΜΟΠΛΑΣΤΙΚΟΙ ΜΕ ΣΥΡΜΑ

ΜΤΗ1

ΜΤΗ1 ΔΙΠΛΟΣ

ΜΤΗ1 (1 ΣΥΡΜΑ)



Εσωτερικό από θερμοπλαστικό πολυεστέρα ενισχυμένο από ασάλινο πλέγμα εφελκισμού. Κάλυμμα από πολυουρεθάνη μεγάλης αντοχής σε καιρικές συνθήκες και μικροοργανισμούς. Κατάλληλη για χρήση λαδιού και νερού. Για αέρια μπορεί να παραγγελθεί micro perforated.



Συντελεστής Ασφαλείας 4:1

Θερμοκρασία λειτουργίας -40 +100 ° C

ΚΩΔΙΚΟΣ	διάσταση	διάσταση	bar	€	€+ΦΠΑ
	εσωτερική	εξωτερική	w.p.		
ΣΠ-080005	3/16	10,0	325		
ΣΠ-080006	1\4	11,9	300		
ΣΠ-080008	5\16	14,0	240		
ΣΠ-080010	3\8	16,0	225		
ΣΠ-080013	1\2	19,2	190		

ΔΙΠΛΟΣ ΕΝΩΜΕΝΟΣ

ΚΩΔΙΚΟΣ	εσωτερική	εξωτερική	bar	€	€+ΦΠΑ
ΣΠ-080205	3/16	10X2	325		
ΣΠ-080206	1\4	11,9X2	300		
ΣΠ-080208	5\16	14X2	240		
ΣΠ-080210	3\8	16X2	225		
ΣΠ-080213	1\2	19,2X2	190		

ΜΤΚ Μ

ΜΤΚ Μ (FIBER+2 ΣΥΡΜΑΤΑ)



Εσωτερικό από πολυαμίδιο ενισχυμένο με 2 ασάλινα πλέγματα εφελκισμού. Κάλυμμα από πολυουρεθάνη μεγάλης αντοχής σε καιρικές συνθήκες. Κατάλληλη για χρήση λαδιού, νερού, χρωμάτων, διαλυτών. Για αέρια μπορεί να

Συντελεστής Ασφαλείας 4:1

Θερμοκρασία λειτουργίας -40 +100 ° C

ΚΩΔΙΚΟΣ	διάσταση	διάσταση	bar	€	€+ΦΠΑ
	εσωτερική	εξωτερική	w.p.		
ΣΠ-083006	1\4	14,5	800		
ΣΠ-083010	3\8	18,80	700		
ΣΠ-083013	1\2	25,2	700		

ΣΩΛΗΝΕΣ ΘΕΡΜΟΠΛΑΣΤΙΚΟΙ ΕΙΔΙΚΩΝ ΧΡΗΣΕΩΝ

ΟΛ8 NC

ΟΛ 8 NC ΜΟΝΩΤΙΚΗ



Σωλήνα καθαφορών μονωτική για την ασφάλεια του χειριστή από ηλεκτροπληξία.

ΚΩΔΙΚΟΣ	διάσταση	διάσταση	bar	€	€+ΦΠΑ
	εσωτερική	εξωτερική	w.p.		
ΣΠ-088006	1\4	11,80	350		
ΣΠ-088008	5\16	14,30	325		
ΣΠ-088010	3\8	16,00	280		

ΟΛ TEST

ΟΛ TEST MICROTUBI



Ειδική σωλήνα για μέτρηση πίεσης.



ΚΩΔΙΚΟΣ	διάσταση	διάσταση	bar	€	€+ΦΠΑ
	εσωτερική	εξωτερική	w.p.		
MT-000000	2,1	5,1	630		

ΑΤ 8S

ΑΤ8S Breathing Air



Εσωτερικό από θερμοπλαστικό πολυμερικό κατάλληλο να έρθει σε επαφή με τρόφιμα. Ειδικά σχεδιασμένο για πλήρωση φιάλων οξυγόνου και αναπνεύσιμου αέρα δυτών.

Κατόπιν παραγγελίας

ΚΩΔΙΚΟΣ	διάσταση	διάσταση	bar	€	€+ΦΠΑ
	εσωτερική	εξωτερική	w.p.		
ΣΠ-ΑΤ8S05	3/16	10,5	413		
ΣΠ-ΑΤ8S14	1\4	12,7	413		
ΣΠ-ΑΤ8S38	3\8	16,0	413		

JET POWER



ΣΠ-079003	1\8	11,2	1120		
ΣΠ-079005	3\16	11,3	800		
ΣΠ-079006	1\4	14,50	1120		
ΣΠ-079008	5\16	16,00	1000		
ΣΠ-079010	3\8	18,80	1120		

Κατόπιν παραγγελίας

TEFLON (1 ΣΥΡΜΑ)	ΚΩΔΙΚΟΣ	διάσταση	διάσταση	bar	€	€+ΦΠΑ
		εσωτερική	εξωτερική	w.p.		
	ΣΒ-180003	1/8 B.T	6,70	285		
	ΣΒ-180005	3/16	7,40	200		
	ΣΒ-180006	1/4	8,90	175		
	ΣΒ-180008	5/16	10,90	150		
	ΣΒ-180010	3/8	12,40	135		
	ΣΒ-180013	1/2 B.T	16,20	120		
	ΣΒ-180016	5/8 B.T	19,50	110		
	ΣΒ-180019	3/4 B.T	22,60	90		
	ΣΒ-180025	1" B.T	29,70	70		

Εσωτερικό από Teflon PTFE πλέγμα.
Κατασκευασμένη κυρίως για υψηλές πιέσεις λαδιού, βαφής, νερού, αέρα και ατμού.

Θερμοκρασία -60 +260° C

TEFLON (2 ΣΥΡΜΑΤΑ)	ΚΩΔΙΚΟΣ	διάσταση	διάσταση	bar	€	€+ΦΠΑ
		εσωτερική	εξωτερική	w.p.		
	ΣΒ-182006	1/4	11,20	365		
	ΣΒ-182008	5/16	13,45	300		
	ΣΒ-182010	3/8	15,05	285		
	ΣΒ-182013	1/2	18,40	250		
	ΣΒ-182016	5/8	22,00	235		
	ΣΒ-182019	3/4	25,20	200		
	ΣΒ-182025	1"	32,65	150		

Εσωτερικό από Teflon PTFE πλέγμα.
Κατασκευασμένη κυρίως για υψηλές πιέσεις λαδιού, βαφής, νερού, αέρα και ατμού.



Θερμοκρασία -60 +260° C

TEFLON Spiral εύκαμπτο	ΚΩΔΙΚΟΣ	διάσταση	διάσταση	bar	€	€+ΦΠΑ
		εσωτερική	εξωτερική	w.p.		
	ΣΒ-181013	1/2	19	110		
	ΣΒ-181016	5/8	23	80		
	ΣΒ-181019	3/4	27,5	60		
	ΣΒ-181025	1"	34,5	45		

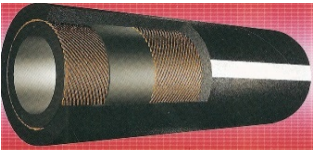
Ιδιαίτερως σε χρήσεις που η ευκαμψία και η ελαστικότητα είναι απαραίτητα.

steelvapor (ΑΤΜΟΥ) 17 bar	ΚΩΔΙΚΟΣ	διάσταση	διάσταση	bar	€	€+ΦΠΑ
		εσωτερική	εξωτερική	w.p.		
	ΣΒ-230013	1/2	25	17		
	ΣΒ-230016	5/8	28	17		
	ΣΒ-230019	3/4	32	17		
	ΣΒ-230025	1"	38	17		
	ΣΒ-230032	1"1/4	46	17		
	ΣΒ-230038	1"1/2	54	17		
	ΣΒ-230050	2"	68	17		

Κατασκευασμένη από EPDM με συμπίεση ενίσχυση για μεταφορά ατμού.

ΘΕΥΓΟΝΟΥ - ΑΣΕΤΥΛΙΝΗΣ	ΚΩΔΙΚΟΣ	διάσταση	διάσταση	bar	€	€+ΦΠΑ
		εσωτερική	εξωτερική	w.p.		
ΘΕΥΓΟΝΟΥ ΣΕ ΜΠΛΕ ΧΡΩΜΑ						
	ΣΒ144108	8	15	20		
	ΑΣΕΤΥΛΙΝΗΣ ΣΕ ΚΟΚΚΙΝΟ ΧΡΩΜΑ					
	ΣΒ144308	8	15	20		
	ΘΕΥΓΟΝΟΥ- ΑΣΕΤΥΛΙΝΗΣ ΔΙΠΛΟΣ					
	ΣΒ-144208	8mm	15	20		

FLEX

FLEX (ΠΕΤΡΕΛΑΙΟΥ) ΙΤΑΛΙΑΣ	ΚΩΔΙΚΟΣ	διάσταση	διάσταση	bar	€	€+ΦΠΑ
		εσωτερική	εξωτερική	w.p.		
 <p>Θερμοκρασία λειτουργίας -40 +80° C</p> <p>Σωλήνας από συνθετικό ελαστικό με εξωτερική ενίσχυση από γαλβανισμένο πλέγμα. Χρήση για λάδι, νερό και αέρα.</p>	ΣΒ-100004	3\16	10	15		
	ΣΒ-100005	1\4	11	25		
	ΣΒ-100007	5\16	13	25		
	ΣΒ-100009	3\8	15	25		
	ΣΒ-100014	1\2	19	20		
	ΣΒ-100017	5\8	21	10		
	ΣΒ-100019	3\4	24	10		

BENZINΗΣ

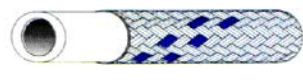
FLEX (ΠΕΤΡΕΛΑΙΟΥ) ΓΕΡΜΑΝΙΑΣ	ΚΩΔΙΚΟΣ	διάσταση	διάσταση	bar	€	€+ΦΠΑ
		εσωτερική	εξωτερική	w.p.		
 <p>Θερμοκρασία λειτουργίας -40 +80° C</p> <p>Σωλήνας από συνθετικό ελαστικό με εξωτερική ενίσχυση από γαλβανισμένο πλέγμα. Χρήση για λάδι, πετρέλαιο, νερό και αέρα.</p>	ΣΒ-110004	4,5	9,5	15		
	ΣΒ-110005	5,5	10,5	15		
	ΣΒ-110007	7,5	12,5	15		
	ΣΒ-110009	9	15	15		
	ΣΒ-110011	11	17,5	12		

SCHMITTER GERMANY



ΣΩΛΗΝ ΒΕΝΖΙΝΗΣ ΠΑΝΙ για SUPER BENZINA- DIESEL	ΚΩΔΙΚΟΣ	διάσταση	διάσταση	bar	€	€+ΦΠΑ
		εσωτερική	εξωτερική	w.p.		
 <p>SCHMITTER GERMANY</p>	ΣΒ-220003	3mm	7	10		
	ΣΒ-220004	4,5mm	9,5	10		
	ΣΒ-220005	5,5mm	10,5	10		
	ΣΒ-220006	7mm	12	10		
	ΣΒ-220008	7,5mm	12,5	10		
	ΣΒ-220010	9mm	15	10		

ΚΑΥΣΙΜΩΝ

ΣΩΛΗΝ ΑΜΟΛΥΒΔΗΣ CARBO POMP 10	ΚΩΔΙΚΟΣ	διάσταση	διάσταση	bar	€	€+ΦΠΑ
		εσωτερική	εξωτερική	w.p.		
 <p>Μαύρος, λείος . Για αυτοκίνητα και βιομηχανικά οχήματα που χρησιμοποιούν αμόλυβδη βενζίνη ecodiesel. Θραύση: 30 bar</p> <p>Θερμοκρασία λειτουργίας -20 +120° C</p>	ΣΒ-222305	5mm	12	10		
	ΣΒ-222306	7mm	13	10		
	ΣΒ-222308	8mm	15	10		
	ΣΒ-222310	10mm	17	10		
	ΣΒ-222313	13mm	20	10		

ΚΑΥΣΙΜΩΝ-ΛΑΔΙΟΥ ΛΕΙΟΣ Carburante 20 bar	ΚΩΔΙΚΟΣ	διάσταση	διάσταση	bar	€	€+ΦΠΑ
		εσωτερική	εξωτερική	w.p.		
 <p>Για λάδι, super βενζίνη, πετρέλαιο. Όχι</p>	ΣΒ-221105	5	11	20		
	ΣΒ-221106	6	12	20		
	ΣΒ-221108	8	14	20		
	ΣΒ-221110	10	17	20		

ΚΑΥΣΙΜΩΝ ΒΥΤΙΩΝ 10bar Για βυτία μεταφοράς πετρελαίου.	ΚΩΔΙΚΟΣ	διάσταση	διάσταση	bar	€	€+ΦΠΑ
		εσωτερική	εξωτερική	w.p.		
	ΣΒ-190125	25	35	10		
	ΣΒ-190132	32	42	10		
	ΣΒ-190138	38	48	10		

FREON J 51B GALAXY BARRIER (2 ΛΙΝΑ)	ΚΩΔΙΚΟΣ	διάσταση	διάσταση	bar	€	€+ΦΠΑ
		εσωτερική	εξωτερική	w.p.		
 Freon R12 R134a	ΣΒ-200008	5\16	19	35		
	ΣΒ-200010	13\32	23	35		
	ΣΒ-200013	1\2	25,5	35		
	ΣΒ-200016	5\8	28	35		
FROST REDUSED U.S.A λινά λεπτή εξωτερικά						
 J3062typeC R-134A AND R-1234YF	ΣΒ-200108	5\16	14,7	27		
	ΣΒ-200110	13\32	17,3	27		
	ΣΒ-200113	1\2	19,4	27		
	ΣΒ-200116	5\8	23,6	20		
FREON SAE J 2064 typeb class 1 (1 ΣΥΡΜΑ)						
 Freon R12 R134a	ΚΩΔΙΚΟΣ	διάσταση		bar	€	€+ΦΠΑ
		εσωτερική		w.p.		
	ΣΒ-200208	5\16		35		
	ΣΒ-200210	13\32		35		
	ΣΒ-200213	1\2		35		
	ΣΒ-200216	5\8		35		
	ΣΒ-200022	7\8		35		
ΣΒ-200028	1"1\8		35			

ΖΕΣΤΟΥ ΝΕΡΟΥ ΑΥΤΟΚΙΝΗΤΩΝ RADIATOR HOSE 3- 5 bar	ΚΩΔΙΚΟΣ	διάσταση	διάσταση	bar	€	€+ΦΠΑ
		εσωτερική	εξωτερική	w.p.		
 <p>Σωλήνας από μαύρο ελαστικό EPDM ενισχυμένος από συνθετικά λινά υψηλής αντοχής, κατάλληλος για καλοριφέρ αυτοκινήτων. Μεγάλη αντοχή σε διάβρωση, όζον, καιρικές συνθήκες και θερμοκρασίες.</p> <p>Διάμετροι 18mm-38mm: 1-40m 40mm-102mm: 1m</p>	ΣΒ-290018	18	24	3-5		
	ΣΒ-290020	20	26	3-5		
	ΣΒ-290022	22	28	3-5		
	ΣΒ-290025	25	32	3-5		
	ΣΒ-290028	28	35	3-5		
	ΣΒ-290030	30	38	3-5		
	ΣΒ-290032	32	40	3-5		
	ΣΒ-290035	35	43	3-5		
	ΣΒ-290038	38	46	3-5		
	ΣΒ-290040	40	48	3-5		
	ΣΒ-290042	42	51	3-5		
	ΣΒ-290045	45	54	3-5		
	ΣΒ-290051	51	60	3-5		
	ΣΒ-290055	55	65	3-5		
	ΣΒ-290060	60	70	3-5		

Θερμοκρασία -40° +120° C

Συντελεστής ασφαλείας 3:1

ΖΕΣΤΟΥ ΝΕΡΟΥ ΒΙΟΜΗΧΑΝΙΑΣ CALOR M /10 bar	ΚΩΔΙΚΟΣ	διάσταση	διάσταση	bar	€	€+ΦΠΑ
		εσωτερική	εξωτερική	w.p.		
 -40° +120° C	ΣΒ-145013	13	23	10		
	ΣΒ-145016	16	26	10		
	ΣΒ-145019	19	29	10		
	ΣΒ-145025	25	35	10		

Μαύρο ελαστικό EPDM ενισχυμένος από συνθετικά λινά υψηλής αντοχής. Κατάλληλος για τροφοδοσία

Μήκη: ρολλά 40 μέτρων max

FREON

ΚΟΛΠΑ ΑΥΤΟΚΙΝΗΤΩΝ

ΖΕΣΤΟΥ ΝΕΡΟΥ



ΣΙΛΙΚΟΝΗΣ ΙΣΙΑ 1 Μέτρου					ΑΜΒΛΕΙΕΣ 45° μήκος 152mm					ΓΩΝΙΕΣ 90° μήκος 152mm				
ΚΩΔΙΚΟΣ	mm	ΛΙΝΑ	€	€ +ΦΠΑ	ΚΩΔΙΚΟΣ	mm	ΛΙΝΑ	€	€ +ΦΠΑ	ΚΩΔΙΚΟΣ	mm	ΛΙΝΑ	€	€ +ΦΠΑ
ΣΒ-360006	6,5	3			ΣΒ-380006	6,5	3			ΣΒ-370006	6,5	3		
ΣΒ-360008	8	3			ΣΒ-380008	8	3			ΣΒ-370008	8	3		
ΣΒ-360010	9,5	3			ΣΒ-380010	9,5	3			ΣΒ-370010	9,5	3		
ΣΒ-360011	11	3			ΣΒ-380011	11	3			ΣΒ-370011	11	3		
ΣΒ-360013	13	3			ΣΒ-380013	13	3			ΣΒ-370013	13	3		
ΣΒ-360016	16	3			ΣΒ-380016	16	3			ΣΒ-370016	16	3		
ΣΒ-360019	19	3			ΣΒ-380018	19	3			ΣΒ-370019	19	3		
ΣΒ-360022	22	3			ΣΒ-380022	22	3			ΣΒ-370022	22	3		
ΣΒ-360025	25	3			ΣΒ-380025	25	3			ΣΒ-370025	25	3		
ΣΒ-360028	28	3			ΣΒ-380028	28	3			ΣΒ-370028	28	3		
ΣΒ-360030	30	3			ΣΒ-380030	30	3			ΣΒ-370030	30	3		
ΣΒ-360035	35	3			ΣΒ-380035	35	3			ΣΒ-370035	35	3		
ΣΒ-360038	38	3			ΣΒ-380038	38	3			ΣΒ-370038	38	3		
ΣΒ-360040	40	3			ΣΒ-380040	40	3			ΣΒ-370040	40	3		
ΣΒ-360045	45	3			ΣΒ-380045	45	3			ΣΒ-370045	45	3		
ΣΒ-360050	51	4			ΣΒ-380050	50,8	4			ΣΒ-370050	51	4		
ΣΒ-360055	55	4			ΣΒ-380055	55	4			ΣΒ-370055	55	4		
ΣΒ-360060	60	4			ΣΒ-380060	61	4			ΣΒ-370060	61	4		
ΣΒ-360065	65	4			ΣΒ-380065	65	4			ΣΒ-370065	65	4		
ΣΒ-360070	70	4			ΣΒ-380070	70	4			ΣΒ-370070	70	4		
ΣΒ-360075	75	5			ΣΒ-380075	75	5			ΣΒ-370075	75	5		
ΣΒ-360080	80	5			ΣΒ-380080	80	5			ΣΒ-370080	80	5		
ΣΒ-360090	90	5			ΣΒ-380090	90	5			ΣΒ-370090	90	5		
ΣΒ-360100	102	5			ΣΒ-380100	102	5			ΣΒ-370100	102	5		



ΣΥΣΤΟΛΙΚΑ ΜΗΚΟΥΣ 127mm

ΚΩΔΙΚΟΣ	Διάμετρος	€	€ +ΦΠΑ
ΣΒ-363525	35 25		
ΣΒ-363825	38 25		
ΣΒ-364235	41 35		
ΣΒ-364532	45 32		
ΣΒ-364538	45 38		
ΣΒ-365138	51 38		
ΣΒ-365145	51 45		
ΣΒ-365451	54 51		
ΣΒ-366051	60 51		
ΣΒ-366054	60 54		
ΣΒ-367051	70 51		
ΣΒ-367060	70 60		



ΙΣΙΑ HUMP HOSE L102mm

ΚΩΔΙΚΟΣ	mm	παχο	€	€ +ΦΠΑ
ΣΒ-400045	45	4,5		
ΣΒ-400051	51	5		
ΣΒ-400058	58	5		
ΣΒ-400060	60	5		
ΣΒ-400063	63	5		
ΣΒ-400070	70	5		
ΣΒ-400076	76	5,5		
ΣΒ-400080	80	5,5		
ΣΒ-400090	90	5,5		
ΣΒ-400102	102	5,5		

ΣΥΣΤΟΛΙΚΕΣ ΓΩΝΙΕΣ 90°

ΣΒ-372216	22	16		
ΣΒ-372218	22	18		
ΣΒ-372516	25	16		
ΣΒ-372519	25	19		
ΣΒ-372822	28	22		
ΣΒ-373225	32	25		
ΣΒ-373525	35	25		
ΣΒ-373532	35	32		
ΣΒ-373832	38	32		
ΣΒ-373835	38	35		
ΣΒ-374532	45	32		
ΣΒ-374538	45	38		
ΣΒ-375138	51	38		
ΣΒ-375145	51	45		
ΣΒ-375751	57	51		
ΣΒ-376051	60	51		
ΣΒ-376057	60	57		
ΣΒ-376345	63	45		
ΣΒ-376351	63	51		
ΣΒ-376357	63	57		
ΣΒ-377060	70	60		



ΣΙΛΙΚΟΝΗΣ ΚΑΛΟΡΙΦΕΡ -60°+200° C



Σωλήνας σιλικόνης ειδικός για ψυγεία αυτοκινήτων, φορτηγών, γεννητριών, μεταφοράς υγρών ψυγείου και αντιψυκτικών SAEJ20R1 classA με λινή πολυεστερική ενίσχυση

ΣΩΛΗΝΑΣ ΥΠΟΠΙΕΣΗΣ ΣΙΛΙΚΟΝΗΣ

ΚΩΔΙΚΟΣ	Διάμετρος	παχος	€	€ +ΦΠΑ
ΣΒ-390003	3mm	2mm		
ΣΒ-390004	4mm	2mm		
ΣΒ-390005	5mm	2,5mm		
ΣΒ-390006	6mm	2,5mm		
ΣΒ-390008	8mm	3mm		

ΚΩΔΙΚΟΣ	Διάμετρος	παχος	bar W.P.	€	€ +ΦΠΑ
ΣΒ-410006	6	4	5,5		
ΣΒ-410008	8	4	5,5		
ΣΒ-410010	10	4	5,5		
ΣΒ-410013	13	4	5,5		
ΣΒ-410016	16	4	5,5		
ΣΒ-410019	19	4	4,5		
ΣΒ-410022	22	5	4		
ΣΒ-410025	25	5	4		
ΣΒ-410028	28	5,5	4		
ΣΒ-410030	30	5,5	4		
ΣΒ-410032	32	5,5	4		

ΣΩΛΗΝΕΣ ΘΕΡΜΟΠΛΑΣΤΙΚΟΙ ΜΕ ΛΙΝΑ CIDAT italy

SAE 100 R7 ΜΕ ΛΙΝΑ



Εσωτερικό από θερμοπλαστικό πολυεστέρα ενισχυμένο από πολυεστερικές ίνες. Κάλυμμα από πολυουρεθάνη μεγάλης αντοχής σε καιρικές συνθήκες και μικροοργανισμούς.

Κατάλληλη για χρήση λαδιού και νερού.

Για αέρια μπορεί να παραγγελθεί micro perforated

Συντελεστής Ασφαλείας 4:1

Θερμοκρασία λειτουργίας -40 +100 ° C

SAE 100 R7 ΜΕ ΛΙΝΑ ΔΙΠΛΟΣ



ΚΩΔΙΚΟΣ	διάσταση		bar w.p.	€	€+ΦΠΑ
	εσωτερική	εξωτερική			
ΣΠ-770005	3/16	10,1	210		
ΣΠ-770006	1/4	12,2	200		
ΣΠ-770008	5/16	14,3	190		
ΣΠ-770010	3/8	15,9	160		
ΣΠ-770013	1/2	20,3	140		

ΚΩΔΙΚΟΣ	διάσταση		bar w.p.	€	€+ΦΠΑ
	εσωτερική	εξωτερική			
ΣΠ-770205	3/16	10,1	210		
ΣΠ-770206	1/4	12,2	200		
ΣΠ-770208	5/16	14,3	190		
ΣΠ-770210	3/8	15,9	160		
ΣΠ-770213	1/2	20,3	140		

ΣΩΛΗΝΕΣ ΘΕΡΜΟΠΛΑΣΤΙΚΟΙ ΜΕ ΣΥΡΜΑ CIDAT italy

METAL 1 (1 ΣΥΡΜΑ)



ΚΩΔΙΚΟΣ	διάσταση		bar w.p.	€	€+ΦΠΑ
	εσωτερική	εξωτερική			
ΣΠ-780005	3/16	10,1	360		
ΣΠ-780006	1/4	12,3	310		
ΣΠ-780008	5/16	14,0	250		
ΣΠ-780010	3/8	16,0	225		
ΣΠ-780013	1/2	19,2	185		

METAL 1 (1 ΣΥΡΜΑ) ΔΙΠΛΟΣ

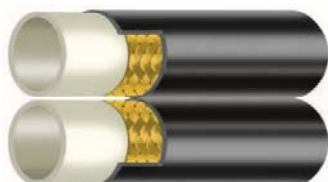

ΚΩΔΙΚΟΣ	διάσταση		bar w.p.	€	€+ΦΠΑ
	εσωτερική	εξωτερική			
ΣΠ-780205	3/16	9,6	360		
ΣΠ-780206	1/4	11,9	310		
ΣΠ-780208	5/16	14,0	250		
ΣΠ-780210	3/8	16,6	225		
ΣΠ-780213	1/2	19,2	185		

ΑΕΡΟΣ 20 bar THOR ΒΑΡΕΩΣ ΤΥΠΟΥ

Σωλήνας για αέρα και νερό από μαύρο φυσικό & συνθετικό ελαστικό, λείος εξωτερικά, με ενίσχυση από λινά αντοχής.

ΚΩΔΙΚΟΣ	διάσταση	διάσταση	bar	€	€+ΦΠΑ
	εσωτερική	εξωτερική	w.p.		
ΣΒ-142206	6	14	20		
ΣΒ-142208	8	17	20		
ΣΒ-142210	10	19	20		
ΣΒ-142213	13	23	20		
ΣΒ-142216	16	26	20		
ΣΒ-142219	19	30	20		
ΣΒ-142225	25	36	20		

AIRcompressor M/20 bar Βαρέως τύπου για αερόσφυρες

ΚΩΔΙΚΟΣ	διάσταση	διάσταση	bar	€	€+ΦΠΑ
	εσωτερική	εξωτερική	w.p.		
ΣΒ-142319	19	32	20		
ΣΒ-142132	32	44	20		
ΣΒ-142138	38	50	20		
ΣΒ-142150	51	65	20		

Συντελεστής ασφαλείας 3:1

Θερμοκρασία: -30° +70° C

Μήκος κουλούρας 40 μετρων

PRESSCORD P.U. ΑΕΡΟΕΓΓΛΕΙΩΝ 20bar

ΚΩΔΙΚΟΣ	διάσταση	διάσταση	bar	€	€+ΦΠΑ
	εσωτερική	εξωτερική	w.p.		
ΣΒ-130008	8	12	20		
ΣΒ-130010	10	15	20		

Σωλήνα για χρήση σε αέρα, νερό, ελαφριά και εύκαμπτη.

ΨΕΚΑΣΜΟΥ 40 bar PVC

Σε γεωργικές εφαρμογές ψεκασμού αέρα, νερού, φαρμάκων, εντομοκτόνων κ.λπ.

ΚΩΔΙΚΟΣ	διάσταση	διάσταση	bar	€	€+ΦΠΑ
	εσωτερική	εξωτερική	w.p.		
ΣΒ-144008	8mm	14	40		
ΣΒ-144010	10mm	16	40		
ΣΒ-144013	13mm	22	40		

Συντελεστής ασφαλείας 2,5:1

Θερμοκρασία -5° +60° C

STEELFLEX

Μη τοξική. Σωλήνας PVC διαφανής με ελικοειδές σπирάλ, κατάλληλος για αναρρόφηση και απόδοση υγρών, τροφίμων και χημικών.

ΚΩΔΙΚΟΣ	διάσταση	διάσταση	bar	€	€+ΦΠΑ
	εσωτερική	εξωτερική	w.p.		
ΣΒ-210012	12	18	7		
ΣΒ-210014	14	20	6		
ΣΒ-210016	16	22	6		
ΣΒ-210018	18	24	6		
ΣΒ-210020	20	28	5		
ΣΒ-210022	22	30	5		
ΣΒ-210025	25	33	5		
ΣΒ-210030	30	38	4,5		
ΣΒ-210032	32	40	4		
ΣΒ-210035	35	45	4		
ΣΒ-210038	38	48	4		
ΣΒ-210040	40	50	3		
ΣΒ-210045	45	55	3		
ΣΒ-210050	50	60	3		
ΣΒ-210060	60	70	2,5		

Συντελεστής ασφαλείας 3:1

Θερμοκρασία -5° +60° C

**ΚΟΦΤΗΣ ΠΛΑΣΤΙΚΟΣΩΛΗΝΩΝ ΜΕΤΑΛΙΚΟΣ**

ΣΒ-110000	ΜΕΤΑΛΙΚΟΣ 2-12mm		
ΣΒ-110001	ΜΕΤΑΛΙΚΟΣ 2-28mm		
ΣΒ-120000	ΠΛΑΣΤΙΚΟΣ 2-20mm		

ΛΑΜΑΚΙΑ ΑΝΤΑΛΛΑΚΤΙΚΑ

ΣΒ-110003	ΜΕΤΑΛΙΚΟΥ 2-12mm		
ΣΒ-110002	ΜΕΤΑΛΙΚΟΥ 2-28mm		
ΣΒ-120001	ΠΛΑΣΤΙΚΟΥ 2-20mm		



ΠΟΛΥΑΜΙΔΙΟ ΜΑΥΡΟ DIN 74 324 ΦΡΕΝΩΝ

ΚΩΔΙΚΟΣ	διάσταση	διάσταση	bar	€	€+ΦΠΑ
	εξωτερική	εσωτερική	w.p.		
ΣΒ-110402	4	2	24		
ΣΒ-110403	4	2,7			
ΣΒ-110503	5	3	25		
ΣΒ-110603	6	3	33		
ΣΒ-110604	6	4	16		
ΣΒ-110705	7	5	16,5		
ΣΒ-110805	8	5	48		
ΣΒ-110806	8	6	11		
ΣΒ-110906	9	6	20		
ΣΒ-111077	10	7	17,5		
ΣΒ-111007	10	7,5	14		
ΣΒ-111008	10	8	11		
ΣΒ-111109	11	8	15,5		
ΣΒ-111209	12	9	14		
ΣΒ-111410	14	10	17		
ΣΒ-111512	15	12	11		
ΣΒ-111612	16	12	14		
ΣΒ-111814	18	14	12,5		
ΣΒ-112003	1\8	2	17,5		
ΣΒ-112005	3\16	3	21		
ΣΒ-112006	1\4	4,3	21		
ΣΒ-112010	3\8	6,98	16		
ΣΒ-112013	1\2	9,53	14		

Σωλήνα Πολυαμιδίου σε **μαύρο** χρώμα κατάλληλη για αερόφρενα οχημάτων. Η πίεση λειτουργίας έχει μετρηθεί σε 23°C.

Συντελεστής ασφαλείας 4:1
Θερμοκρασία -40° +80° C



ΣΩΛΗΝ PA12 NSR 90bar ΑΥΤΟΛΙΠΑΝΣΗΣ - ΥΔΡΟΝΕΦΩΣΗΣ

ΚΩΔΙΚΟΣ	ΔΙΑΣΤΑΣΗ	bar	€	+ΦΠΑ
MP-110402	4X2	91		
MP-110603	6X3	93		
MΦ-010006	1\4(6,35x3)	95		
MΦ-010010	3\8 (9,5x5)	87		

ΠΟΛΥΑΜΙΔΙΟ PA6 NY6 Σκληρή

ΚΩΔΙΚΟΣ	διάσταση	διάσταση	bar	€	€+ΦΠΑ
	εξωτερική	εσωτερική	w.p.		
ΣΒ-122006	6	4	50		
ΣΒ-122008	8	6	30		
ΣΒ-122010	10	8	30		
ΣΒ-122012	12	10	25		



ΠΟΛΥΕΘΥΛΕΝΙΟΥ Ρ.Ε. Μαλακή

ΚΩΔΙΚΟΣ	διάσταση	διάσταση	bar	€	€+ΦΠΑ
	εξωτερική	εσωτερική	w.p.		
ΣΒ-120006	6	4	10		
ΣΒ-120008	8	6	7.5		
ΣΒ-120010	10	8	5,5		
ΣΒ-120012	12	10	5		



ΠΟΛΥΟΥΡΕΘΑΝΗΣ Ρ.Υ. SH98

ΚΩΔΙΚΟΣ	διάσταση	διάσταση	bar	€	€+ΦΠΑ
	εξωτερική	εσωτερική	w.p.		
ΣΒ-121004	4	2	10		
ΣΒ-121006	6	4	10		
ΣΒ-121007	8	5,5	9		
ΣΒ-121008	8	6	7		
ΣΒ-121075	10	7,5	6,5		
ΣΒ-121010	10	8	5,5		
ΣΒ-121012	12	9	6		

Spiral H.T.R. 15m



ΧΡΩΜΑΤΑ: ΠΟΡΤΟΚΑΛΙ & ΜΠΛΕ

ΚΩΔΙΚΟΣ	ΔΙΑΣΤΑΣΗ	ΜΗΚΟΣ	ΥΛΙΚΟ	€	€ + ΦΠΑ
PA-013412	6 X 4	L 15	HTR		
PA-013413	8 X 6	L 15	HTR		
PA-013414	10 X 8	L 15	HTR		

Spiral H.T.R. 30m



ΧΡΩΜΑΤΑ: ΠΟΡΤΟΚΑΛΙ & ΜΠΛΕ

ΚΩΔΙΚΟΣ	ΔΙΑΣΤΑΣΗ	ΜΗΚΟΣ	ΥΛΙΚΟ	€	€ + ΦΠΑ
PA-013401	6 X 4	L 30	HTR		
PA-013402	8 X 6	L 30	HTR		
PA-013403	10 X 8	L 30	HTR		
PA-013404	12X10	L 30	HTR		

Spiral HTR 5 μ. ίσιες άκρες



ΚΩΔΙΚΟΣ	ΔΙΑΣΤΑΣΗ	ΜΗΚΟΣ	ΥΛΙΚΟ	€	€+ΦΠΑ
PA-013410	6X4	L 5	HTR		
PA-013411	8X6	L 5	HTR		

ΠΟΡΤΟΚΑΛΙ, ΜΠΛΕ, ΜΑΥΡΟ

ΣΠΙΡΑΛ ΠΟΛΥΟΥΡΕΘΑΝΗΣ P.U.98

ίσιες άκρες

ΚΩΔΙΚΟΣ	ΔΙΑΣΤΑΣΗ	ΜΗΚΟΣ	ΥΛΙΚΟ	€	€ + ΦΠΑ
PA-013409	6X4	L 5	P. U.		

ΧΡΩΜΑΤΑ: ΚΙΤΡΙΝΟ, ΜΠΛΕ, ΜΑΥΡΟ

Μικρή διάμετρος σπείρας, πολύ μαλακό.



ΣΠΙΡΑΛ P.U98 ΙΣΙΕΣ ΑΚΡΕΣ ΧΩΡΙΣ ΡΑΚΟΡ

ΚΩΔΙΚΟΣ	ΠΕΡΙΓΡΑΦΗ	€	€+ΦΠΑ
PA-013430	P.U 98 8X5 L10m 17bar		
PA-013431	P.U 98 8X5 L15m 17bar		
PA-013432	P.U 98 10X6,5 L10m 13bar		
PA-013433	P.U 98 10X6,5 L15m 13bar		

ΣΠΙΡΑΛ ΙΣΙΕΣ ΑΚΡΕΣ ΜΕ ΡΑΚΟΡ A-A 1/4

ΚΩΔΙΚΟΣ	ΠΕΡΙΓΡΑΦΗ	€	€+ΦΠΑ
PA-013407	P.U 98 8X5 L7,5m 17bar A-A1/4		

Βαρέως τύπου για αέρα-νερό-απορρυπαντικά

σε πλυντήρια, βουλακανιζατέρ κ.λ.π

ΣΠΙΡΑΛ ΠΡΟΣΤΑΣΙΑΣ ΠΛΑΣΤΙΚΟ



Από πολυεθυλένιο, προστατεύει και ενώνει πολλές σωλήνες. Ανθεκτικό σε γράσσο, λάδι, καιρικές συνθήκες.

ΚΩΔΙΚΟΣ	διάσταση	διάσταση	κουτί	€/m	€+ΦΠΑ
	εσωτερική	εξωτερική	max		
ΣΒ-280008	8	12	50μ		
ΣΒ-280012	12	16	50μ		
ΣΒ-280016	16	20	50μ		
ΣΒ-280020	20	25	50μ		
ΣΒ-280027	27	32	50μ		
ΣΒ-280036	36	40	50μ		
ΣΒ-280044	44	50	50μ		
ΣΒ-280056	56	63	20μ		
ΣΒ-280067	67	75	20μ		
ΣΒ-280080	80	90	20μ		
ΣΒ-280100	100	110	12μ		

ΤΑΙΝΙΑ ΠΡΟΣΤΑΣΙΑΣ ΠΟΛΥΕΣΤΕΡΙΚΗ

ΚΩΔΙΚΟΣ	πλάτος mm	εσωτερικό	max m.	€/m	€ + ΦΠΑ
ΣΒ-350035	35	20	100μ		
ΣΒ-350040	40	22	100μ		
ΣΒ-350045	45	25	100μ		
ΣΒ-350050	50	28	100μ		
ΣΒ-350055	55	32	100μ		
ΣΒ-350060	60	35	100μ		
ΣΒ-350065	65	38	100μ		
ΣΒ-350080	80	45	100μ		
ΣΒ-350090	90	50	100μ		
ΣΒ-350120	120	70	100μ		
ΣΒ-350150	150	90	100μ		



ΠΛΕΓΜΑ INOX AISI 304 (ΚΑΛΤΣΑ)

ΚΩΔΙΚΟΣ	εσωτερικό	εξωτερικό	σωλήν	€/m	€ + ΦΠΑ
ΣΒ-240019	32,2	33,5	3/4		
ΣΒ-240025	41,1	42,8	1"		
ΣΒ-240032	49,8	51,2	1"1/4		

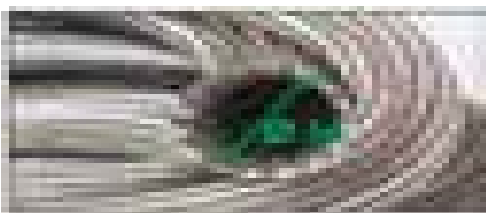



Επιλογή της εταιρείας μας από τους καλύτερους οίκους εξωτερικού με στόχο την άριστη ποιότητα για την σωστή εφαρμογή στο πρεσσάρισμα και την σωστή στεγανωποίηση. Όλα τα ρακόρ είναι θερμικώς επεξεργασμένα (ξεπτρωμένα) και ελεγμένα σύμφωνα με τις διεθνείς προδιαγραφές.



QUALITA' CERTIFICATA

IONet
THE INTERNATIONAL CERTIFICATION NETWORK
CERTIFICATE

RINA
www.rina.org
CERTIFICATO N. 90/94/S
CERTIFICATE No. 90/94/S
SI CERTIFICA CHE IL SISTEMA DI GESTIONE PER LA QUALITÀ DI
IT IS HEREBY CERTIFIED THAT THE QUALITY MANAGEMENT SYSTEM OF
STRADA BRANI
CAST SPA
STRADA BRANDIZZO ADE
NELLE SEGUENTI UNITÀ

CERTIFICATO DI OMOLOGAZIONE DI TIPO
N. MAC/63702A/TO/02
Si certifica che il seguente prodotto soddisfa le prescrizioni delle norme RINA per l'omologazione di tipo.
Raccordi per tubi
Ad asello tagliente DIN 2353
CAST SPA
STRADA BRANDIZZO 404-408 BIS
10092 BRANO (TO)

DIN-DVGW
Zertifikat über ein DIN-DVGW Prüfzeichen
certificate for a DIN-DVGW test mark
Anwendungsbereich
field of application
Zertifikatinhaber
owner of certificate
Vertreiber
distributor
Produktart
product category
Produktbezeichnung
product description
Modell
model
Bestimmungsland
country of destination
Prüfberichte
test reports
Prüfgrundlagen
basis of type examination
Abkündigung / AZ
date of expiry / file no.
18.02.2004
DVGW-Zertifizierungsstelle
DIN-DEUTSCHE VEREINIGUNG
DIN-GERMAN ASSOCIATION
DVGW certificate Reg. - entry
DIN-DEUTSCHE VEREINIGUNG
DIN-GERMAN ASSOCIATION

DET NORSKE VERITAS
TYPE APPROVAL CERTIFICATE
CERTIFICATE NO. P-11623
This Certificate consists of 4 pages
This is to certify that the
The couplings are
Air, Steel
Type:
L-Series
S-Series
Please send date
Elevik, 2004-02-18
for DET NORSKE VERITAS
John Olav Nilsen
Head of Section

DET NORSKE VERITAS
TYPE APPROVAL CERTIFICATE
CERTIFICATE NO. P-11624
This is to certify that the
Pipe Couplings, Flared
SAE J 514

FOR A CONSTANT IMPROVEMENT



ΘΗΛΥΚΑ B.S.P.



ΓΩΝΙΕΣ 90° B.S.P

ΚΩΔΙΚΟΣ	ΣΠΕΙΡΩΜΑ	ΟΥΡΑ	ΣΚΕΤΑ	ΚΟΜΠΛΕ	+ ΦΠΑ
ΡΠ-100303	1/8	1/8			
ΡΠ-100305	1/8	3/16			
ΡΠ-100605	1/4				
ΡΠ-100306	1/8	1/4			
ΡΠ-100606	1/4				
ΡΠ-101006	3/8				
ΡΠ-101306	1/2				
ΡΠ-100608	1/4	5/16			
ΡΠ-101008	3/8				
ΡΠ-101308	1/2				
ΡΠ-100610	1/4	3/8			
ΡΠ-101010	3/8				
ΡΠ-101310	1/2				
ΡΠ-101013	3/8	1/2			
ΡΠ-101313	1/2				
ΡΠ-101613	5/8				
ΡΠ-101912	3/4				
ΡΠ-101316	1/2*	5/8			
ΡΠ-101616	5/8				
ΡΠ-101916	3/4				
ΡΠ-102516	1"				
ΡΠ-101319	1/2*	3/4			
ΡΠ-101919	3/4				
ΡΠ-102519	1"				
ΡΠ-101925	3/4*	1"4SH			
ΡΠ-102525	1"				
ΡΠ-103225	1"1/4				
ΡΠ-103232	1" 1/4	1" 1/4			
ΡΠ-103832	1" 1/2				
ΡΠ-103838	1" 1/2	1" 1/2			
ΡΠ-105038	2" *				
ΡΠ-105050	2"	2"			
ΡΠ-106363	2"½	2"½			
ΡΠ-107575	3"	3"			

ΚΩΔΙΚΟΣ	ΣΠΕΙΡΩΜΑ	ΟΥΡΑ	ΣΚΕΤΑ	ΚΟΜΠΛΕ	+ ΦΠΑ
ΡΠ-110303	1/8	1/8			
ΡΠ-110305	1/8	3/16			
ΡΠ-110605	1/4				
ΡΠ-110306	1/8	1/4			
ΡΠ-110606	1/4				
ΡΠ-111006	3/8				
ΡΠ-111306	1/2				
ΡΠ-110608	1/4	5/16			
ΡΠ-111008	3/8				
ΡΠ-111308	1/2				
ΡΠ-110610	1/4	3/8			
ΡΠ-111010	3/8				
ΡΠ-111310	1/2				
ΡΠ-111013	3/8	1/2			
ΡΠ-111313	1/2				
ΡΠ-111613	5/8				
ΡΠ-111913	3/4				
ΡΠ-111316	1/2*	5/8			
ΡΠ-111616	5/8				
ΡΠ-111916	3/4				
ΡΠ-111319	1/2*	3/4			
ΡΠ-111919	3/4				
ΡΠ-112519	1"				
ΡΠ-111925	3/4*	1"4SH			
ΡΠ-112525	1"				
ΡΠ-113225	1"1/4				
ΡΠ-113232	1" 1/4	1" 1/4			
ΡΠ-113832	1" 1/2				
ΡΠ-113838	1" 1/2	1" 1/2			
ΡΠ-115050	2"	2"			
ΡΠ-116350	2"½	2"1/2			
ΡΠ-117575	3"	3"			



ΑΜΒΛΕΙΕΣ 45ο

ΡΠ-140305	1/8	3/16			
ΡΠ-140306	1/8	1/4			
ΡΠ-140606	1/4				
ΡΠ-141006	3/8				
ΡΠ-140608	1/4	5/16			
ΡΠ-141008	3/8				
ΡΠ-140610	1/4	3/8			
ΡΠ-141010	3/8				
ΡΠ-141310	1/2	1/2			
ΡΠ-141313	1/2				
ΡΠ-141616	5/8	5/8			
ΡΠ-141916	3/4				
ΡΠ-141919	3/4	3/4			
ΡΠ-142525	1"	1" 4SH			
ΡΠ-143232	1"1/4	1"1/4			
ΡΠ-143832	1"1/2				
ΡΠ-143838	1"1/2	1"1/2			
ΡΠ-145050	2"	2"			



ΓΩΝΙΕΣ COMPACT

ΚΩΔΙΚΟΣ	ΣΠΕΙΡΩΜΑ	ΟΥΡΑ	ΣΚΕΤΑ	ΚΟΜΠΛΕ	+ ΦΠΑ
ΡΠ-090606	1/4	1/4			
ΡΠ-091008	3/8	5/16			
ΡΠ-091010	3/8	3/8			
ΡΠ-091310	1/2	1/2			
ΡΠ-091313	1/2				
ΡΠ-091919	3/4	3/4			
ΡΠ-092525	1"	1"			



made in ITALY

Τα είδη με * είναι σειρά 60



ΑΡΣΕΝΙΚΑ N.P.T

ΚΩΔΙΚΟΣ	ΣΠΕΙΡΩΜΑ	ΟΥΡΑ	ΣΚΕΤΑ	ΚΟΜΠΛΕ	+ ΦΠΑ
ΡΠ-120303	1\8 γρασ/ρου 3/16				
ΡΠ-120305	1\8	3/16			
ΡΠ-120605	1\4				
ΡΠ-120306	1\8	1\4			
ΡΠ-120606	1\4				
ΡΠ-121006	3\8	5\16			
ΡΠ-120608	1\4				
ΡΠ-121008	3\8	3\8			
ΡΠ-121308	1\2				
ΡΠ-120610	1\4	3\8			
ΡΠ-121010	3\8				
ΡΠ-121310	1\2	1\2			
ΡΠ-121013	3\8				
ΡΠ-121313	1\2	5\8			
ΡΠ-121913	3\4				
ΡΠ-122513	1"	3\4			
ΡΠ-121916	3\4				
ΡΠ-121919	3\4	1"4SH			
ΡΠ-122519	1"				
ΡΠ-122525	1"	1" 1\4			
ΡΠ-123225	1"1\4				
ΡΠ-123232	1" 1\4	1" 1\2			
ΡΠ-123832	1" 1\2				
ΡΠ-123838	1" 1\2	2"			
ΡΠ-125050	2"				

ΑΡΣΕΝΙΚΑ B.S.P

ΚΩΔΙΚΟΣ	ΣΠΕΙΡΩΜΑ	ΟΥΡΑ	ΣΚΕΤΑ	ΚΟΜΠΛΕ	+ ΦΠΑ
ΡΠ-130305	1\8	3/16			
ΡΠ-130605	1\4				
ΡΠ-130306	1\8	1\4			
ΡΠ-130606	1\4				
ΡΠ-131006	3\8	5\16			
ΡΠ-131306	1\2				
ΡΠ-130608	1\4	3\8			
ΡΠ-131008	3\8				
ΡΠ-131308	1\2	1\2			
ΡΠ-130610	1\4				
ΡΠ-131010	3\8	5\8			
ΡΠ-131310	1\2				
ΡΠ-131013	3\8	3\4			
ΡΠ-131313	1\2				
ΡΠ-131613	5\8	1"4SH			
ΡΠ-131913	3\4				
ΡΠ-131316	1\2	1" 1\4			
ΡΠ-131616	5\8				
ΡΠ-131916	3\4	1" 1\2			
ΡΠ-131919	3\4				
ΡΠ-132519	1"	2"			
ΡΠ-132525	1"				
ΡΠ-133225	1"1\4				
ΡΠ-133232	1" 1\4				
ΡΠ-133832	1" 1\2				
ΡΠ-133838	1" 1\2				
ΡΠ-135050	2"				



ΑΡΣΕΝΙΚΑ B.S.P ΙΣΙΑ ΕΔΡΑ

ΚΩΔΙΚΟΣ	ΣΠΕΙΡΩΜΑ	ΟΥΡΑ	ΣΚΕΤΑ	ΚΟΜΠΛΕ	+ ΦΠΑ
ΡΠ-081010	3\8	3\8			
ΡΠ-081310	1\2				
ΡΠ-081313	1\2	1\2			
ΡΠ-081913	3\4				
ΡΠ-081919	3\4	3\4			

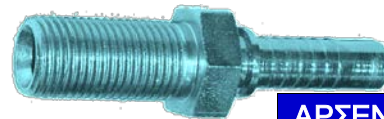

ΑΡΣΕΝΙΚΑ B.S.P ΚΟΝΤΡΑ

ΚΩΔΙΚΟΣ	ΣΠΕΙΡΩΜΑ	ΟΥΡΑ	ΣΚΕΤΑ	ΚΟΜΠΛΕ	+ ΦΠΑ
ΡΠ-130013	1\2	1\2			
ΡΠ-130016	5\8	5\8			
ΡΠ-130019	3\4	3\4			

ΑΡΣΕΝΙΚΑ ΚΩΝΟΣ U.N.F



ΚΩΔΙΚΟΣ	ΣΠΕΙΡΩΜΑ	ΟΥΡΑ	ΣΚΕΤΑ	ΚΟΜΠΛΕ	+ ΦΠΑ
ΡΠ-041010	3\8	3\8			
ΡΠ-041313	1\2	1\2			



ΘΗΛΥΚΑ ΙΣΙΑ ΕΔΡΑ

ΚΩΔΙΚΟΣ	ΣΠΕΙΡΩΜΑ	ΟΥΡΑ	ΣΚΕΤΑ	ΚΟΜΠΛΕ	+ ΦΠΑ
ΡΠ-100609	1\4	1\4			
ΡΠ-101009	3\8	3\8			
ΡΠ-101311	1\2				
ΡΠ-101314	1\2	1\2			
ΡΠ-101913	3\4				
ΡΠ-101917	3\4	5\8			
ΡΠ-101920	3\4	3\4			
ΡΠ-102524	1"	1"			

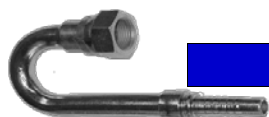

ΓΩΝΙΕΣ B.S.P 180°

ΚΩΔΙΚΟΣ	ΣΠΕΙΡΩΜΑ	ΟΥΡΑ	ΣΚΕΤΑ	ΚΟΜΠΛΕ	+ ΦΠΑ
ΡΠ-050006	1\4	1\4			
ΡΠ-050010	3\8	3\8			
ΡΠ-050013	1\2	1\2			



ΓΩΝΙΑ σπαστή JCB

ΚΩΔΙΚΟΣ	ΣΠΕΙΡΩΜΑ	ΟΥΡΑ	ΣΚΕΤΑ	ΚΟΜΠΛΕ	+ ΦΠΑ
ΡΠ-051314	1\2	1\2			
ΡΠ-051617	5\8	5\8			

ΡΑΚΟΡ ΒΙΔΩΤΑ



ΘΗΛΥΚΑ B.S.P. ΒΙΔΩΤΑ

ΚΩΔΙΚΟΣ	ΣΠΕΙΡΩΜΑ	ΟΥΡΑ	ΣΚΕΤΑ	ΚΟΜΠΛΕ	+ ΦΠΑ
ΒΔ-100606	1\4	1\4			
ΒΔ-101010	3\8	3\8			
ΒΔ-101313	1\2	1\2			
ΒΔ-101616	5\8	5\8			
ΒΔ-101919	3\4	3\4			
ΒΔ-102525	1"	1"			



ΓΩΝΙΕΣ 90° B.S.P ΒΙΔΩΤΑ

ΒΔ-110606	1\4	1\4			
ΒΔ-111010	3\8	3\8			
ΒΔ-111313	1\2	1\2			
ΒΔ-111616	5\8	5\8			
ΒΔ-111919	3\4	3\4			
ΒΔ-112525	1"	1"			



ΚΥΑΘΙΑ ΒΙΔΩΤΑ R2 καθαρισμένη

ΚΩΔΙΚΟΣ	ΣΠΕΙΡΩΜΑ	ΤΙΜΗ	+ ΦΠΑ
ΒΔ-310602	1\4		
ΒΔ-311002	3\8		
ΒΔ-311302	1\2		
ΒΔ-311602	5\8		
ΒΔ-311902	3\4		
ΒΔ-312502	1"		

ΚΥΑΘΙΑ ΒΙΔΩΤΑ R7 ακαθάριστη

ΒΔ-317006	1\4		
ΒΔ-317010	3\8		
ΒΔ-317013	1\2		



ΘΗΛΥΚΑ ΚΩΝΟΣ U.N.F 60° ΤΟΥΤΑ

ΚΩΔΙΚΟΣ	ΣΠΕΙΡΩΜΑ	ΟΥΡΑ	ΣΚΕΤΑ	ΚΟΜΠΛΕ	+ ΦΠΑ
ΡΠ-100607	1\4	1\4			
ΡΠ-101011	3\8	3\8			
ΡΠ-101312	1\2				
ΡΠ-101315	1\2	1\2			
ΡΠ-101921	3\4	3\4			
ΡΠ-102526	1"	1"			



ΓΩΝΙΕΣ κώνος UNF

ΚΩΔΙΚΟΣ	ΣΠΕΙΡΩΜΑ	ΟΥΡΑ	ΣΚΕΤΑ	ΚΟΜΠΛΕ	+ ΦΠΑ
ΡΠ-050606	1\4	1\4			
ΡΠ-051010	3\8	3\8			
ΡΠ-051310	1\2				
ΡΠ-051313	1\2	1\2			
ΡΠ-051919	3\4	3\4			



ΘΗΛΥΚΑ ΙΣΙΑ ΕΔΡΑ μετρικά για κινέζικα μηχ/τα

ΚΩΔΙΚΟΣ	ΣΠΕΙΡΩΜΑ	ΟΥΡΑ	ΣΚΕΤΑ	ΚΟΜΠΛΕ	+ ΦΠΑ
ΡΠ-501406	14X1,5	1\4			
ΡΠ-501608	16X1,5	5\16			
ΡΠ-501810	18X1,5	3\8			
ΡΠ-502213	22X1,5	1\2			
ΡΠ-502716	27X1,5	5\8			



ΓΩΝΙΕΣ ΙΣΙΑ ΕΔΡΑ μετρικές για κινέζικα μηχ/τα

ΚΩΔΙΚΟΣ	ΣΠΕΙΡΩΜΑ	ΟΥΡΑ	ΣΚΕΤΑ	ΚΟΜΠΛΕ	+ ΦΠΑ
ΡΠ-511406	14X1,5	1\4			
ΡΠ-511606	16X1,5				
ΡΠ-511608	16X1,5	5\16			
ΡΠ-511810	18X1,5	3\8			
ΡΠ-512213	22X1,5	1\2			
ΡΠ-512716	27X1,5	5\8			



ΘΗΛΥΚΑ ΑΖΩΤΟΥ-CO2 (21,8)

ισια εδρα

ΚΩΔΙΚΟΣ	ΣΠΕΙΡΩΜΑ	ΟΥΡΑ	ΣΚΕΤΑ	ΚΟΜΠΛΕ	+ ΦΠΑ
ΡΠ-162107	21,8	1\4			
ΡΠ-162111	21,8	3\8			
ΡΠ-162113	21,8	1\2			

ΜΑΣΤΟΣ ΑΖΩΤΟΥ-CO2 (21,8)

ΡΣ-072106	ΘΗΛ 21,8-ΑΡΣ 1/4				
-----------	------------------	--	--	--	--



ΡΑΚΟΡ ΜΕΤΡΙΚΑ

ΑΡΣΕΝΙΚΑ ΣΕΙΡΑ L

24ο ΕΔΡΑ



ΘΗΛΥΚΑ ΣΕΙΡΑ L

24ο ΕΔΡΑ

ΚΩΔΙΚΟΣ	ΣΠΕΙΡΩΜΑ	ΣΩΛΗΝΑ	ΕΔΡΑ	ΣΚΕΤΑ	ΚΟΜΠΛΕ	+ ΦΠΑ
ΡΠ-150505	10X1	* 3/16	6LL			
ΡΠ-151205	12X1,5		6L			
ΡΠ-151405	14X1,5		8L			
ΡΠ-151206	12X1,5	1/4	6L			
ΡΠ-151406	14X1,5		8L			
ΡΠ-151606	16X1,5		10L			
ΡΠ-151806	18X1,5		12L			
ΡΠ-151408	14X1,5	5/16	8L			
ΡΠ-151608	16X1,5		10L			
ΡΠ-151808	18X1,5	3/8	12L			
ΡΠ-151610	16X1,5		10L			
ΡΠ-151810	18X1,5		12L			
ΡΠ-152210	22X1,5	1/2	15L			
ΡΠ-151813	18X1,5		12L			
ΡΠ-152213	22X1,5		15L			
ΡΠ-152613	26X1,5		18L			
ΡΠ-152216	22X1,5	5/8	15L			
ΡΠ-152616	26X1,5		18L			
ΡΠ-152619	26X1,5	3/4	18L			
ΡΠ-153019	30X2		22L			
ΡΠ-153625	36X2	1"	28L			
ΡΠ-154525	45X2		35L			
ΡΠ-154532	45X2	1"1/4	35L			
ΡΠ-155238	52X2	1"1/2	42L			

ΑΡΣΕΝΙΚΑ ΣΕΙΡΑ S

ΡΠ-150605	14X1,5	* 3/16	6S			
ΡΠ-150805	16X1,5		8S			
ΡΠ-150606	14X1,5	1/4	6S			
ΡΠ-150806	16X1,5		8S			
ΡΠ-151006	18X1,5		10S			
ΡΠ-152006	20X1,5	5/16	12S			
ΡΠ-151008	18X1,5		10S			
ΡΠ-152008	20X1,5	3/8	12S			
ΡΠ-151010	18X1,5		10S			
ΡΠ-152010	20X1,5		12S			
ΡΠ-152211	22X1,5	1/2	14S			
ΡΠ-152013	20X1,5		12S			
ΡΠ-152214	22X1,5	5/8	14S			
ΡΠ-152413	24X1,5		16S			
ΡΠ-153016	30X2		20S			
ΡΠ-153022	30X2	3/4	20S			
ΡΠ-153619	36X2		25S			
ΡΠ-154219	42X2	1"	30S			
ΡΠ-153626	36X2		25S			
ΡΠ-154225	42X2		30S			
ΡΠ-155225	52X2	1"1/4	38S			
ΡΠ-154232	42X2		30S			
ΡΠ-155232	52X2		38S			

ΑΡΣΕΝΙΚΑ ΚΟΝΤΡΑ



ΚΩΔΙΚΟΣ	ΣΠΕΙΡΩΜΑ	ΣΩΛΗΝ	ΕΔΡΑ	ΣΚΕΤΑ	ΚΟΜΠΛΕ	+ ΦΠΑ
ΡΠ-150612	12X1,5	1/4	6L			
ΡΠ-151210	18X1,5	3/8	12L			
ΡΠ-151513	22X1,5	1/2	15L			

*Σέ 3/16 σειρά 80 cast

■ ρακόρ ίδιο με σειρά 60

ΚΩΔΙΚΟΣ	ΣΠΕΙΡΩΜΑ	ΣΩΛΗΝΑ	ΕΔΡΑ	ΣΚΕΤΑ	ΚΟΜΠΛΕ	+ ΦΠΑ
ΡΠ-161203	12X1,5	1/8	6L			
ΡΠ-161204	12X1,5	5/32	6L			
ΡΠ-161205	12X1,5	* 3/16	6L			
ΡΠ-161405	14X1,5		8L			
ΡΠ-161206	12X1,5	1/4	6L			
ΡΠ-161406	14X1,5		8L			
ΡΠ-161606	16X1,5		10L			
ΡΠ-161806	18X1,5		12L			
ΡΠ-161408	14X1,5	5/16	8L			
ΡΠ-161608	16X1,5		10L			
ΡΠ-161808	18X1,5	3/8	12L			
ΡΠ-161610	16X1,5		10L			
ΡΠ-161810	18X1,5		12L			
ΡΠ-162210	22X1,5	1/2	15L			
ΡΠ-161813	18X1,5		12L			
ΡΠ-162213	22X1,5	5/8	15L			
ΡΠ-162613	26X1,5		18L			
ΡΠ-162216	22X1,5		15L			
ΡΠ-162616	26X1,5	3/4	18L			
ΡΠ-163017	30X2		22L			
ΡΠ-162619	26X1,5	1"	18L			
ΡΠ-163019	30X2		22L			
ΡΠ-163625	36X2	1"1/4	28L			
ΡΠ-164525	45X2		35L			
ΡΠ-164532	45X2	1"1/2	35L			
ΡΠ-165233	52X2		42L			
ΡΠ-165238	52X2	42L				

ΘΗΛΥΚΑ ΣΕΙΡΑ S

ΡΠ-160603	14X1,5	1/8	6S			
ΡΠ-160605	14X1,5	* 3/16	6S			
ΡΠ-160805	16X1,5		8S			
ΡΠ-160606	14X1,5	1/4	6S			
ΡΠ-160806	16X1,5		8S			
ΡΠ-161006	18X1,5		10S			
ΡΠ-162006	20X1,5	5/16	12S			
ΡΠ-161008	18X1,5		10S			
ΡΠ-162008	20X1,5	3/8	12S			
ΡΠ-161010	18X1,5		10S			
ΡΠ-162010	20X1,5		12S			
ΡΠ-162211	22X1,5	1/2	14S			
ΡΠ-162410	24X1,5		16S			
ΡΠ-162013	20X1,5	5/8	12S			
ΡΠ-162214	22X1,5		14S			
ΡΠ-162413	24X1,5		16S			
ΡΠ-162416	24X1,5	1"	16S			
ΡΠ-163016	30X2		20S			
ΡΠ-162419	24X1,5	3/4	16S			
ΡΠ-163022	30X2		20S			
ΡΠ-163619	36X2		25S			
ΡΠ-164219	42X2	1"1/4	30S			
ΡΠ-163626	36X2		25S			
ΡΠ-164225	42X2	1"1/2	30S			
ΡΠ-165225	52X2		38S			
ΡΠ-164232	42X2	1"	30S			
ΡΠ-165232	52X2		38S			
ΡΠ-163838	52X2	38S				

ΡΑΚΟΡ ΜΕΤΡΙΚΑ



ΓΩΝΙΕΣ 90° ΣΕΙΡΑ L

24ο ΕΔΡΑ



24ο ΕΔΡΑ

ΚΩΔΙΚΟΣ	ΣΠΕΙΡΩΜΑ	ΣΩΛΗΝΑ	ΕΔΡΑ	ΣΚΕΤΑ	ΚΟΜΠΛΕ	+ ΦΠΑ
ΡΠ-171203	12X1,5	1\8	6L			
ΡΠ-171204	12X1,5	5\32	6L			
ΡΠ-171205	12X1,5	* 3\16	6L			
ΡΠ-171405	14X1,5		8L			
ΡΠ-171206	12X1,5		6L			
ΡΠ-171406	14X1,5	1\4	8L			
ΡΠ-171606	16X1,5		10L			
ΡΠ-171806	18X1,5		12L			
ΡΠ-171408	14X1,5		8L			
ΡΠ-171608	16X1,5	5\16	10L			
ΡΠ-171808	18X1,5		12L			
ΡΠ-171610	16X1,5		10L			
ΡΠ-171810	18X1,5	3\8	12L			
ΡΠ-172210	22X1,5		15L			
ΡΠ-171813	18X1,5		12L			
ΡΠ-172213	22X1,5	1\2	15L			
ΡΠ-172613	26X1,5		18L			
ΡΠ-172216	22X1,5		15L			
ΡΠ-172616	26X1,5	5\8	18L			
ΡΠ-173017	30X2		22L			
ΡΠ-172619	26X1,5	3\4	18L			
ΡΠ-173019	30X2		22L			
ΡΠ-173625	36X2	1"4SH	28L			
ΡΠ-174525	45X2		35L			
ΡΠ-174532	45X2	1"1\4	35L			
ΡΠ-175233	52X2		42L			
ΡΠ-175238	52X2	1"1\2	42L			

ΓΩΝΙΕΣ 90° ΣΕΙΡΑ S

ΡΠ-170603	14X1,5	1\8	6S			
ΡΠ-170605	14X1,5	* 3\16	6S			
ΡΠ-170805	16X1,5		8S			
ΡΠ-170606	14X1,5		6S			
ΡΠ-170806	16X1,5	1\4	8S			
ΡΠ-171006	18X1,5		10S			
ΡΠ-172006	20X1,5		12S			
ΡΠ-171008	18X1,5		10S			
ΡΠ-172008	20X1,5	5\16	12S			
ΡΠ-170810	16X1,5		8S			
ΡΠ-171010	18X1,5	3\8	10S			
ΡΠ-172010	20X1,5		12S			
ΡΠ-172211	22X1,5		14S			
ΡΠ-172013	20X1,5		12S			
ΡΠ-172214	22X1,5	1\2	14S			
ΡΠ-172413	24X1,5		16S			
ΡΠ-173016	30X2	5\8	20S			
ΡΠ-173022	30X2		20S			
ΡΠ-173619	36X2	3\4	25S			
ΡΠ-174219	42X2		30S			
ΡΠ-173626	36X2	1"4SH	25S			
ΡΠ-174225	42X2		30S			
ΡΠ-174232	42X2		30S			
ΡΠ-175232	52X2	1"1\4	38S			
ΡΠ-173838	52X2	1" 1\2	38S			

ΑΜΒΛΙΕΣ 45° ΣΕΙΡΑ L

ΚΩΔΙΚΟΣ	ΣΠΕΙΡΩΜΑ	ΣΩΛΗΝΑ	ΕΔΡΑ	ΣΚΕΤΑ	ΚΟΜΠΛΕ	+ ΦΠΑ
ΡΠ-381205	12X1,5	* 3\16	6L			
ΡΠ-381405	14X1,5		8L			
ΡΠ-381206	12X1,5		6L			
ΡΠ-381406	14X1,5	1\4	8L			
ΡΠ-381606	16X1,5		10L			
ΡΠ-381806	18X1,5		12L			
ΡΠ-381408	14X1,5		8L			
ΡΠ-381608	16X1,5	5\16	10L			
ΡΠ-381808	18X1,5		12L			
ΡΠ-381610	16X1,5		10L			
ΡΠ-381810	18X1,5	3\8	12L			
ΡΠ-382210	22X1,5		15L			
ΡΠ-381813	18X1,5		12L			
ΡΠ-382213	22X1,5	1\2	15L			
ΡΠ-382613	26X1,5		18L			
ΡΠ-382616	26X1,5		18L			
ΡΠ-383017	30X2	5\8	22L			
ΡΠ-382619	26X1,5	3\4	18L			
ΡΠ-383019	30X2		22L			
ΡΠ-383625	36X2	1"4SH	28L			
ΡΠ-384525	45X2		35L			
ΡΠ-384532	45X2	1"1\4	35L			
ΡΠ-385238	52X2	1"1\2	42L			

ΑΜΒΛΙΕΣ 45° ΣΕΙΡΑ S



ΡΠ-380605	12X1,5	* 3\16	6S			
ΡΠ-380805	16X1,5		8S			
ΡΠ-380606	14X1,5		6S			
ΡΠ-380806	16X1,5	1\4	8S			
ΡΠ-381006	18X1,5		10S			
ΡΠ-382006	20X1,5		12S			
ΡΠ-381008	18X1,5		10S			
ΡΠ-382008	20X1,5	5\16	12S			
ΡΠ-381010	18X1,5		10S			
ΡΠ-382010	20X1,5	3\8	12S			
ΡΠ-382211	22X1,5		14S			
ΡΠ-382013	20X1,5		12S			
ΡΠ-382214	22X1,5	1\2	14S			
ΡΠ-382413	24X1,5		16S			
ΡΠ-383016	30X2	5\8	20S			
ΡΠ-383022	30X2	3\4	20S			
ΡΠ-383619	36X2		25S			
ΡΠ-383626	36X2	1"4SH	25S			
ΡΠ-384225	42X2		30S			
ΡΠ-384232	42X2	1"1\4	30S			
ΡΠ-385232	52X2		38S			

*Σέ ουρά 3/16 χρησιμοποιείται η σειρά 80 cast
 ■ ρακόρ ίδιο με σειρά 60



ΡΑΚΟΡ ΓΙΑ ΠΕΡΑΣΤΟ ΠΑΞΙΜΑΔΙ

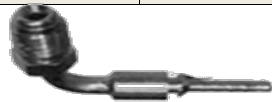

RZ						RZ 90o						
ΚΩΔΙΚΟΣ	ΠΕΡΙΓΡΑΦΗ	ΣΩΛΗΝΑ	ΣΚΕΤΑ	ΚΟΜΠΛΕ	+ ΦΠΑ	ΚΩΔΙΚΟΣ	ΠΕΡΙΓΡΑΦΗ	ΣΩΛΗΝΑ	ΣΚΕΤΑ	ΚΟΜΠΛΕ	+ ΦΠΑ	
ΡΠ-180403	4LL	1/8				ΡΠ-190603	6L-S	1/8				
ΡΠ-180603	6L-S					ΡΠ-190604	6L-S	5/32				
ΡΠ-180604	6L-S	5/32				ΡΠ-190605	6L-S	3/16				
ΡΠ-180405	4LL				ΡΠ-190805	8L-S						
ΡΠ-180605	6L-S	3/16				ΡΠ-190606	6L-S	1/4				
ΡΠ-180805	8L-S					ΡΠ-190806	8L-S					
ΡΠ-180606	6L-S	1/4				ΡΠ-191006	10L-S					
ΡΠ-180806	8L-S					ΡΠ-191206	12L-S					
ΡΠ-181006	10L-S	5/16				ΡΠ-190808	8L-S	5/16				
ΡΠ-181206	12L-S					ΡΠ-191008	10L-S					
ΡΠ-180808	8L-S	3/8				ΡΠ-191208	12L-S	3/8				
ΡΠ-181008	10L-S					ΡΠ-191010	10L-S					
ΡΠ-181208	12L-S	1/2				ΡΠ-191210	12L-S	1/2				
ΡΠ-181010	10L-S					ΡΠ-191410	14S					
ΡΠ-181210	12L-S	5/8				ΡΠ-191510	15L	5/8				
ΡΠ-181410	14S					ΡΠ-191413	14S					
ΡΠ-181510	15L	3/4				ΡΠ-191513	15L	3/4				
ΡΠ-181213	12L-S					ΡΠ-191613	16S					
ΡΠ-181413	14S	1/2				ΡΠ-191813	18L	1/2				
ΡΠ-181513	15L					ΡΠ-191816	18L					
ΡΠ-181613	16S	5/8				ΡΠ-192016	20S	5/8				
ΡΠ-181813	18L					ΡΠ-192019	20S					
ΡΠ-181616	16S	3/4				ΡΠ-192219	22L	3/4				
ΡΠ-181816	18L					ΡΠ-192519	25S					
ΡΠ-182016	20S	1"4SH									RZ 45°	
ΡΠ-182019	20S					ΡΠ-380604	6	5/32				
ΡΠ-182219	22L	1" 1/4				ΡΠ-370605	6	3/16				
ΡΠ-182519	25S										ΒΙΔΩΤΑ ΚΟΥΒΟΥΚΛΙΩΝ	
ΡΠ-182525	25S	1" 1/2				ΚΩΔΙΚΟΣ	ΤΥΠΟΣ ΒΙΔΩΤΟΥ		ΚΟΜΠΛΕ	+ ΦΠΑ		
ΡΠ-182825	28L					ΒΔ-180604	ΙΣΙΟ 6L-S -4mm(5/32)					
ΡΠ-183025	30S	3/8				ΒΔ-180605	ΙΣΙΟ 6L-S -3/16					
ΡΠ-183525	35L					ΒΔ-190604	ΓΩΝΙΑ 6L-S -4mm(5/32)					
ΡΠ-183532	35L	1/4				ΒΔ-190605	ΓΩΝΙΑ 6L-S -3/16					
ΡΠ-183832	38S											ΑΡΣΕΝΙΚΑ 90°ΤΡΕΛΛΑ
ΡΠ-184238	42L					ΑΡΣΕΝΙΚΑ ΤΡΕΛΛΑ						
ΡΠ-441005	10X1	3/16				ΡΠ-450905	3/8X24	3/16				
ΡΠ-441205	12X1					ΡΠ-451106	7/16X24	1/4				
ΡΠ-440905	3/8X24	1/4				ΡΠ-451308	1/2X20	5/16				
ΡΠ-441105	7/16X24					ΡΠ-451510	5/8X18	3/8				
ΡΠ-441106	7/16X24	5/16				ΡΠ-451205	12X1	3/16				
ΡΠ-441206	12X1					ΡΠ-451206	12X1	1/4				
ΡΠ-441406	14X1	3/8				ΡΠ-451407	14X1					
ΡΠ-441308	1/2X20					ΡΠ-451610	16X1,5	3/8				
ΡΠ-441610	16X1,5	1/2			ΡΠ-451910	3/4X18						
ΡΠ-441810	18X1,5					ΡΠ-451913	3/4X16	1/2				
ΡΠ-441510	5/8X18				ΡΠ-451914	3/4X18						
ΡΠ-442213	22X1,5	7/8X18				ΡΠ-451912	7/8X18					
ΡΠ-441914	3/4X18											
ΡΠ-447813	7/8X18											



ΘΗΛΥΚΑ ΜΕΤΡΙΚΑ 60° κώνο

ΚΩΔΙΚΟΣ	ΣΠΕΙΡΩΜΑ	ΟΥΡΑ	ΣΚΕΤΑ	ΚΟΜΠΛΕ	+ ΦΠΑ
ΡΠ-481005	10X1				
ΡΠ-481205	12X1,5	3\16			
ΡΠ-481605	16X1,5				
ΡΠ-481006	10X1				
ΡΠ-481206	12X1,5	1\4			
ΡΠ-481406	14X1,5				
ΡΠ-481606	16X1,5				
ΡΠ-481408	14X1,5				
ΡΠ-481608	16X1,5	5\16			
ΡΠ-481808	18X1,5				
ΡΠ-481410	14X1,5				
ΡΠ-481610	16X1,5				
ΡΠ-481810	18X1,5	3\8			
ΡΠ-482010	20X1,5				
ΡΠ-482210	22X1,5				
ΡΠ-481813	18X1,5				
ΡΠ-482013	20X1,5	1\2			
ΡΠ-482213	22X1,5				
ΡΠ-482613	26X1,5				
ΡΠ-482616	26X1,5	5\8			
ΡΠ-482619	26X1,5	3\4			
ΡΠ-483825	38X1,5	1"			



ΑΡΣΕΝΙΚΑ ΜΕΤΡΙΚΑ 60° κώνο & βάση

ΚΩΔΙΚΟΣ	ΣΠΕΙΡΩΜΑ	ΟΥΡΑ	ΣΚΕΤΑ	ΚΟΜΠΛΕ	+ ΦΠΑ
ΡΠ-461205	12X1,5	3\16			
ΡΠ-461206	12X1,5				
ΡΠ-461406	14X1,5	1\4			
ΡΠ-461606	16X1,5				
ΡΠ-461408	14X1,5				
ΡΠ-461608	16X1,5	5\16			
ΡΠ-461808	18X1,5				
ΡΠ-461410	14X1,5				
ΡΠ-461610	16X1,5				
ΡΠ-461810	18X1,5	3\8			
ΡΠ-462010	20X1,5				
ΡΠ-462210	22X1,5				
ΡΠ-461813	18X1,5				
ΡΠ-462013	20X1,5	1\2			
ΡΠ-462213	22X1,5				
ΡΠ-462613	26X1,5				
ΡΠ-462616	26X1,5	5\8			
ΡΠ-463825	38X1,5	1"			



90 ° ΜΕΤΡΙΚΕΣ 60° κώνο

ΚΩΔΙΚΟΣ	ΣΠΕΙΡΩΜΑ	ΟΥΡΑ	ΣΚΕΤΑ	ΚΟΜΠΛΕ	+ ΦΠΑ
ΡΠ-471205	12X1,5	3\16			
ΡΠ-471206	12X1,5				
ΡΠ-471406	14X1,5	1\4			
ΡΠ-471606	16X1,5				
ΡΠ-471408	14X1,5				
ΡΠ-471608	16X1,5	5\16			
ΡΠ-471808	18X1,5				
ΡΠ-471410	14X1,5				
ΡΠ-471610	16X1,5				
ΡΠ-471810	18X1,5	3\8			
ΡΠ-472010	20X1,5				
ΡΠ-472210	22X1,5				
ΡΠ-471813	18X1,5				
ΡΠ-472013	20X1,5	1\2			
ΡΠ-472213	22X1,5				
ΡΠ-472613	26X1,5				
ΡΠ-472616	26X1,5	5\8			
ΡΠ-472619	26X1,5	3\4			
ΡΠ-473825	38X1,5	1"			

ΘΗΛΥΚΑ ΓΑΛΛΙΚΟΥ ΤΥΠΟΥ

ΚΩΔΙΚΟΣ	ΣΠΕΙΡΩΜΑ	ΣΙΔ/ΝΑ	ΣΚΕΤΑ	ΚΟΜΠΛΕ	+ ΦΠΑ
ΡΠ-162014	20X1,5-1/2	13,25			
ΡΠ-162414	24X1,5-1/2	16,75			
ΡΠ-163116	30X1,5-5/8	21,25			
ΡΠ-163020	30X1,5-3/4	21,25			
ΡΠ-163621	36X1,5-3/4	26,75			
ΡΠ-164526	45X1,5- 1"	33,5			
ΡΠ-164533	45X1,5-1¼	33,5			



ΑΡΣΕΝΙΚΑ ΓΑΛΛΙΚΟΥ ΤΥΠΟΥ

ΚΩΔΙΚΟΣ	ΣΠΕΙΡΩΜΑ	ΣΙΔ/ΝΑ	ΣΚΕΤΑ	ΚΟΜΠΛΕ	+ ΦΠΑ
ΡΠ-152014	20X1,5-1/2	13,25			
ΡΠ-152414	24X1,5-1/2	16,75			
ΡΠ-153116	30X1,5-5/8	21,25			
ΡΠ-153021	30X1,5-3/4	21,25			
ΡΠ-153621	36X1,5-3/4	26,75			
ΡΠ-154526	45X1,5 - 1"	33,50			
ΡΠ-154533	45X1,5-1¼	33,50			



45 ° ΜΕΤΡΙΚΕΣ 60° κώνο

ΡΠ-451406	14X1,5	1\4			
ΡΠ-451810	18X1,5	3\8			
ΡΠ-452619	26X1,5	5\8			

ΓΩΝΙΕΣ ΓΑΛΛΙΚΟΥ ΤΥΠΟΥ

ΚΩΔΙΚΟΣ	ΣΠΕΙΡΩΜΑ	ΣΙΔ/ΝΑ	ΣΚΕΤΑ	ΚΟΜΠΛΕ	+ ΦΠΑ
ΡΠ-172014	20X1,5-1/2	13,25			
ΡΠ-172414	24X1,5-1/2	16,75			
ΡΠ-173116	30X1,5-5/8	21,25			
ΡΠ-173020	30X1,5-3/4	21,25			
ΡΠ-173621	36X1,5-3/4	26,75			
ΡΠ-174526	45X1,5-1"	33,50			
ΡΠ-174533	45X1,5-1¼	33,50			

ΡΑΚΟΡ ΠΛΥΣΤΙΚΩΝ ΜΗΧΑΝΗΜΑΤΩΝ



BOSH FAIP

ΣΚΕΤΟ ΚΟΜΠΛΕ + ΦΠΑ

RP-160009	ONE AF	1\4	D11,5			
-----------	--------	-----	-------	--	--	--



ΓΩΝΙΑ 22X1,5 ΠΛΥΣΤΙΚΩΝ

ΚΩΔΙΚΟΣ	ΠΕΡΙΓΡΑΦΗ	ΣΩΛΗΝΑ		ΣΚΕΤΟ	ΚΟΜΠΛΕ	+ ΦΠΑ
RP-162206	22X1,5	1\4	D.14			
RP-162208	22X1,5	5\16	D.14			
RP-162209	22X1,5	3\8	D.14			
RP-162215	22X1,5	1\2	D.14			
RP-160004	22X1,5	1\4	D.15			
RP-162106	21X1,5	1\4	D.14			
RP-162108	21X1,5	5\16	D.14			
RP-162110	21X1,5	3\8	D.14			
RP-161306	1\2	1\4	D.14			
RP-161308	1\2	5\16	D.14			

RP-172206	22X1,5	1\4	D.14			
RP-172208	22X1,5	5\16	D.14			
RP-160020	22X1,5	1\4	D.15			
RP-160014	22X1,5	5\16	D.15			



ΘΗΛΥΚΑ 22X1,5 Μακρύ παξιμάδι για Karcher

ΚΩΔΙΚΟΣ	ΠΕΡΙΓΡΑΦΗ	ΣΩΛΗΝ		ΣΚΕΤΟ	ΚΟΜΠΛΕ	+ ΦΠΑ
RP-160622	22X1,5	1\4	D.14			
RP-160822	22X1,5	5\16	D.14			
RP-161022	22X1,5	3\8	D.14			



KARCHER PISTOL D 10,5

RP-160000	GRIP 610	1\4	D10,5			
RP-160007	GRIP 610	5\16	D10,5			
RP-160013	GRIP ανέμης- 1\4	1\4	D10,5			



ΘΗΛΥΚΑ 22X1,5 "K"

Μακρύ παξιμάδι & πλαστική χούφτα για πλυστικά Karcher

RP-16k622	22X1,5	1\4	D.14			
RP-16k822	22X1,5	5\16	D.14			



KARCHER PISTOL D 11

GRIP σιδερένιο INOX ΡΟΥΛΕΜΑΝ (D11)

RP-160018	GRIP 990	1\4	D.11			
RP-160019	GRIP 990	5\16	D.11			



Easy lock

Μακρύ παξιμάδι & πλαστική χούφτα για πλυστικά Karcher

Σπειρωμα 4 αρχών γρήγορο βιδωμα

RP-164622	E. L.	1\4	D.14			
RP-164822	E. L.	5\16	D.14			



GRIP 990 ΣΙΔΕΡΕΝΙΟ (D11) 3 ΡΟΔΕΛΕΣ

RP-160017	GRIP 990	1\4	D.11			
RP-160012	GRIP 990	5\16	D.11			



για KARCHER ΑΕΡΟΚΩΔΩΝΑ

RP-151814	18X1,5	1/2	D.14			
RP-152217	22X1,5		D.16,9			
RP-152215	22X1,5		D.18,9			
RP-160025	GRIP		D.14			



KARCHER PISTOL

RP-160015	KARCHER	1\4	D.8,7			
-----------	---------	-----	-------	--	--	--

NILFISK-STIHL

RP-160008	NILFISK	1\4	D. 8			
-----------	---------	-----	------	--	--	--

ANNOVI - BLACK&DECKER

RP-160016	A/R & BD	1\4	D 9			
-----------	----------	-----	-----	--	--	--

BOSCH

RP-160022	BOSCH	1\4	D 8			
-----------	-------	-----	-----	--	--	--

LAVOR

RP-160010	LAVOR	1\4	D 9			
-----------	-------	-----	-----	--	--	--

PARKSIDE

RP-160027	PARKSIDE	1\4	D.8,8			
-----------	----------	-----	-------	--	--	--



ΕΛΑΣΤΙΚΕΣ ΧΟΥΦΤΕΣ

ΑΠ-160000	ΜΑΥΡΗ	1\4				
ΑΠ-160001	ΜΑΥΡΗ	5\16				
ΑΠ-160002	ΜΑΥΡΗ	3\8				
ΑΠ-160003	ΜΠΛΕ	5\16				
ΑΠ-160004	ΜΠΛΕ	3\8				
ΑΠ-160006	ΜΑΥΡΗ HOBBY	d14				



**ΘΗΛΙΕΣ
ΠΙΕΣΕΩΣ
ΜΕΤΡΙΚΕΣ**



**ΘΗΛΙΕΣ 90°
ΚΑΘΕΤΕΣ
ΜΕΤΡΙΚΕΣ**

ΚΩΔΙΚΟΣ	mm	ΟΥΡΑ	ΣΚΕΤΑ	ΚΟΜΠΛΕ	+ ΦΠΑ	ΚΩΔΙΚΟΣ	mm	ΟΥΡΑ	ΣΚΕΤΑ	ΚΟΜΠΛΕ	+ ΦΠΑ
ΡΠ-270805	8	3/16				ΡΠ-561005	10	3/16			
ΡΠ-271005	10					ΡΠ-561006	10	1/4			
ΡΠ-271205	12					ΡΠ-561206	12				
ΡΠ-271405	14					ΡΠ-561406	14				
ΡΠ-271006	10	1/4				ΡΠ-561610	16	3/8			
ΡΠ-271206	12					ΡΠ-561810	18	1/2			
ΡΠ-271406	14					ΡΠ-562213	22				
ΡΠ-271606	16										
ΡΠ-271008	10	5/16									
ΡΠ-271208	12										
ΡΠ-271408	14										
ΡΠ-271608	16										
ΡΠ-271210	12	3/8				ΡΠ-571005	10	3/16			
ΡΠ-271410	14					ΡΠ-571006	10	1/4			
ΡΠ-271610	16					ΡΠ-571206	12				
ΡΠ-271810	18					ΡΠ-571406	14				
ΡΠ-271813	18	1/2				ΡΠ-571610	16	3/8			
ΡΠ-272013	20					ΡΠ-571810	18				
ΡΠ-272213	22					ΡΠ-572213	22	1/2			
ΡΠ-272216	22		5/8								
ΡΠ-272616	26										
ΡΠ-272619	26	3/4									
ΡΠ-273025	30	1"									



**ΘΗΛΙΕΣ 45°
ΟΡΙΖΟΝΤΙΕΣ
ΜΕΤΡΙΚΕΣ**

ΚΩΔΙΚΟΣ	mm	ΟΥΡΑ	ΣΚΕΤΑ	ΚΟΜΠΛΕ	+ ΦΠΑ	ΚΩΔΙΚΟΣ	mm	ΟΥΡΑ	ΣΚΕΤΑ	ΚΟΜΠΛΕ	+ ΦΠΑ
ΡΠ-571005	10	3/16				ΡΠ-581005	10	3/16			
ΡΠ-571006	10	1/4				ΡΠ-581006	10	1/4			
ΡΠ-571206	12					ΡΠ-581206	12				
ΡΠ-571406	14	3/8				ΡΠ-581406	14	3/8			
ΡΠ-571610	16					ΡΠ-581610	16				
ΡΠ-571810	18	1/2				ΡΠ-581810	18	1/2			
ΡΠ-572213	22					ΡΠ-582213	22				
ΡΠ-581005	10	3/16									
ΡΠ-581006	10	1/4									
ΡΠ-581206	12										
ΡΠ-581406	14	3/8									
ΡΠ-581610	16										
ΡΠ-581810	18	1/2									
ΡΠ-582213	22										



**ΘΗΛΙΕΣ 45°
ΚΑΘΕΤΕΣ
ΜΕΤΡΙΚΕΣ**

ΚΩΔΙΚΟΣ	mm	ΟΥΡΑ	ΣΚΕΤΑ	ΚΟΜΠΛΕ	+ ΦΠΑ	ΚΩΔΙΚΟΣ	mm	ΟΥΡΑ	ΣΚΕΤΑ	ΚΟΜΠΛΕ	+ ΦΠΑ
ΡΠ-551005	10	3/16				ΡΠ-551306	1/4	1/4			
ΡΠ-551006	10	1/4				ΡΠ-551706	3/8				
ΡΠ-551206	12						ΡΠ-551708	3/8	5/16		
ΡΠ-551406	14	3/8				ΡΠ-551710	3/8	3/8			
ΡΠ-551610	16					ΡΠ-552110	1/2				
ΡΠ-551810	18	1/2				ΡΠ-552113	1/2	1/2			
ΡΠ-552213	22										



**ΘΗΛΙΕΣ 90°
ΟΡΙΖΟΝΤΙΕΣ
ΜΕΤΡΙΚΕΣ**



**ΘΗΛΙΕΣ 90°
ΚΑΘΕΤΕΣ
B.S.P**



ΘΗΛΙΕΣ 45° ΟΡΙΖΟΝΤΙΕΣ B.S.P

ΚΩΔΙΚΟΣ	ΘΗΛΙΑ	ΣΙΔ/ΝΑΣ	ΜΗΚΟΣ	€	€ +ΦΠΑ
ΡΠ-571306	1/4	1/4			
ΡΠ-571706	3/8	1/4			
ΡΠ-571708	3/8	5/16			
ΡΠ-571710	3/8	3/8			
ΡΠ-572110	1/2	3/8			
ΡΠ-572113	1/2	1/2			



ΘΗΛΙΕΣ 45° ΚΑΘΕΤΕΣ B.S.P

ΚΩΔΙΚΟΣ	ΘΗΛΙΑ	ΣΙΔ/ΝΑΣ	ΜΗΚΟΣ	€	€ +ΦΠΑ
ΡΠ-581306	1/4	1/4			
ΡΠ-581706	3/8	1/4			
ΡΠ-581708	3/8	5/16			
ΡΠ-581710	3/8	3/8			
ΡΠ-582110	1/2	3/8			
ΡΠ-582113	1/2	1/2			

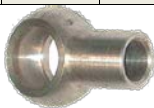

ΘΗΛΙΕΣ ΚΟΛΗΤΕΣ

ΚΩΔΙΚΟΣ	mm	Σ\ΝΑ	€	+ ΦΠΑ
ΡΠ-280008	8	6		
ΡΠ-280010	10	6		
ΡΠ-280012	12	8		
ΡΠ-280014	14	10		
ΡΠ-280016	16	12		
ΡΠ-280018	18	15		
ΡΠ-280020	20	16		
ΡΠ-280022	22	18		
ΡΠ-280026	26	20		
ΡΠ-280030	30	28		
ΡΠ-280013	1/2	14		



ΘΗΛΙΕΣ ΚΟΛΗΤΕΣ ΔΙΠΛΕΣ

ΚΩΔΙΚΟΣ	mm	Σ\ΝΑ	€	+ ΦΠΑ
ΡΠ-280208	8	5		
ΡΠ-280210	10	6		
ΡΠ-280212	12	8		
ΡΠ-280214	14	10		



ΘΗΛΙΑ με παξιμάδι και μπιμπίκι.

ΚΩΔΙΚΟΣ	ΘΗΛΙΑ	ΠΑΞΙ/ΔΙ	€	€ +ΦΠΑ
ΡΠ-281206	1/4	12L		
ΡΠ-281210	3/8	12L		
ΡΠ-281512	1/2	15L		
ΡΠ-281812	18mm	12L		

ΛΑΔΟΒΙΔΕΣ ΜΟΝΕΣ

ΜΕΤΡΙΚΕΣ

ΚΩΔΙΚΟΣ	ΣΠΕΙΡΩΜΑ	€	+ ΦΠΑ
PX-003031	6 X 1		
PX-003030	8 X 1		
PX-003032	8X1,25		
PX-003033	8X1,5		
PX-003040	10 X 1		
PX-003041	10X1,25		
PX-003042	10X1,5		
PX-003043	12X1		
PX-003044	12X1,25		
PX-003050	12 X 1,5		
PX-003060	14 X 1,5		
PX-003070	16 X 1,5		
PX-003080	18 X 1,5		
PX-003084	20 X 1,5		
PX-003081	22 X 1,5		
PX-003085	24 X 1,5		
PX-003082	26 X 1,5		
PX-003083	30 X 1,5		

B.S.P.

PX-003906	1/8 BSP		
PX-003091	1/4 BSP		
PX-003092	3/8 BSP		
PX-003093	1/2 BSP		
PX-003094	3/4 BSP		
PX-003095	1" BSP		

U.N.F.

PX-003088	3/8X24		
PX-003089	7/16X20		
PX-003090	1/2 X 20		

ΛΑΔΟΒΙΔΕΣ ΔΙΠΛΕΣ

ΜΕΤΡΙΚΕΣ

ΚΩΔΙΚΟΣ	ΣΠΕΙΡΩΜΑ	€	+ ΦΠΑ
PX-003101	6 X 1		
PX-003100	8 X 1		
PX-003110	10 X 1		
PX-003120	12 X 1,5		
PX-003121	12 X 1		
PX-003130	14 X 1,5		
PX-003140	16 X 1,5		
PX-003150	18 X 1,5		

B.S.P.

PX-003151	1/4		
PX-003152	3/8		
PX-003153	1/2		

ΘΗΛΙΕΣ ΜΑΚΡΥΕΣ ΜΕ ΣΩΛΗΝΑ ΚΑΤΑ DIN

ΚΩΔΙΚΟΣ	ΘΗΛΙΑ	ΣΙΔ/ΝΑΣ L - S	ΜΗΚΟΣ mm	€	€
	B.S.P				+ΦΠΑ
ΡΠ-280612	1/4	12	205		
ΡΠ-283845	3/8	12	45		
ΡΠ-281012	3/8	12	200		
ΡΠ-281013	3/8	12	300		
ΡΠ-281014	3/8	12	500		
ΡΠ-281245	1/2	12	45		
ΡΠ-281315	1/2	15	202		

ΦΛΑΝΤΖΩΤΑ 3000 p.s.i



ΙΣΙΑ 3000psi

ΚΩΔΙΚΟΣ	ΦΛΑΝΤΖΑ	ΣΩΛ	ΣΚΕΤΑ	ΚΟΜΠΛΕ	+ ΦΠΑ
ΡΠ-203013	30,2	1\2			
ΡΠ-203413	34				
ΡΠ-203813	38,1				
ΡΠ-203016	30,2	5\8			
ΡΠ-203416	34				
ΡΠ-203816	38,1				
ΡΠ-204416	44,5	3\4			
ΡΠ-203019	30,2				
ΡΠ-203819	38,1				
ΡΠ-204419	44,5	1"			
ΡΠ-205019	50,8				
ΡΠ-203825	38,1				
ΡΠ-204425	44,5	1\4			
ΡΠ-205025	50,8				
ΡΠ-206025	60,3				
ΡΠ-204432	44,5	1\2			
ΡΠ-205032	50,8				
ΡΠ-206032	60,3				
ΡΠ-205038	50,8	2"			
ΡΠ-206038	60,3				
ΡΠ-207138	71,4				
ΡΠ-207150	71,4				
ΡΠ-208450	84,1				



ΑΜΒΛΕΙΕΣ 45° 3000psi

ΚΩΔΙΚΟΣ	ΦΛΑΝΤΖΑ	ΣΩΛ	ΣΚΕΤΑ	ΚΟΜΠΛΕ	+ ΦΠΑ
ΡΠ-213013	30,2	1\2			
ΡΠ-213413	34				
ΡΠ-213813	38,1				
ΡΠ-213016	30,2	5\8			
ΡΠ-213416	34				
ΡΠ-213816	38,1				
ΡΠ-213019	30,2	3\4			
ΡΠ-213819	38,1				
ΡΠ-214419	44,5				
ΡΠ-215019	50,8	1"			
ΡΠ-213825	38,1				
ΡΠ-214425	44,5				
ΡΠ-215025	50,8	1\1\4			
ΡΠ-216025	60,3				
ΡΠ-214432	44,5				
ΡΠ-215032	50,8	1\1\2			
ΡΠ-216032	60,3				
ΡΠ-215038	50,8				
ΡΠ-216038	60,3	2"			
ΡΠ-217138	71,4				
ΡΠ-217150	71,4				
ΡΠ-218450	84,1				



ΓΩΝΙΕΣ 90° 3000psi

ΚΩΔΙΚΟΣ	ΦΛΑΝΤΖΑ	ΣΩΛ	ΣΚΕΤΑ	ΚΟΜΠΛΕ	+ ΦΠΑ
ΡΠ-223013	30,2	1\2			
ΡΠ-223413	34				
ΡΠ-223813	38,1				
ΡΠ-223016	30,2	5\8			
ΡΠ-223416	34				
ΡΠ-223816	38,1				
ΡΠ-224416	44,5	3\4			
ΡΠ-223019	30,2				
ΡΠ-223819	38,1				
ΡΠ-224419	44,5	1"			
ΡΠ-225019	50,8				
ΡΠ-223825	38,1				
ΡΠ-224425	44,5	1\1\4			
ΡΠ-225025	50,8				
ΡΠ-226025	60,3				
ΡΠ-224432	44,5	1\1\2			
ΡΠ-225032	50,8				
ΡΠ-226032	60,3				
ΡΠ-225038	50,8	2"			
ΡΠ-226038	60,3				
ΡΠ-227138	71,4				
ΡΠ-227150	71,4				
ΡΠ-228450	84,1				

ΑΜΒΛΕΙΕΣ 22,5° 3000psi

ΚΩΔΙΚΟΣ	ΦΛΑΝΤΖΑ	ΣΩΛ	ΣΚΕΤΑ	ΚΟΜΠΛΕ	+ ΦΠΑ
ΡΠ-733819	38,1	3\4			
ΡΠ-734419	44,5				
ΡΠ-734425	44,5	1"			
ΡΠ-735025	50,8				
ΡΠ-735032	50,8	1\1\4			
ΡΠ-736032	60,3				
ΡΠ-736038	60,3	1\1\2			
ΡΠ-737150	71,4				

ΑΜΒΛΕΙΕΣ 30° 3000psi

ΚΩΔΙΚΟΣ	ΦΛΑΝΤΖΑ	ΣΩΛ	ΣΚΕΤΑ	ΚΟΜΠΛΕ	+ ΦΠΑ
ΡΠ-743819	38,1	3\4			
ΡΠ-744419	44,5				
ΡΠ-744425	44,5	1"			
ΡΠ-745025	50,8				
ΡΠ-745032	50,8	1\1\4			
ΡΠ-746032	60,3				
ΡΠ-745038	50,8	1\1\2			
ΡΠ-746038	60,3				
ΡΠ-747150	71,4	2"			

ΑΜΒΛΕΙΕΣ 60° 3000psi

ΚΩΔΙΚΟΣ	ΦΛΑΝΤΖΑ	ΣΩΛ	ΣΚΕΤΑ	ΚΟΜΠΛΕ	+ ΦΠΑ
ΡΠ-753819	38,1	3\4			
ΡΠ-754419	44,5				
ΡΠ-754425	44,5	1"			
ΡΠ-755025	50,8				
ΡΠ-755032	50,8	1\1\4			
ΡΠ-756032	60,3				
ΡΠ-756038	60,3	1\1\2			
ΡΠ-757150	71,4				

☐ ρακόρ ίδιο με σειρά 60

ΦΛΑΝΤΖΩΤΑ 6000 p.s.i



ΙΣΙΑ 6000psi

ΚΩΔΙΚΟΣ	ΦΛΑΝ	ΣΩΛ	πάχος	ΣΚΕΤΑ	ΚΟΜΠΛΕ	+ ΦΠΑ
ΡΠ-203113	31,7	1\2	8			
ΡΠ-204113	41,3		9,5			
ΡΠ-203116	31,7	5\8	8			
ΡΠ-204116	41,3		9,5			
ΡΠ-204816	47,6					
ΡΠ-203119	31,7	3\4	8			
ΡΠ-204119	41,3		9,5			
ΡΠ-204819	47,6					
ΡΠ-204125	41,3	1"	9,5			
ΡΠ-204825	47,6		10,3			
ΡΠ-205425	54					
ΡΠ-204832	47,6	1\4	9,5			
ΡΠ-205432	54		10,3			
ΡΠ-206332	63,5		12,7			
ΡΠ-205438	54	1\2				
ΡΠ-206338	63,5		12,7			
ΡΠ-208038	79,4					
ΡΠ-208050	79,4	2"	12,7			

ΑΜΒΛΕΙΕΣ 45° 6000psi

ΚΩΔΙΚΟΣ	ΦΛΑΝ	ΣΩΛ	πάχος	ΣΚΕΤΑ	ΚΟΜΠΛΕ	+ ΦΠΑ
ΡΠ-213113	31,7	1\2	8			
ΡΠ-214113	41,3		9,5			
ΡΠ-213116	31,7	5\8	8			
ΡΠ-214116	41,3		9,5			
ΡΠ-214816	47,6					
ΡΠ-213119	31,7	3\4	8			
ΡΠ-214118	41,3		9,5			
ΡΠ-214819	47,6					
ΡΠ-214125	41,3	1"	9,5			
ΡΠ-214825	47,6		10,3			
ΡΠ-215425	54					
ΡΠ-214832	47,6	1\4	9,5			
ΡΠ-215432	54		10,3			
ΡΠ-216332	63,5		12,7			
ΡΠ-215438	54	1\2				
ΡΠ-216338	63,5		12,7			
ΡΠ-217938	79,4					
ΡΠ-218050	79,4	2"	12,7			



ΓΩΝΙΕΣ 90° 6000psi

ΚΩΔΙΚΟΣ	ΦΛΑΝ	ΣΩΛ	πάχος	ΣΚΕΤΑ	ΚΟΜΠΛΕ	+ ΦΠΑ
ΡΠ-223113	31,7	1\2	8			
ΡΠ-224113	41,3		9,5			
ΡΠ-223116	31,7	5\8	8			
ΡΠ-224116	41,3		9,5			
ΡΠ-224816	47,6					
ΡΠ-223119	31,7	3\4	8			
ΡΠ-224118	41,3		9,5			
ΡΠ-224819	47,6					
ΡΠ-224125	41,3	1"	9,5			
ΡΠ-224825	47,6		10,3			
ΡΠ-225425	54					
ΡΠ-224832	47,6	1\4	9,5			
ΡΠ-225432	54		10,3			
ΡΠ-226332	63,5		12,7			
ΡΠ-225438	54	1\2				
ΡΠ-226338	63,5		12,7			
ΡΠ-227938	79,4					
ΡΠ-228050	79,4	2"	12,7			

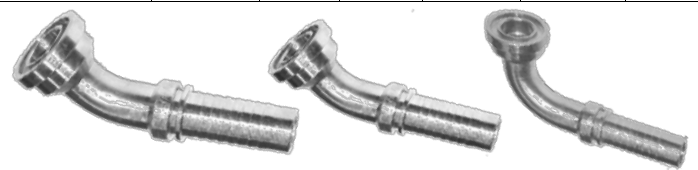

ΑΜΒΛΕΙΕΣ 22,5° 6000psi

ΚΩΔΙΚΟΣ	ΦΛΑΝ	ΣΩΛ	πάχος	ΣΚΕΤΑ	ΚΟΜΠΛΕ	+ ΦΠΑ
ΡΠ-764819	47,6	3\4	9,5			
ΡΠ-764825	47,6	1"	9,5			
ΡΠ-765425	54		10,3			
ΡΠ-765432	54	1\4	10,3			
ΡΠ-766332	63,5		12,7			
ΡΠ-766338	63,5	1\2	12,7			

ΑΜΒΛΕΙΕΣ 30° 6000psi

ΚΩΔΙΚΟΣ	ΦΛΑΝ	ΣΩΛ	πάχος	ΣΚΕΤΑ	ΚΟΜΠΛΕ	+ ΦΠΑ
ΡΠ-774819	47,6	3\4	9,5			
ΡΠ-774825	47,6	1"	9,5			
ΡΠ-775425	54		10,3			
ΡΠ-775432	54	1\4	10,3			
ΡΠ-776332	63,5		12,7			
ΡΠ-776338	63,5	1\2	12,7			

ΑΜΒΛΕΙΕΣ 67° 6000psi

ΚΩΔΙΚΟΣ	ΦΛΑΝ	ΣΩΛ	πάχος	ΣΚΕΤΑ	ΚΟΜΠΛΕ	+ ΦΠΑ
ΡΠ-784819	47,6	3\4	9,5			
ΡΠ-784825	47,6	1"	9,5			
ΡΠ-785425	54		10,3			
ΡΠ-785432	54	1\4	10,3			
ΡΠ-786332	63,5		12,7			
ΡΠ-786338	63,5	1\2	12,7			



ΦΛΑΝΤΖΕΣ LIEBHERR

ΚΩΔΙΚΟΣ	ΦΛΑΝΤΖΑ	ΜΟΙΡΕΣ-ΜΗΚΟΣ	ΣΚΕΤΑ	ΚΟΜΠΛΕ	+ ΦΠΑ
ΡΠ-214119	41,3-3/4	30ο-L90mm			
ΡΠ-214120	41,3-3/4	45ο-L90mm			
ΡΠ-224119	41,3-3/4	90ο-L90mm			

■ ρακόρ ίδιο με σειρά 60

ΦΛΑΝΤΖΩΤΑ 6000 p.s.i SUPERCAT 14mm



**ΙΣΙΑ 6000psi
14mm supercat**



**45° 6000psi
14mm supercat**

ΚΩΔΙΚΟΣ	ΦΛΑΝΤΖΑ	ΣΩΛ	πάχος	ΣΚΕΤΑ	ΚΟΜΠΛΕ	+ ΦΠΑ
ΡΠ-604119	41,3	3/4	14			
ΡΠ-604819	47,6		14			
ΡΠ-604825	47,6	1"	14			
ΡΠ-605425	54		14			
ΡΠ-605432	54	1" 1/4	14			
ΡΠ-606332	63,5		14			
ΡΠ-605438	54	1" 1/2	14			
ΡΠ-606338	63,5		14			

ΚΩΔΙΚΟΣ	ΦΛΑΝΤΖΑ	ΣΩΛ	πάχος	ΣΚΕΤΑ	ΚΟΜΠΛΕ	+ ΦΠΑ
ΡΠ-614119	41,3	3/4	14			
ΡΠ-614819	47,6		14			
ΡΠ-614825	47,6	1"	14			
ΡΠ-615425	54		14			
ΡΠ-615432	54	1" 1/4	14			
ΡΠ-616332	63,5		14			
ΡΠ-615438	54	1" 1/2	14			
ΡΠ-616338	63,5		14			



**90° 6000psi
14mm supercat**



ΚΩΔΙΚΟΣ	ΦΛΑΝΤΖΑ	ΣΩΛ	πάχος	ΣΚΕΤΑ	ΚΟΜΠΛΕ	+ ΦΠΑ
ΡΠ-624119	41,3	3/4	14			
ΡΠ-624819	47,6		14			
ΡΠ-624825	47,6	1"	14			
ΡΠ-625425	54		14			
ΡΠ-625432	54	1" 1/4	14			
ΡΠ-626332	63,5		14			
ΡΠ-625438	54	1" 1/2	14			
ΡΠ-626338	63,5		14			

22,5° 6000psi 14mm supercat						
ΡΠ-794819	47,6	3/4	14			
ΡΠ-794825	47,6	1"	14			
ΡΠ-795425	54		14			
ΡΠ-795432	54	1" 1/4	14			
ΡΠ-796332	63,5		14			
ΡΠ-796338	63,5	1" 1/2	14			

30° 6000psi 14mm supercat						
ΡΠ-804819	47,6	3/4	14			
ΡΠ-804825	47,6	1"	14			
ΡΠ-805425	54		14			
ΡΠ-805432	54	1" 1/4	14			
ΡΠ-806332	63,5		14			
ΡΠ-806338	63,5	1" 1/2	14			

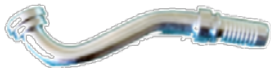

**ΓΩΝΙΑ McCORMIC
ΣΠΑΣΤΗ 3000psi**

ΡΠ-360001	44,5	1"				
-----------	------	----	--	--	--	--



**ΓΩΝΙΑ McCORMIC
120° 3000psi**

ΡΠ-360003	38,1	3/4	120°			
ΡΠ-360004	44,5	1"	120°			



120° 6000psi

ΡΠ-360007	41,3	3/4	120°			
-----------	------	-----	------	--	--	--

67° 6000psi 14mm supercat						
ΡΠ-814119	41,3	3/4	14			
ΡΠ-814819	47,6		14			
ΡΠ-814825	47,6	1"	14			
ΡΠ-815425	54		14			
ΡΠ-815432	54	1" 1/4	14			
ΡΠ-816332	63,5		14			
ΡΠ-816338	63,5	1" 1/2	14			

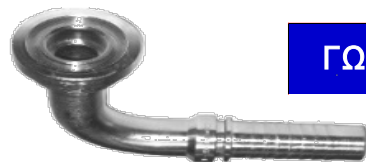

ΓΩΝΙΕΣ ΜΑΚΡΙΕΣ 3000psi



ΓΩΝΙΕΣ ΜΑΚΡΙΕΣ 6000psi

ΚΩΔΙΚΟΣ	ΦΛΑΝΤΖΑ	ΣΩΛΗΝΑ	L mm	ΣΚΕΤΑ	ΚΟΜΠΛΕ	+ ΦΠΑ
ΡΠ-363819	38,1	3/4	L 100			
ΡΠ-363821	38,1		L 120			
ΡΠ-363820	38,1		L 125			
ΡΠ-364419	44,5	1"	L 110			
ΡΠ-364424	44,5		L 100			
ΡΠ-364425	44,5		L 120			
ΡΠ-365025	50,8	1" 1/4	L 120			
ΡΠ-365032	50,8		L 130			

ΚΩΔΙΚΟΣ	ΦΛΑΝΤΖΑ ΜΗΚΟΣ Lmm	ΣΚΕΤΑ	ΚΟΜΠΛΕ	+ ΦΠΑ
ΡΠ-364119	41,3-3/4	L120		
ΡΠ-364120	41,3-3/4	L150		
ΡΠ-364819	47,6-3/4	L90		
ΡΠ-364820	47,6-3/4	L100		
ΡΠ-364125	41,3-1"	L120		
ΡΠ-364825	47,6-1"	L120		
ΡΠ-365425	54-1"	L140		
ΡΠ-365432	54-1" 1/4	L120		



ΚΟΥΖΙΝΕΤΟ Ο/R ΙΣΙΟ - B.S.P.

ΚΟΥΖΙΝΕΤΟ ΚΟΝΤΡΑ ΙΣΙΟ- B.S.P.

ΤΑΠΕΣ ΦΛΑΝΤΖΩΝ

3000 p.s.i

3000 p.s.i

ΚΩΔΙΚΟΣ ΦΛΑΝΤΖΑ € + ΦΠΑ

ΡΠ-352038	38,1-3/4		
ΡΠ-352044	44,5-1"		
ΡΠ-352050	50,8-1½		
ΡΠ-352060	60,3-1½		
ΡΠ-352071	71,4-2"		

ΡΠ-352238	38,1-3/4		
ΡΠ-352244	44,5-1"		
ΡΠ-352250	50,8-1½		
ΡΠ-352260	60,3-1½		
ΡΠ-352271	71,4-2"		

ΡΠ-351030	30,2		
ΡΠ-351038	38,1		
ΡΠ-351044	44,5		
ΡΠ-351050	50,8		
ΡΠ-351060	60,3		
ΡΠ-351032	31,7		
ΡΠ-351041	41,3		
ΡΠ-351048	47,6		
ΡΠ-351054	54		
ΡΠ-351063	63,5		

6000 p.s.i

6000 p.s.i

ΡΠ-352041	41,3-3/4		
ΡΠ-352048	47,6-1"		
ΡΠ-352054	54-1½		
ΡΠ-352063	63,5-1½		
ΡΠ-352079	79-2"		

ΡΠ-352241	41,3-3/4		
ΡΠ-352248	47,6-1"		
ΡΠ-352254	54-1½		
ΡΠ-352263	63,5-1½		
ΡΠ-352279	79-2"		

ΚΟΥΖΙΝΕΤΟ Ο/R ΓΩΝΙΑ - B.S.P.

ΚΟΥΖΙΝΕΤΟ ΚΟΝΤΡΑ ΓΩΝΙΑ - B.S.P.

ΛΑΣΤΙΚΑ Ο/R ΦΛΑΝΤΖΩΝ

ΡΠ-352138	38,1-3/4		
ΡΠ-352144	44,5-1"		
ΡΠ-352150	50,8-1½		
ΡΠ-352160	60,3-1½		
ΡΠ-352171	71,4-2"		

ΡΠ-352338	38,1-3/4		
ΡΠ-352344	44,5-1"		
ΡΠ-352350	50,8-1½		
ΡΠ-352360	60,3-1½		
ΡΠ-352371	71,4-2"		



Στρογγυλά
Σκληρό υλικό για πιέσεις

6000 p.s.i

6000 p.s.i

ΚΩΔΙΚΟΣ ΦΛΑΝΤΖΑ € + ΦΠΑ

ΡΠ-352141	41,3-3/4		
ΡΠ-352148	47,6-1"		
ΡΠ-352154	54-1½		
ΡΠ-352163	63,5-1½		
ΡΠ-352179	79-2"		

ΡΠ-352341	41,3-3/4		
ΡΠ-352348	47,6-1"		
ΡΠ-352354	54-1½		
ΡΠ-352363	63,5-1½		
ΡΠ-352379	79-2"		

ΡΠ-350001	30,2 - 31,7		
ΡΠ-350000	34		
ΡΠ-350002	38,1 - 41,3		
ΡΠ-350003	44,5 - 47,6		
ΡΠ-350004	50,8 - 54		
ΡΠ-350005	60,3 - 63,5		
ΡΠ-350020	71,4 - 79,4		



ΛΑΣΤΙΚΑ ΦΛΑΝΤΖΩΝ ΠΛΑΚΕ πράσινα

ΚΟΥΖΙΝΕΤΑ 3000psi

ΚΩΔΙΚΟΣ	ΦΛΑΝΤΖΑ	€	+ ΦΠΑ
ΡΠ-350030	30,2		
ΡΠ-350038	38,1		
ΡΠ-350044	44,5		
ΡΠ-350050	50,8		
ΡΠ-350060	60,3		
ΡΠ-350071	71,4		
ΡΠ-350084	84,1		



SUPERCAT

ΚΟΥΖΙΝΕΤΑ 6000psi L 14mm

ΚΩΔΙΚΟΣ	ΦΛΑΝΤΖΑ	€	+ ΦΠΑ
ΡΠ-350032	31,7		
ΡΠ-350041	41,3		
ΡΠ-350048	47,6		
ΡΠ-350054	54		
ΡΠ-350063	63,5		
ΡΠ-350079	79		

ΡΠ-350141	41,3		
ΡΠ-350148	47,6		
ΡΠ-350154	54		
ΡΠ-350163	63,5		

ΡΠ-350010	38,1 - 41,3		
ΡΠ-350015	34		
ΡΠ-350011	44,5 - 47,6		
ΡΠ-350012	50,8 - 54		
ΡΠ-350013	60,3 - 63,5		
ΡΠ-350014	71,4 - 79,4		



ΛΑΣΤΙΚΑ φλαντζών ΠΛΑΚΕ μαύρα

ΡΠ-350006	41,3		
ΡΠ-350007	47,6		
ΡΠ-350008	54		
ΡΠ-350009	63,5		

ΡΑΚΟΡ ΑΜΕΡΙΚΗΣ U. N. F. (74° JIC)



ΑΡΣΕΝΙΚΑ U.N.F

ΚΩΔΙΚΟΣ	ΣΠΕΙΡΩΜΑ	ΣΩΛΗΝΑ	ΣΚΕΤΑ	ΚΟΜΠΛΕ	+ ΦΠΑ
ΡΠ-231105	7\16	3\16			
ΡΠ-231106	7\16	1\4			
ΡΠ-231306	1\2X20				
ΡΠ-231406	9\16	5\16			
ΡΠ-231108	7\16				
ΡΠ-231308	1\2X20				
ΡΠ-231408	9\16				
ΡΠ-231608	5\8X18				
ΡΠ-231410	9\16		3\8		
ΡΠ-231610	5\8X18				
ΡΠ-231910	3\4X16				
ΡΠ-232210	7\8	1\2			
ΡΠ-231913	3\4X16				
ΡΠ-232213	7\8	5\8			
ΡΠ-232713	1"1\16				
ΡΠ-232216	7\8				
ΡΠ-232716	1"1\16	3\4			
ΡΠ-232719	1"1\16				
ΡΠ-233019	1"3\16	1"			
ΡΠ-233319	1"5\16				
ΡΠ-232725	1"1\16				
ΡΠ-233025	1"3\16				
ΡΠ-233325	1"5\16	1" 1\4			
ΡΠ-234125	1"5\8				
ΡΠ-234132	1"5\8				
ΡΠ-234732	1"7\8	1" 1\2			
ΡΠ-234738	1"7\8				

ΘΗΛΥΚΑ U.N.F

ΚΩΔΙΚΟΣ	ΣΠΕΙΡΩΜΑ	ΣΩΛΗΝΑ	ΣΚΕΤΑ	ΚΟΜΠΛΕ	+ ΦΠΑ
ΡΠ-240905	3\8X24	3/16			
ΡΠ-241105	7\16				
ΡΠ-241305	1\2X20				
ΡΠ-241106	7\16	1\4			
ΡΠ-241306	1\2X20				
ΡΠ-241406	9\16				
ΡΠ-241108	7\16	5\16			
ΡΠ-241308	1\2X20				
ΡΠ-241408	9\16				
ΡΠ-241608	5\8X18	3\8			
ΡΠ-241410	9\16				
ΡΠ-241610	5\8X18				
ΡΠ-241910	3\4X16	1\2			
ΡΠ-242210	7\8				
ΡΠ-241913	3\4X16	5\8			
ΡΠ-242213	7\8				
ΡΠ-242713	1"1\16				
ΡΠ-242216	7\8	3\4			
ΡΠ-242716	1"1\16				
ΡΠ-242219	7\8	1" 4SH			
ΡΠ-242719	1"1\16				
ΡΠ-243019	1"3\16				
ΡΠ-243319	1"5\16	1" 1\4			
ΡΠ-242725	1"1\16				
ΡΠ-243025	1"3\16	1" 1\2			
ΡΠ-243325	1"5\16				
ΡΠ-244125	1"5\8	2"			
ΡΠ-244132	1"5\8				
ΡΠ-244732	1"7\8				
ΡΠ-244738	1"7\8				
ΡΠ-246338	2"½				
ΡΠ-246350	2"½				



ΑΡΣΕΝΙΚΑ U.N.F ΙΣΙΑ ΕΔΡΑ

ΚΩΔΙΚΟΣ	ΣΠΕΙΡΩΜΑ	ΣΩΛΗΝΑ	ΣΚΕΤΑ	ΚΟΜΠΛΕ	+ ΦΠΑ
ΡΠ-231911	3\4X16	3\8			
ΡΠ-232214	7\8	1\2			

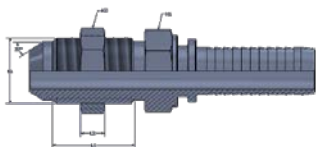

ΑΡΣΕΝΙΚΑ U.N.F ΚΟΝΤΡΑ

ΚΩΔΙΚΟΣ	ΣΠΕΙΡΩΜΑ	ΣΩΛΗΝΑ	ΣΚΕΤΑ	ΚΟΜΠΛΕ	+ ΦΠΑ
ΡΠ-231910K	3\4X16	3\8			
ΡΠ-231913K	3\4X16	1\2			
ΡΠ-232213K	7\8				
ΡΠ-232719K	1"1\16	3\4			

ΡΑΚΟΡ ΑΜΕΡΙΚΗΣ U. N. F. (74° JIC)



ΓΩΝΙΕΣ U.N.F 90°



ΚΩΔΙΚΟΣ	ΣΠΕΙΡΩΜΑ	ΣΩΛΗΝΑ	ΣΚΕΤΑ	ΚΟΜΠΛΕ	+ ΦΠΑ
ΡΠ-250905	3\8X24				
ΡΠ-251105	7\16	3/16			
ΡΠ-251305	1\2X20				
ΡΠ-251106	7\16				
ΡΠ-251306	1\2X20	1\4			
ΡΠ-251406	9\16				
ΡΠ-251108	7\16				
ΡΠ-251308	1\2X20	5\16			
ΡΠ-251408	9\16				
ΡΠ-251608	5\8X18				
ΡΠ-251410	9\16				
ΡΠ-251610	5\8X18	3\8			
ΡΠ-251910	3\4X16				
ΡΠ-252210	7\8				
ΡΠ-251913	3\4X16				
ΡΠ-252213	7\8	1\2			
ΡΠ-252713	1"1\16				
ΡΠ-252216	7\8	5\8			
ΡΠ-252716	1"1\16				
ΡΠ-252219	7\8				
ΡΠ-252719	1"1\16	3\4			
ΡΠ-253019	1"3\16				
ΡΠ-253319	1"5\16				
ΡΠ-253325	1"5\16	1"			
ΡΠ-254125	1" 5\8				
ΡΠ-254132	1" 5\8	1" 1\4			
ΡΠ-254732	1"7\8				
ΡΠ-254738	1"7\8	1" 1\2			
ΡΠ-256350	2"1\2	2"			



ΓΩΝΙΕΣ U.N.F 90° ΜΑΚΡΥΕΣ

ΚΩΔΙΚΟΣ	ΣΠΕΙΡΩΜΑ	ΣΩΛΗΝΑ	ΜΗΚΟΣ	ΣΚΕΤΑ	ΚΟΜΠΛΕ	+ ΦΠΑ
ΡΠ-251107	7\16		L 75			
ΡΠ-251307	1\2X20	1\4	L 75			
ΡΠ-251407	9\16		L 75			
ΡΠ-251411	9\16		L 75			
ΡΠ-251911	3\4X16	3\8	L 75			
ΡΠ-251917	3\4X16		L 90			
ΡΠ-251914	3\4X16	1\2	L 75			
ΡΠ-252214	7\8		L 75			
ΡΠ-252217	7\8	5\8	L 75			
ΡΠ-252720	1"1\16	3\4	L 75			
ΡΠ-253320	1"5\16	1"	L 120			

ΑΜΒΛΙΕΣ U.N.F 45°

ΚΩΔΙΚΟΣ	ΣΠΕΙΡΩΜΑ	ΣΩΛΗΝ	ΣΚΕΤΑ	ΚΟΜΠΛΕ	+ ΦΠΑ
ΡΠ-261105	7\16	3/16			
ΡΠ-261106	7\16				
ΡΠ-261306	1\2X20	1\4			
ΡΠ-261406	9\16				
ΡΠ-261408	9\16	5\16			
ΡΠ-261608	5\8X18				
ΡΠ-261410	9\16				
ΡΠ-261610	5\8X18	3\8			
ΡΠ-261910	3\4X16				
ΡΠ-261913	3\4X16	1\2			
ΡΠ-262213	7\8				
ΡΠ-262216	7\8	5\8			
ΡΠ-262716	1 "1\16				
ΡΠ-262719	1"1\16				
ΡΠ-263019	1"3\16	3\4			
ΡΠ-263319	1"5\16				
ΡΠ-263325	1" 5\16	1"			
ΡΠ-264132	1" 5\8	1"1\4			
ΡΠ-264738	1 "7\8	1"1\2			

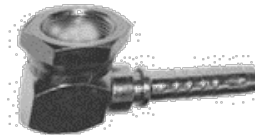

ΓΩΝΙΕΣ COMPACT UNF

ΚΩΔΙΚΟΣ	ΣΠΕΙΡΩΜΑ	ΣΩΛΗΝ	ΣΚΕΤΑ	ΚΟΜΠΛΕ	+ ΦΠΑ
ΡΠ-251109	7\16				
ΡΠ-251310	1\2X20	1\4			
ΡΠ-251413	9\16				
ΡΠ-251414	9\16	5\16			
ΡΠ-251415	9\16				
ΡΠ-251915	3\4X16	3\8			
ΡΠ-251916	3\4X16				
ΡΠ-252215	7\8	1\2			



ΘΗΛΥΚΑ O.R.F.S.

ΚΩΔΙΚΟΣ	ΣΠΕΙΡΩΜΑ	ΣΩΛΗΝΑ	ΣΚΕΤΑ	ΚΟΜΠΛΕ	+ ΦΠΑ
ΡΠ-391406	9\16	1\4			
ΡΠ-391706	11\16				
ΡΠ-391408	9\16	5\16			
ΡΠ-391708	11\16				
ΡΠ-391710	11\16	3\8			
ΡΠ-392010	13\16				
ΡΠ-392013	13\16	1\2			
ΡΠ-392513	1"				
ΡΠ-393013	1" 3\16	5\8			
ΡΠ-392516	1"				
ΡΠ-393016	1" 3\16	3\4			
ΡΠ-393019	1" 3\16				
ΡΠ-393719	1"7\16	1"			
ΡΠ-393725	1"7\16				
ΡΠ-394225	1"11\16	1"1\4			
ΡΠ-394232	1"11\16				
ΡΠ-395038	2"☐	1"1\2			



ΑΜΒΛΕΙΕΣ O.R.F.S.

ΚΩΔΙΚΟΣ	ΣΠΕΙΡΩΜΑ	ΣΩΛΗΝΑ	ΣΚΕΤΑ	ΚΟΜΠΛΕ	+ ΦΠΑ
ΡΠ-401406	9\16	1\4			
ΡΠ-401706	11\16				
ΡΠ-401408	9\16	5\16			
ΡΠ-401708	11\16				
ΡΠ-401710	11\16	3\8			
ΡΠ-402010	13\16				
ΡΠ-402013	13\16	1\2			
ΡΠ-402513	1"				
ΡΠ-403013	1" 3\16	5\8			
ΡΠ-402516	1"				
ΡΠ-403016	1" 3\16	3\4			
ΡΠ-403019	1" 3\16				
ΡΠ-403719	1"7\16	1"			
ΡΠ-403725	1"7\16				
ΡΠ-404225	1"11\16	1"1\4			
ΡΠ-404232	1"11\16				
ΡΠ-405038	2"☐	1"1\2			

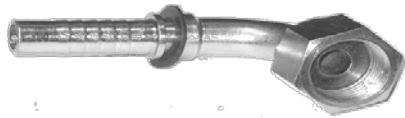

ΓΩΝΙΕΣ O.R.F.S.

ΚΩΔΙΚΟΣ	ΣΠΕΙΡΩΜΑ	ΣΩΛΗΝΑ	ΣΚΕΤΑ	ΚΟΜΠΛΕ	+ ΦΠΑ
ΡΠ-411406	9\16	1\4			
ΡΠ-411706	11\16				
ΡΠ-411408	9\16	5\16			
ΡΠ-411708	11\16				
ΡΠ-411710	11\16	3\8			
ΡΠ-412010	13\16				
ΡΠ-412013	13\16	1\2			
ΡΠ-412513	1"				
ΡΠ-413013	1" 3\16	5\8			
ΡΠ-412516	1"				
ΡΠ-413016	1" 3\16	3\4			
ΡΠ-413019	1" 3\16				
ΡΠ-413719	1"7\16	1"			
ΡΠ-413725	1"7\16				
ΡΠ-414225	1"11\16	1"1\4			
ΡΠ-414232	1"11\16				
ΡΠ-415038	2"☐	1"1\2			



ΑΡΣΕΝΙΚΑ O.R.F.S.

ΚΩΔΙΚΟΣ	ΣΠΕΙΡΩΜΑ	ΣΩΛΗΝΑ	ΣΚΕΤΑ	ΚΟΜΠΛΕ	+ ΦΠΑ
ΡΠ-421406	9\16	1\4			
ΡΠ-421706	11\16				
ΡΠ-421408	9\16	5\16			
ΡΠ-421708	11\16				
ΡΠ-421710	11\16	3\8			
ΡΠ-422010	13\16				
ΡΠ-422013	13\16	1\2			
ΡΠ-422513	1"				
ΡΠ-423013	1" 3\16	5\8			
ΡΠ-422516	1"				
ΡΠ-423016	1" 3\16	3\4			
ΡΠ-423019	1" 3\16				
ΡΠ-423719	1"7\16	1"			
ΡΠ-423725	1"7\16				
ΡΠ-424225	1"11\16☐	1"1\4			
ΡΠ-424232	1"11\16				
ΡΠ-425038	2"☐	1"1\2			

☐ ρακόρ ίδιο με σειρά 60



ΟΡ O.R.F.S.

ΚΩΔΙΚΟΣ	ΣΠΕΙΡΩΜΑ	ΣΩΛΗΝΑ	ΣΚΕΤΑ	ΚΟΜΠΛΕ	+ ΦΠΑ
ΡΠ-420014	9\16				
ΡΠ-420017	11\16				
ΡΠ-420020	13\16				
ΡΠ-420025	1" X 14				
ΡΠ-420030	1" 3\16				
ΡΠ-420037	1"7\16				
ΡΠ-420042	1"11\16				

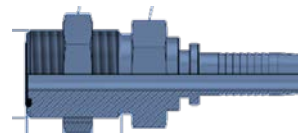

ΑΡΣΕΝΙΚΑ ORFS ΚΟΝΤΡΑ

ΚΩΔΙΚΟΣ	ΣΠΕΙΡΩΜΑ	ΣΩΛΗΝΑ	ΣΚΕΤΑ	ΚΟΜΠΛΕ	+ ΦΠΑ
ΡΠ-421710K	11\16	3\8			
ΡΠ-422013K	13\16 X 16	1\2			
ΡΠ-422516K	1" X 14	5\8			

ΓΩΝΙΕΣ 120°

ΡΠ-363719	1"7\16X12	3\4			
-----------	-----------	-----	--	--	--



ΘΗΛΥΚΑ komatsu

ΓΩΝΙΕΣ O.R.F.S. ΜΑΚΡΥΕΣ

ΚΩΔΙΚΟΣ	ΣΠΕΙΡΩΜΑ	ΣΩΛΗΝΑ	ΣΚΕΤΑ	ΚΟΜΠΛΕ	+ ΦΠΑ
ΡΠ-411407	9\16-1/4	L75			
ΡΠ-411711	11\16-3/8	L75			
ΡΠ-411712	11\16-3/8	L90			
ΡΠ-412011	13\16-3/8	L75			
ΡΠ-412014	13\16-1/2	L75			
ΡΠ-412015	13\16-1/2	L90			
ΡΠ-412514	1" -1/2	L75			
ΡΠ-412517	1" -5/8	L75			
ΡΠ-413017	1" 3\16-5/8	L100			
ΡΠ-413020	1" 3\16-3/4	L100			
ΡΠ-413726	1"7\16- 1"	L120			

ΚΩΔΙΚΟΣ	ΣΠΕΙΡΩΜΑ	ΣΩΛΗΝΑ	ΣΚΕΤΑ	ΚΟΜΠΛΕ	+ ΦΠΑ
ΡΠ-321206	12X1,5				
ΡΠ-321406	14X1,5	1\4			
ΡΠ-321606	16X1,5				
ΡΠ-321408	14X1,5				
ΡΠ-321608	16X1,5	5\16			
ΡΠ-321808	18X1,5				
ΡΠ-321410	14X1,5				
ΡΠ-321610	16X1,5	3\8			
ΡΠ-321810	18X1,5				
ΡΠ-322010	20x1,5				
ΡΠ-321813	18X1,5				
ΡΠ-322013	20x1,5	1\2			
ΡΠ-322213	22X1,5				
ΡΠ-322413	24X1,5				
ΡΠ-322216	22X1,5				
ΡΠ-322416	24X1,5	5\8			
ΡΠ-323016	30X1,5				
ΡΠ-323019	30X1,5	3\4			
ΡΠ-323325	33X1,5	1"			
ΡΠ-323632	36X1,5	1" 1\4			
ΡΠ-324238	42X1,5	1" 1\2			

ΡΟCΛΑΙΝ ΦΛΑΝΤΖΕΣ



ΘΗΛΥΚΑ

ΚΩΔΙΚΟΣ	ΦΛΑΝΤΖΑ	ΣΩΛΗΝΑ	ΣΚΕΤΑ	ΚΟΜΠΛΕ	+ ΦΠΑ
ΡΠ-291300	1\2	1\2			
ΡΠ-291600	5\8	5\8			
ΡΠ-291900	3\4	3\4			
ΡΠ-292500	1"	1"			
ΡΠ-293200	1" 1\4	1" 1\4			



ΓΩΝΙΕΣ komatsu

ΚΩΔΙΚΟΣ	ΣΠΕΙΡΩΜΑ	ΣΩΛΗΝΑ	ΣΚΕΤΑ	ΚΟΜΠΛΕ	+ ΦΠΑ
ΡΠ-431406	14X1,5	1\4			
ΡΠ-431606	16X1,5				
ΡΠ-431610	16X1,5	3\8			
ΡΠ-431810	18X1,5				
ΡΠ-432213	22X1,5	1\2			
ΡΠ-432416	24X1,5	5\8			
ΡΠ-433019	30X1,5	3\4			



ΑΡΣΕΝΙΚΟ

ΚΩΔΙΚΟΣ	ΦΛΑΝΤΖΑ	ΣΩΛΗΝΑ	ΣΚΕΤΑ	ΚΟΜΠΛΕ	+ ΦΠΑ
ΡΠ-291301	1\2	1\2			
ΡΠ-291601	5\8	5\8			
ΡΠ-291901	3\4	3\4			
ΡΠ-292501	1"	1"			
ΡΠ-293201	1" 1\4	1" 1\4			



ΑΡΣΕΝΙΚΑ komatsu

ΚΩΔΙΚΟΣ	ΣΠΕΙΡΩΜΑ	ΣΩΛΗΝΑ	ΣΚΕΤΑ	ΚΟΜΠΛΕ	+ ΦΠΑ
ΡΠ-341610	16X1,5				
ΡΠ-341810	18X1,5	3\8			
ΡΠ-342010	20X1,5				
ΡΠ-342013	20X1,5				
ΡΠ-342213	22X1,5	1\2			
ΡΠ-342413	24X1,5				
ΡΠ-342416	24X1,5	5\8			



ΓΩΝΙΑ

ΚΩΔΙΚΟΣ	ΦΛΑΝΤΖΑ	ΣΩΛΗΝΑ	ΣΚΕΤΑ	ΚΟΜΠΛΕ	+ ΦΠΑ
ΡΠ-291302	1\2	1\2			
ΡΠ-291602	5\8	5\8			
ΡΠ-291902	3\4	3\4			
ΡΠ-292502	1"	1"			
ΡΠ-293202	1" 1\4	1" 1\4			



σύνδεσμοι komatsu

ΚΩΔΙΚΟΣ	ΣΠΕΙΡΩΜΑ	ΣΩΛΗΝΑ	ΣΚΕΤΑ	ΚΟΜΠΛΕ	+ ΦΠΑ
ΡΠ-340014	14X1,5				
ΡΠ-340016	16X1,5				
ΡΠ-340018	18X1,5				
ΡΠ-340020	20X1,5				
ΡΠ-340022	22X1,5				
ΡΠ-340024	24X1,5				
ΡΠ-340030	30X1,5				
ΡΠ-340033	33X1,5				



ΤΑΠΕΣ ΑΡΣΕΝΙΚΕΣ Komatsu			
ΚΩΔΙΚΟΣ	ΣΠΕΙΡΩΜΑ	€	+ ΦΠΑ
ΡΠ-320014	14X1,5		
ΡΠ-320016	16X1,5		
ΡΠ-320018	18X1.5		
ΡΠ-320020	20X1.5		
ΡΠ-320022	22X1.5		
ΡΠ-320024	24X1.5		
ΡΠ-320030	30X1.5		
ΡΠ-320033	33X1.5		

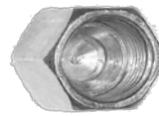

ΤΑΠΕΣ ΘΗΛΥΚΕΣ Komatsu			
ΚΩΔΙΚΟΣ	ΣΠΕΙΡΩΜΑ	€	+ ΦΠΑ
ΡΠ-430014	14X1,5		
ΡΠ-430016	16X1,5		
ΡΠ-430018	18X1.5		
ΡΠ-430022	22X1.5		
ΡΠ-430024	24X1.5		
ΡΠ-430030	30X1.5		
ΡΠ-430033	33X1.5		



ΟΥΡΕΣ ΔΙΠΛΕΣ ΕΝΩΣΕΩΣ

ΚΩΔΙΚΟΣ	ΣΩΛΗΝΑ	ΣΚΕΤΑ	ΚΟΜΠΛΕ	+ ΦΠΑ
ΡΠ-330005	3\16			
ΡΠ-330006	1\4			
ΡΠ-330008	5\16			
ΡΠ-330010	3\8			
ΡΠ-330013	1\2			
ΡΠ-330016	5\8			
ΡΠ-330019	3\4			
ΡΠ-330025	1"			
ΡΠ-330032	1\4			
ΡΠ-330038	1" 1\2			
ΡΠ-330050	2"			



ΟΥΡΕΣ ΚΟΜΗΤΕΣ

ΚΩΔΙΚΟΣ	ΣΩΛΗΝΑ	ΣΚΕΤΑ	ΚΟΜΠΛΕ	+ ΦΠΑ
ΡΠ-300300	1\8			
ΡΠ-300502	3\16			
ΡΠ-300602	1\4			
ΡΠ-300802	5\16			
ΡΠ-301002	3\8			
ΡΠ-301302	1\2			
ΡΠ-301602	5\8			
ΡΠ-301609	5\8 4SH			
ΡΠ-301902	3\4			
ΡΠ-301909	3\4 4SH			
ΡΠ-302502	1" R2			
ΡΠ-302509	1" 4SH			
ΡΠ-303209	1\4 R2-SH			
ΡΠ-303809	1\2 R2-SH			
ΡΠ-305009	2"			

ΡΑΚΟΡ ΜΕ ΘΕΡΜΙΚΗ ΕΠΕΞΕΡΓΑΣΙΑ ΓΙΑ ΥΔΡΑΥΛΙΚΕΣ ΣΦΥΡΕΣ



ΣΦΥΡΙΟΥ Β.Σ.Ρ

ΚΩΔΙΚΟΣ	ΣΠΕΙΡΩΜΑ-ΟΥΡΑ	ΚΟΜΠΛΕ	+ ΦΠΑ
ΡΠ-122526	ΑΡΣ. 1"N.P.T - 1" 4SH		
ΡΠ-132526	ΑΡΣ. 1" BSP - 1" 4SH		
ΡΠ-133226	ΑΡΣ. 1"1/4 BSP - 1" 4SH		
ΡΠ-133233	ΑΡΣ. 1"1/4 BSP - 1\4 4SH		
ΡΠ-101922	ΘΗΛ. 3/4 BSP - 3/4 4SH		
ΡΠ-102527	ΘΗΛ. 1" BSP - 1" 4SH		
ΡΠ-103226	ΘΗΛ. 1"1/4 BSP - 1" 4SH		
ΡΠ-103233	ΘΗΛ. 1"1/4 BSP - 1\4 4SH		



ΣΦΥΡΙΟΥ O.R.F.S

ΚΩΔΙΚΟΣ	ΣΠΕΙΡΩΜΑ	ΣΩΛΗΝΑ	ΚΟΜΠΛΕ	+ ΦΠΑ
ΡΠ-393020	1" 3\16	3\4		
ΡΠ-393726	1"7/16	1"		



πάχος 12,7

ΣΦΥΡΙΟΥ ΦΛΑΝΤΖΕΣ 6000psi

ΚΩΔΙΚΟΣ	ΦΛΑΝ	ΣΩΛ	ΚΟΜΠΛΕ	+ ΦΠΑ
ΡΠ-205426	54	1"		
ΡΠ-205433	54	1\4		

ΣΦΥΡΙΟΥ 6000psi 14mm supercat

ΡΠ-605433	54	1"1\4		
ΡΠ-606339	63,5	1"1\2		



ΣΦΥΡΙΟΥ UNF

ΚΩΔΙΚΟΣ	ΣΠΕΙΡΩΜΑ	ΣΩΛΗΝΑ	ΚΟΜΠΛΕ	+ ΦΠΑ
ΡΠ-244126	1"5\8	1"		
ΡΠ-244133	1"5\8	1"1/4		



συστολές-μαστοί ΣΦΥΡΙΟΥ

Κατασκευή από ενισχυμένο ατσάλι,
βαμμένο για αντοχή στα σφυριά

ΡΠ-133228	ΑΓΓΛΙΑΣ ΑΡΣ 1"1/4-1"			
ΡΣ-Β00322	ΜΑΣΤΟΣ 1"1/4-30Σοκέτος			
ΡΣ-014232	ΜΑΣΤΟΣ 1"1/4-1"5/8			

ΚΥΑΘΙΑ ΠΡΕΣΣΑΡΙΣΤΑ FLEXTUBO italy

(προτεινόμενο πρεσάρισμα με DUNLOP σωλήνα)

ΑΚΑΘΑΡΙΣΤΑ R1T



ΚΩΔΙΚΟΣ	ΕΙΔΟΣ	Φ	πρεσ/μα	€	+ ΦΠΑ
ΡΠ-318005	3\16	19	14,5		
ΡΠ-318006	1\4	20	16,3		
ΡΠ-318008	5\16	22	18,2		
ΡΠ-318010	3\8	24	20,1		
ΡΠ-318013	1\2	28,5	23,7		
ΡΠ-318016	5\8	32	26,9		
ΡΠ-318019	3\4	36	31,5		
ΡΠ-318025	1"	43	38,9		
ΡΠ-318032	1" 1\4	53	48,3		
ΡΠ-318038	1" 1\2	60	53		
ΡΠ-318050	2"	78			

ΑΚΑΘΑΡΙΣΤΑ R2T



ΚΩΔΙΚΟΣ	ΕΙΔΟΣ	Φ	πρεσ/μα	€	+ ΦΠΑ
ΡΠ-319006	1\4	22	17,7		
ΡΠ-319008	5\16	24	20,2		
ΡΠ-319010	3\8	25,5	21,4		
ΡΠ-319013	1\2	30	25,8		
ΡΠ-319016	5\8	34	28,5		
ΡΠ-319019	3\4	38	33,3		
ΡΠ-319025	1"	46	41		

ΚΑΘΑΡΙΣΜΕΝΑ R1



ΚΩΔΙΚΟΣ	ΕΙΔΟΣ	Φ	πρεσ/μα	€	+ ΦΠΑ
ΡΠ-313201	1" 1\4	52	46,5		
ΡΠ-313801	1" 1\2	58	53		
ΡΠ-315001	2"	70	66,3		

ΚΑΘΑΡΙΣΜΕΝΑ R2



ΚΩΔΙΚΟΣ	ΕΙΔΟΣ	Φ	πρεσ/μα	€	+ ΦΠΑ
ΡΠ-310602	1\4	21	17,3		
ΡΠ-310802	5\16	22	18,7		
ΡΠ-311002	3\8	25	21,8		
ΡΠ-311302	1\2	28	24,7		
ΡΠ-311602	5\8	32	27,6		
ΡΠ-311902	3\4	36	32,3		
ΡΠ-312502	1"	45	41,2		
ΡΠ-313202	1" 1\4	56	50,5		
ΡΠ-313803	1" 1\2	62	57		
ΡΠ-315003	2"	75	69,5		

4SP - 4SH

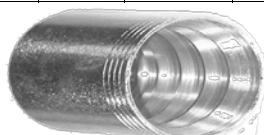

ΡΠ-310609	1\4 4SP	23	18,7		
ΡΠ-311009	3\8 4SP	25,5	23		
ΡΠ-311309	1\2 4SP	30	26,9		
ΡΠ-311609	5\8 4SP	34	30,2		
ΡΠ-311610	5\8 4SP μακρύ	35	32		
ΡΠ-311909	3\4 4SH	38	34,1		
ΡΠ-312509	1" 4SH	46	41,5		
ΡΠ-313205	1" 1\4 4SH	52	48		
ΡΠ-313204	1" 1\4 4SH	55	50		
ΡΠ-313805	1" 1\2 4SH	62	58		
ΡΠ-315010	2" 4SH	75	70,5		

4SP - 4SH



ΓΙΑ ΚΟΝΤΗ ΟΥΡΑ

ΡΠ-3116BP	5\8 κοντό	34	30,2		
ΡΠ-3119BP	3\4 κοντό	38	34,1		
ΡΠ-3125BP	1" κοντό	46	41,5		

R 7-R8- ΜΤΗ1

για θερμοπλαστική



ΚΩΔΙΚΟΣ	ΕΙΔΟΣ	Φ	R7-ΜΤΗ1	€	+ ΦΠΑ
ΡΠ-317003	1\8	11			
ΡΠ-317532	5\32	12			
ΡΠ-317005	3\16	13			
ΡΠ-317004	3\16 ΜΤΗ1	15			
ΡΠ-317006	1\4	17			
ΡΠ-317008	5\16	19			
ΡΠ-317010	3\8	21			
ΡΠ-317013	1\2	25,5			
ΡΠ-317016	5\8	28,5			
ΡΠ-317019	3\4	32			
ΡΠ-317025	1"	40			

TEFLON 1 Σύρμα απλό



ΚΩΔΙΚΟΣ	ΕΙΔΟΣ	Φ	€	+ ΦΠΑ
ΚΤ-310003	1\8	10		
ΚΤ-310005	3\16	12		
ΚΤ-310006	1\4	15		
ΚΤ-310008	5\16	18		
ΚΤ-310010	3\8	20		
ΚΤ-310013	1\2	25		
ΚΤ-310016	5\8	29		
ΚΤ-310019	3\4	31		
ΚΤ-310025	1"			



Τα κυάθια είναι κατασκευασμένα από μολυβδόχο. Επεξεργάζονται θερμικά (ξεπύρωμα) για σωστό πρεσάρισμα (χωρίς σπασίματα), και λιγότερη φθορά σε σωλήνες και πρέσες.

ΚΥΑΘΙΑ ΠΡΕΣΣΑΡΙΣΤΑ ΕΥΡΩΠΑΙΚΑ (ISO 9001)



R4
ΑΝΑΡΡΟΦΗΣΕΩΣ



ΤΕΦΛΟΝ ΣΠΙΡΑΛ ΕΛΙΚΟΕΙΔΕΣ

ΚΩΔΙΚΟΣ	ΕΙΔΟΣ	Φ	πρεσ/μα	€	+ ΦΠΑ
KT-31ΣΠ13	1\2	25	20,7		
KT-31ΣΠ16	5\8	28	24		
KT-31ΣΠ19	3\4	33	28,7		
KT-31ΣΠ25	1"	39	35,4		

ΚΩΔΙΚΟΣ	ΕΙΔΟΣ	ΕΞΩΤ.	ΕΣΩΤ.	€	+ ΦΠΑ
ΡΠ-310450	2"	73	65		
ΡΠ-310463	2"½	88	79		
ΡΠ-310475	3"	100	93		

ΠΛΥΝΤΗΡΙΟΥ 5/16
COMPACT 400bar/160°C



ΡΠ-3108ΠΛ	5\16	21	18,5		
-----------	------	----	------	--	--

INTERLOCK 4SH

A/C πρέσσας BARRIER

ΚΩΔΙΚΟΣ	ΕΙΔΟΣ	Φ	πρεσ/μα	€	+ ΦΠΑ
AK-310008	5\16	22			
AK-310010	3\8	28			
AK-310013	1\2	28,5			
AK-310016	5\8	32			

ΚΩΔΙΚΟΣ	ΕΙΔΟΣ	Φ	πρεσ/μα	€	+ ΦΠΑ
ΡΠ-314013	1\2				
ΡΠ-314019	3\4	38	34		
ΡΠ-314025	1"	46	42		
ΡΠ-314032	1"1\4	55	51		
ΡΠ-314038	1"1\2	62	58		
ΡΠ-314050	2"	78,5	74		

A/C πρέσσας REDUCED

AK-312008	5\16	22	18,5		
AK-312010	3\8	24	21,3		
AK-312013	1\2	25,5	22,5		
AK-312016	5\8	30	26		

INTERLOCK 6SP R15

ΚΩΔΙΚΟΣ	ΕΙΔΟΣ	Φ	πρεσ/μα	€	+ ΦΠΑ
ΡΠ-316032	1"1\4	60	54		
ΡΠ-316038	1"1\2	67	61		
ΡΠ-316050	2"	84,5	78		

ΡΑΚΟΡ ΜΙCΡΟΤΥΒΙ ΜΕΤΡΗΣΗΣ ΠΙΕΣΗΣ



Θηλυκά Βαλβίδας I.S.M

ΚΩΔΙΚΟΣ	ΠΕΡΙΓΡΑΦΗ	€	ΚΟΜΠΛΕ
MT-000003	ΘΗΛΥΚΟ 16X2		
MT-000004	ΘΗΛΥΚΟ 16X1,5		



ΒΙΣΜΑ bayonet

ΚΩΔΙΚΟΣ	ΒΙΣΜΑ	€	ΚΟΜΠΛΕ
MT-000012	ΒΙΣΜΑ		



Θηλυκά B.S.P.

MT-000029	ΘΗΛΥΚΟ1/8		
MT-000023	ΘΗΛΥΚΟ1/4		
MT-000002	ΘΗΛΥΚΟ 1/4O/R		

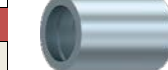

ΚΥΑΘΙΟ ΜΙCΡΟΤΥΒΙ

MT-000001	ΚΥΑΘΙΟ Μ/ΤΥΒΙ		
-----------	---------------	--	--



Γωνίες B.S.P.

MT-000035	1/4 BSP		
MT-000038	1/4O/R		



ΤΑΠΑ ΜΙCΡΟΤΥΒΙ

MT-000014	ΤΑΠΑ ΜΙCΡΟ		
-----------	------------	--	--



Θηλυκά Μετρικά

MT-000005	12X1,5 6L		
MT-000006	14X1,5 8L		
MT-000037	14X1,5 6S		
MT-000036	16X1,5 8S		



€ ΚΟΜΠΛΕ



R.Z. Μετρικά

MT-000024	RZ 6L-S		
MT-000025	RZ 8L-S		

MT-000039	ΘΗΛΙΑ Μ/ΤΥΒΙ Φ10		
-----------	------------------	--	--

Θηλυκά U.N.F.

MT-000030	7/16X20		
MT-000031	1/2X20		
MT-000032	9/16X18		



ΣΩΛΗΝ ΟΛ TEST ΜΙCΡΟΤΥΒΙ 630 bar

ΚΩΔΙΚΟΣ	ΕΣΩΤ.	ΕΞΩΤ.	€	+ ΦΠΑ
MT-000033	11/16orfs			
MT-000034	13/16orfs			
MT-000000	2,1	5,1		

ΠΑΚΟΡ INTERLOCK 4SH - R15 (ΚΑΘΑΡΙΣΜΑ ΜΕΣΑ ΕΞΩ)

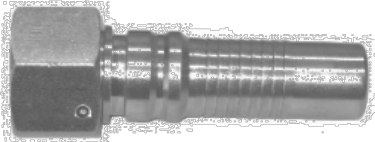

**INTERLOCK
ΘΗΛΥΚΑ B.S.P.**

ΚΩΔΙΚΟΣ	ΣΠΕΙΡΩΜΑ	ΣΩΛΗΝΑ	€	+ ΦΠΑ
ΡΠ-901313	1/2	1/2		
ΡΠ-901919	3/4	3/4		
ΡΠ-902525	1"	1"		
ΡΠ-903232	1" 1/4	1" 1/4		
ΡΠ-903838	1" 1/2	1" 1/2		
ΡΠ-905050	2"	2"		

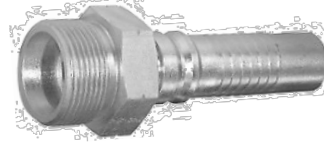

**INTERLOCK
ΑΡΣΕΝΙΚΑ B.S.P.**

ΚΩΔΙΚΟΣ	ΣΠΕΙΡΩΜΑ	ΣΩΛΗΝΑ	€	+ ΦΠΑ
ΡΠ-921313	1/2	1/2		
ΡΠ-921919	3/4	3/4		
ΡΠ-922525	1"	1"		
ΡΠ-923232	1" 1/4	1" 1/4		
ΡΠ-923838	1" 1/2	1" 1/2		
ΡΠ-925050	2"	2"		



**INTERLOCK
ΓΩΝΙΕΣ B.S.P.**

ΚΩΔΙΚΟΣ	ΣΠΕΙΡΩΜΑ	ΣΩΛΗΝΑ	€	+ ΦΠΑ
ΡΠ-911313	1/2	1/2		
ΡΠ-911919	3/4	3/4		
ΡΠ-912525	1"	1"		
ΡΠ-913232	1" 1/4	1" 1/4		
ΡΠ-913838	1" 1/2	1" 1/2		
ΡΠ-915050	2"	2"		



**INTERLOCK
ΘΗΛΥΚΑ ΜΕΤΡΙΚΑ**

ΚΩΔΙΚΟΣ	ΣΠΕΙΡΩΜΑ	ΣΩΛΗΝΑ	€	+ ΦΠΑ
ΡΠ-703022	20S(30X2)	3/4		
ΡΠ-703619	25S (36X2)			
ΡΠ-703625	25S (36X2)	1"		
ΡΠ-704225	30S(42X2)			
ΡΠ-704232	30S(42X2)	1"1/4		
ΡΠ-705232	38S(52X2)			
ΡΠ-705238	38S(52X2)	1" 1/2		



**INTERLOCK
ΑΡΣΕΝΙΚΑ ΜΕΤΡΙΚΑ**

ΚΩΔΙΚΟΣ	ΣΠΕΙΡΩΜΑ	ΣΩΛΗΝΑ	€	+ ΦΠΑ
ΡΠ-693022	20S(30X2)	3/4		
ΡΠ-693619	25S (36X2)			
ΡΠ-693625	25S (36X2)	1"		
ΡΠ-694225	30S(42X2)			
ΡΠ-695232	38S(52X2)	1"1/4		
ΡΠ-695238	38S(52X2)	1" 1/2		



**INTERLOCK
ΓΩΝΙΕΣ ΜΕΤΡΙΚΕΣ**

ΚΩΔΙΚΟΣ	ΣΠΕΙΡΩΜΑ	ΣΩΛΗΝΑ	€	+ ΦΠΑ
ΡΠ-713022	20S(30X2)	3/4		
ΡΠ-713619	25S (36X2)			
ΡΠ-713625	25S (36X2)	1"		
ΡΠ-714225	30S(42X2)			
ΡΠ-715232	38S(52X2)	1"1/4		
ΡΠ-715238	38S(52X2)	1" 1/2		

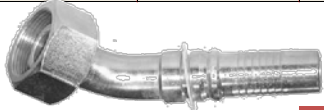

**INTERLOCK
ΑΜΒΛΙΕΣ ΜΕΤΡΙΚΕΣ**

ΚΩΔΙΚΟΣ	ΣΠΕΙΡΩΜΑ	ΣΩΛΗΝΑ	€	+ ΦΠΑ
ΡΠ-723022	20S(30X2)	3/4		
ΡΠ-723619	25S (36X2)			
ΡΠ-723625	25S (36X2)	1"		
ΡΠ-724225	30S(42X2)			
ΡΠ-725232	38S(52X2)	1"1/4		
ΡΠ-725238	38S(52X2)	1" 1/2		



**INTERLOCK
ΘΗΛΥΚΑ U.N.F**

ΚΩΔΙΚΟΣ	ΣΠΕΙΡΩΜΑ	ΣΩΛΗΝΑ	€	+ ΦΠΑ
ΡΠ-952719	1"1\16	3/4		
ΡΠ-953325	1"5\16	1"		
ΡΠ-954132	1"5\8	1" 1/4		
ΡΠ-954738	1"7\8	1" 1/2		
ΡΠ-956350	2"1\2	2"		

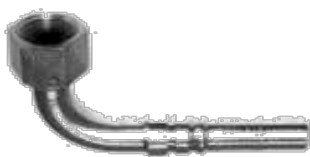

**INTERLOCK
ΓΩΝΙΕΣ U.N.F**

ΚΩΔΙΚΟΣ	ΣΠΕΙΡΩΜΑ	ΣΩΛΗΝΑ	ΣΚΕΤΑ	+ ΦΠΑ
ΡΠ-962719	1"1\16	3/4		
ΡΠ-963325	1"5\16	1"		
ΡΠ-964132	1"5\8	1"1/4		
ΡΠ-964738	1"7\8	1"1/2		
ΡΠ-966350	2"1\2	2"		



**INTERLOCK
ΘΗΛΥΚΑ O.R.F.S.**

ΚΩΔΙΚΟΣ	ΣΠΕΙΡΩΜΑ	ΣΩΛΗΝΑ	ΣΚΕΤΑ	+ ΦΠΑ
ΡΠ-973019	1" 3\16	3/4		
ΡΠ-973725	1"7\16	1"		
ΡΠ-974232	1"11\16	1"1/4		
ΡΠ-975038	2"X12	1"1/2		

ΠΑΚΟΡ INTERLOCK 4SH - R15 (ΚΑΘΑΡΙΣΜΑ ΜΕΣΑ ΕΞΩ)



INTERLOCK

ΑΜΒΛΙΕΣ O.R.F.S.

ΚΩΔΙΚΟΣ	ΣΠΕΙΡΩΜΑ	ΣΩΛΗΝ	ΣΚΕΤΑ	+ ΦΠΑ
ΡΠ-993019	1" 3/16	3/4		
ΡΠ-993725	1"7/16	1"		
ΡΠ-994232	1"11/16	1"1/4		
ΡΠ-995038	2"X12	1"1/2		



INTERLOCK

ΓΩΝΙΕΣ O.R.F.S.

ΚΩΔΙΚΟΣ	ΣΠΕΙΡΩΜΑ	ΣΩΛΗΝ	ΣΚΕΤΑ	+ ΦΠΑ
ΡΠ-983019	1" 3/16	3/4		
ΡΠ-983725	1"7/16	1"		
ΡΠ-984232	1"11/16	1"1/4		
ΡΠ-985038	2"X12	1"1/2		



Interlock

ΙΣΙΟ 3000psi

ΚΩΔΙΚΟΣ	ΦΛΑΝΤΖΑ	ΣΩΛ	€	+ ΦΠΑ
ΡΠ-873819	38,1	3/4		
ΡΠ-874419	44,5			
ΡΠ-874425	44,5	1"		
ΡΠ-875025	50,8			
ΡΠ-875032	50,8	1"1/4		
ΡΠ-876032	60,3			
ΡΠ-876038	60,3	1"1/2		
ΡΠ-877138	71,4			
ΡΠ-877150	71,4	2"		



Interlock

ΑΜΒΛΕΙΑ45ο 3000psi

ΚΩΔΙΚΟΣ	ΦΛΑΝΤΖΑ	ΣΩΛ	€	+ ΦΠΑ
ΡΠ-883819	38,1	3/4		
ΡΠ-884419	44,5			
ΡΠ-884425	44,5	1"		
ΡΠ-885025	50,8			
ΡΠ-885032	50,8	1"1/4		
ΡΠ-886032	60,3			
ΡΠ-886038	60,3	1"1/2		
ΡΠ-887138	71,4			
ΡΠ-887150	71,4	2"		

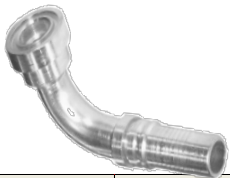

Interlock

ΓΩΝΙΑ 90ο 3000psi

ΚΩΔΙΚΟΣ	ΦΛΑΝΤΖΑ	ΣΩΛ	€	+ ΦΠΑ
ΡΠ-893819	38,1	3/4		
ΡΠ-894419	44,5			
ΡΠ-894425	44,5	1"		
ΡΠ-895025	50,8			
ΡΠ-895032	50,8	1"1/4		
ΡΠ-896032	60,3			
ΡΠ-896038	60,3	1"1/2		
ΡΠ-897138	71,4			
ΡΠ-897150	71,4	2"		



3000psi interlock

ΓΩΝΙΕΣ ΜΑΚΡΥΞΕΣ

ΚΩΔΙΚΟΣ	ΦΛΑΝΤΖΑ	ΜΗΚΟΣ	€	+ ΦΠΑ
ΡΠ-897200	38,1-3/4	L 130		
ΡΠ-897201	38,1-3/4	L 150		
ΡΠ-897202	44,5-3/4	L 130		
ΡΠ-897203	44,5-3/4	L 150		
ΡΠ-897204	44,5-1"	L 100		
ΡΠ-897205	44,5-1"	L 130		
ΡΠ-897206	44,5-1"	L 150		
ΡΠ-897207	50,8-1"	L 100		
ΡΠ-897208	50,8-1"	L 130		
ΡΠ-897209	50,8-1 1/4	L 130		



Interlock

ΙΣΙΟ 6000psi

ΚΩΔΙΚΟΣ	ΦΛΑΝΤΖΑ	ΣΩΛ	πάχος	€	+ ΦΠΑ
ΡΠ-634119	41,3	3/4	9,5		
ΡΠ-634719	47,6		9,5		
ΡΠ-634125	41,3		9,5		
ΡΠ-634825	47,6	1"	9,5		
ΡΠ-635425	54		10,5		
ΡΠ-634832	47,6	1 1/4	9,5		
ΡΠ-635432	54		10,5		
ΡΠ-636332	63,5		12,7		
ΡΠ-635438	54	1 1/2	12,7		
ΡΠ-636338	63,5		12,7		
ΡΠ-637938	79,4		12,7		
ΡΠ-637950	79,4	2"	12,7		



Interlock6000psi

ΑΜΒΛΕΙΑ45ο

ΚΩΔΙΚΟΣ	ΦΛΑΝΤΖΑ	πάχος	€	+ ΦΠΑ
ΡΠ-644119	41,3-3/4	9,5		
ΡΠ-644719	47,6-3/4	9,5		
ΡΠ-644125	41,3-1"	9,5		
ΡΠ-644825	47,6-1"	9,5		
ΡΠ-645425	54-1"	10,5		
ΡΠ-644832	47,6-1 1/4	9,5		
ΡΠ-645432	54-1 1/4	10,5		
ΡΠ-646332	63,5-1 1/4	12,7		
ΡΠ-645438	54-1 1/2	10,5		
ΡΠ-646338	63,5-1 1/2	12,7		
ΡΠ-647938	79,4-1 1/2	12,7		
ΡΠ-647950	79,4-2"	12,7		

ΠΑΚΟΡ INTERLOCK 4SH - R15 (ΚΑΘΑΡΙΣΜΑ ΜΕΣΑ ΕΞΩ)



**ΓΩΝΙΑ 90ο
6000psi
Interlock**

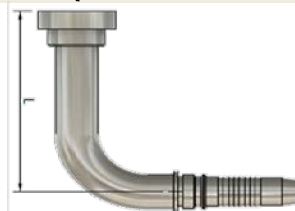

ΚΩΔΙΚΟΣ	ΦΛΑΝΤΖΑ	ΣΩΛ	πάχος	€	+ ΦΠΑ
ΡΠ-654119	41,3	3/4	9,5		
ΡΠ-654719	47,6		9,5		
ΡΠ-654125	41,3	1"	9,5		
ΡΠ-654825	47,6		9,5		
ΡΠ-655425	54	1 1/4	10,5		
ΡΠ-654832	47,6		10,5		
ΡΠ-655432	54	1 1/2	10,5		
ΡΠ-656332	63,5		12,7		
ΡΠ-655438	54	2"	12,7		
ΡΠ-656338	63,5		12,7		
ΡΠ-657938	79,4				
ΡΠ-657950	79,4				

**ΓΩΝΙΕΣ 90° ΜΑΚΡΥΕΣ
INTERLOCK 6000psi**

ΚΩΔΙΚΟΣ	ΜΗΚΟΣ	ΦΛΑΝΤΖΑ	ΣΩΛ	πάχος	€	+ ΦΠΑ
ΡΠ-897220	L 120	31,7	3/4	9,5		
ΡΠ-824118	L 90	41,3				
ΡΠ-897221	L 100	41,3				
ΡΠ-897222	L 130	41,3				
ΡΠ-834119	L 150	41,3				
ΡΠ-668055	L 170	41,3				
ΡΠ-824719	L 90	47,6				
ΡΠ-897223	L 100	47,6				
ΡΠ-897224	L 120	47,6	1"	10,50		
ΡΠ-824824	L 90	47,6				
ΡΠ-824825	L 120	47,6				
ΡΠ-824826	L 130	47,6				
ΡΠ-834825	L 150	47,6				
ΡΠ-668057	L 190	47,6				
ΡΠ-668060	L 260	47,6				
ΡΠ-897225	L 100	54				



ΑΜΒΛΕΙΕΣ 22,5° 6000psi interlock

ΚΩΔΙΚΟΣ	ΦΛΑΝΤΖΑ	ΣΩΛΗΝΑ	πάχος	€	+ ΦΠΑ
ΡΠ-658001	41,3	3/4	9,5		
ΡΠ-658002	47,6		9,5		
ΡΠ-658003	41,3	1"	9,5		
ΡΠ-658004	47,6		9,5		
ΡΠ-658005	54	1 1/4	10,5		
ΡΠ-658006	54		10,5		
ΡΠ-658007	63,5	1 1/2	12,7		
ΡΠ-658008	63,5		12,7		

ΡΠ-825425	L 120	54	1"1/4	10,5		
ΡΠ-897226	L 130	54				
ΡΠ-835425	L 150	54				
ΡΠ-845432	L 140	54				
ΡΠ-897228	L 150	54				
ΡΠ-897229	L 165	54				
ΡΠ-668059	L 190	54				
ΡΠ-897230	L 210	54				
ΡΠ-846332	L 140	63,5		12,7		

ΑΜΒΛΕΙΕΣ 30° 6000psi interlock

ΚΩΔΙΚΟΣ	ΦΛΑΝΤΖΑ	ΣΩΛΗΝ	πάχος	€	+ ΦΠΑ
ΡΠ-658010	41,3	3/4	9,5		
ΡΠ-658011	47,6		9,5		
ΡΠ-658012	41,3	1"	9,5		
ΡΠ-658013	47,6		9,5		
ΡΠ-658014	54	1 1/4	10,5		
ΡΠ-658015	54		10,5		
ΡΠ-658016	63,5	1 1/2	12,7		
ΡΠ-658017	63,5		12,7		



**ΑΜΒΛΕΙΑ 45ο
ΜΑΚΡΥ ΣΤΕΛΕΧΟΣ**

6000psi interlock

ΚΩΔΙΚΟΣ	ΦΛΑΝΤΖΑ	ΣΩΛΗΝ	πάχος	€	+ ΦΠΑ
ΡΠ-658054	41,3	3/4	9,5		
ΡΠ-658055	47,6		9,5		
ΡΠ-658057	47,6	1"	9,5		
ΡΠ-658058	54		10,5		
ΡΠ-658059	54	1 1/4	10,5		
ΡΠ-658060	63,5		12,7		
ΡΠ-658061	63,5	1 1/2	12,7		

ΑΜΒΛΕΙΕΣ 60° 6000psi interlock

ΚΩΔΙΚΟΣ	ΦΛΑΝΤΖΑ	ΣΩΛΗΝ	πάχος	€	+ ΦΠΑ
ΡΠ-658019	41,3	3/4	9,5		
ΡΠ-658020	47,6		9,5		
ΡΠ-658021	41,3	1"	9,5		
ΡΠ-658022	47,6		9,5		
ΡΠ-658023	54	1 1/4	10,5		
ΡΠ-658024	54		10,5		
ΡΠ-658025	63,5	1 1/2	12,7		
ΡΠ-658026	63,5		12,7		



110°-120°-135°

6000 psi INTERLOCK

ΚΩΔΙΚΟΣ	ΦΛΑΝΤΖΑ	ΣΩΛΗΝ	ΜΟΙΡΕΣ	πάχος	€	+ ΦΠΑ
ΡΠ-897250	54-1 1/4	L90	110°	10,5		
ΡΠ-360002	47,6	1"	120°	9,5		
ΡΠ-360006	54	1 1/4	120°	10,5		
ΡΠ-897260	47,6	1"	135°	9,5		
ΡΠ-897261	54	1 1/4	135°	10,5		



ΙΣΙΟ INTERLOCK supercat 14mm

ΚΩΔΙΚΟΣ	ΦΛΑΝΤΖΑ	ΣΩΛΗΝΑ	πάχος	€	+ ΦΠΑ
ΡΠ-664119	41,3	3/4	14mm		
ΡΠ-664719	47,6		14mm		
ΡΠ-664125	41,3	1"	14mm		
ΡΠ-664825	47,6		14mm		
ΡΠ-665425	54		14mm		
ΡΠ-665432	54	1 1/4	14mm		
ΡΠ-666332	63,5		14mm		
ΡΠ-666338	63,5	1 1/2	14mm		



45° INTERLOCK supercat 14mm

ΚΩΔΙΚΟΣ	ΦΛΑΝΤΖΑ	ΣΩΛΗΝΑ	πάχος	€	+ ΦΠΑ
ΡΠ-674119	41,3	3/4	14mm		
ΡΠ-674719	47,6		14mm		
ΡΠ-674125	41,3	1"	14mm		
ΡΠ-674825	47,6		14mm		
ΡΠ-675425	54		14mm		
ΡΠ-675432	54	1 1/4	14mm		
ΡΠ-676332	63,5		14mm		
ΡΠ-676338	63,5	1 1/2	14mm		



90° INTERLOCK supercat 14mm

ΚΩΔΙΚΟΣ	ΦΛΑΝΤΖΑ	ΣΩΛΗΝΑ	πάχος	€	+ ΦΠΑ
ΡΠ-684119	41,3	3/4	14mm		
ΡΠ-684719	47,6		14mm		
ΡΠ-684125	41,3	1"	14mm		
ΡΠ-684825	47,6		14mm		
ΡΠ-685425	54		14mm		
ΡΠ-685432	54	1"1/4	14mm		
ΡΠ-686332	63,5		14mm		
ΡΠ-686338	63,5	1"1/2	14mm		

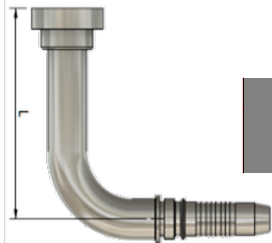

ΓΩΝΙΕΣ ΜΑΚΡΥΕΣ 90° INTERLOCK supercat 14mm

ΚΩΔΙΚΟΣ	ΜΗΚΟΣ	ΦΛΑΝΤΖΑ	ΣΩΛ	€	+ ΦΠΑ
ΡΠ-897235	L 120	41,3	3/4		
ΡΠ-897236	L 100	47,6			
ΡΠ-897237	L 110	47,6	1"		
ΡΠ-897238	L 130	47,6			
ΡΠ-897239	L 125	54			
ΡΠ-897240	L 150	54	1 1/4		



ΑΜΒΛΕΙΕΣ 22,5° 6000psi interlock L 14

ΚΩΔΙΚΟΣ	ΦΛΑΝΤΖΑ	ΣΩΛΗΝΑ	πάχος	€	+ ΦΠΑ
ΡΠ-658028	41,3	3/4	14mm		
ΡΠ-658029	47,6		14mm		
ΡΠ-658030	41,3	1"	14mm		
ΡΠ-658031	47,6		14mm		
ΡΠ-658032	54		14mm		
ΡΠ-658033	54	1 1/4	14mm		
ΡΠ-658034	63,5		14mm		
ΡΠ-658035	63,5	1 1/2	14mm		

ΑΜΒΛΕΙΕΣ 30° 6000psi interlock L14

ΚΩΔΙΚΟΣ	ΦΛΑΝΤΖΑ	ΣΩΛΗΝΑ	πάχος	€	+ ΦΠΑ
ΡΠ-658037	41,3	3/4	14mm		
ΡΠ-658038	47,6		14mm		
ΡΠ-658039	41,3	1"	14mm		
ΡΠ-658040	47,6		14mm		
ΡΠ-658041	54		14mm		
ΡΠ-658042	54	1 1/4	14mm		
ΡΠ-658043	63,5		14mm		
ΡΠ-658044	63,5	1 1/2	14mm		

ΑΜΒΛΕΙΕΣ 60° 6000psi interlock L14

ΚΩΔΙΚΟΣ	ΦΛΑΝΤΖΑ	ΣΩΛΗΝΑ	πάχος	€	+ ΦΠΑ
ΡΠ-658046	41,3	3/4	14mm		
ΡΠ-658047	47,6		14mm		
ΡΠ-658048	41,3	1"	14mm		
ΡΠ-658049	47,6		14mm		
ΡΠ-658050	54		14mm		
ΡΠ-658051	54	1 1/4	14mm		
ΡΠ-658052	63,5		14mm		
ΡΠ-658053	63,5	1 1/2	14mm		



ORESTEIN ΜΕ ΠΛΑΚΑΚΙ ΠΕΡΑΣΤΟ

ΡΠ-925432	ΙΣΙΟ	54	1 1/4		
ΡΠ-935432	45°	54			
ΡΠ-945432	90°	54	1"1/2		
ΡΠ-926338	ΙΣΙΟ	63,5			
ΡΠ-936338	45°	63,5			
ΡΠ-946338	90°	63,5			

Σειρά-80 B.S.P. Cast



ΘΗΛΥΚΑ B.S.P



ΓΩΝΙΕΣ B.S.P

ΚΩΔΙΚΟΣ	ΣΠΕΙΡΩΜΑ	ΟΥΡΑ	€	ΚΟΜΠΛΕ	+ ΦΠΑ
80-100305	1/8	3/16			
80-100605	1/4				
80-100306	1/8	1/4			
80-100606	1/4				
80-101006	3/8				
80-101306	1/2				
80-100608	1/4	5/16			
80-101008	3/8				
80-101308	1/2				
80-100610	1/4	3/8			
80-101010	3/8				
80-101310	1/2				
80-101013	3/8	1/2			
80-101313	1/2				
80-101613	5/8				
80-101912	3/4				
80-101616	5/8	5/8			
80-101916	3/4				
80-101919	3/4	3/4			
80-102519	1"				
80-102525	1"	1"			
80-103225	1"1/4				
80-103232	1"1/4	1"1/4			
80-103838	1"1/2	1"1/2			
80-105050	2"	2"			

ΚΩΔΙΚΟΣ	ΣΠΕΙΡΩΜΑ	ΟΥΡΑ	€	ΚΟΜΠΛΕ	+ ΦΠΑ
80-110305	1/8	3/16			
80-110605	1/4				
80-110306	1/8	1/4			
80-110606	1/4				
80-111006	3/8	5/16			
80-110608	1/4				
80-111008	3/8				
80-110610	1/4	3/8			
80-111010	3/8				
80-111310	1/2	1/2			
80-111013	3/8				
80-111313	1/2				
80-111613	5/8				
80-111913	3/4	5/8			
80-111616	5/8				
80-111916	3/4	3/4			
80-111919	3/4				
80-112519	1"	1"			
80-112525	1"				
80-113225	1"1/4	1"1/4			
80-113232	1"1/4	1"1/4			
80-113838	1"1/2	1"1/2			
80-115050	2"	2"			



ΓΩΝΙΕΣ COMPACT



ΑΜΒΛΙΕΣ 45° B.S.P

ΚΩΔΙΚΟΣ	ΣΠΕΙΡΩΜΑ	ΟΥΡΑ	ΣΚΕΤΑ	ΚΟΜΠΛΕ	+ ΦΠΑ
80-090606	1/4	1/4			
80-091010	3/8	3/8			
80-091313	1/2	1/2			
80-091919	3/4	3/4			
80-092525	1"	1"			

ΚΩΔΙΚΟΣ	ΣΠΕΙΡΩΜΑ	ΟΥΡΑ	€	ΚΟΜΠΛΕ	+ ΦΠΑ
80-140305	1/8	3/16			
80-140605	1/4				
80-140306	1/8	1/4			
80-140606	1/4				
80-141006	3/8	5/16			
80-140608	1/4				
80-141008	3/8				
80-140610	1/4	3/8			
80-141010	3/8				
80-141310	1/2	1/2			
80-141013	3/8				
80-141313	1/2	5/8			
80-141616	5/8				
80-141916	3/4	3/4			
80-141919	3/4				
80-142519	1"	1"			
80-142525	1"				
80-143232	1"1/4	1"1/4			
80-143838	1"1/2	1"1/2			
80-145050	2"	2"			



ΘΗΛΙΕΣ ΠΙΕΣΕΩΣ B.S.P

ΚΩΔΙΚΟΣ	ΣΠΕΙΡΩΜΑ	ΟΥΡΑ	€	ΚΟΜΠΛΕ	+ ΦΠΑ
80-280606	1/4	1/4			
80-281006	3/8				
80-280608	1/4	5/16			
80-281008	3/8				
80-281010	3/8	3/8			
80-281310	1/2				
80-281313	1/2	1/2			
80-281919	3/4	3/4			
80-282525	1"	1"			

ΚΩΔΙΚΟΣ	ΣΠΕΙΡΩΜΑ	ΟΥΡΑ	€	ΚΟΜΠΛΕ	+ ΦΠΑ
80-141013	3/8	1/2			
80-141313	1/2				
80-141616	5/8	5/8			
80-141916	3/4				
80-141919	3/4	3/4			
80-142519	1"				
80-142525	1"	1"			
80-143232	1"1/4	1"1/4			
80-143838	1"1/2	1"1/2			
80-145050	2"	2"			



ΑΡΣΕΝΙΚΑ Ν.Ρ.Τ

ΚΩΔΙΚΟΣ	ΣΠΕΙΡΩΜΑ	ΟΥΡΑ	€	ΚΟΜΠΛΕ	+ ΦΠΑ
80-120606	1\4	1\4			
80-121006	3\8				
80-120608	1\4	5\16			
80-121008	3\8				
80-121010	3\8	3\8			
80-121310	1\2				
80-121013	3\8	1\2			
80-121313	1\2				
80-121916	3\4	5\8			
80-121919	3\4	3\4			
80-122519	1"				
80-122525	1"	1"			



ΑΡΣΕΝΙΚΑ μετρικά ΣΕΙΡΑ L

ΚΩΔΙΚΟΣ	ΣΠΕΙΡΩΜΑ	ΣΩΛΗΝΑΣ	ΕΔΡΑ	€	ΚΟΜΠΛΕ	+ ΦΠΑ
80-151205	12X1,5	3\16	6L			
80-151405	14X1,5		8L			
80-151406	14X1,5	1\4	8L			
80-151606	16X1,5		10L			
80-151806	18X1,5	5\16	12L			
80-151608	16X1,5		10L			
80-151808	18X1,5	3\8	12L			
80-151810	18X1,5		12L			
80-152210	22X1,5	1\2	15L			
80-152213	22X1,5		15L			
80-152613	26X1,5	5\8	18L			
80-152616	26X1,5		18L			
80-153019	30X2	3\4	22L			
80-153625	36X2	1"	28L			
80-154532	45X2	1\4	35L			
80-155238	52X2	1\2	42L			



ΑΡΣΕΝΙΚΑ Β.Σ.Ρ

ΚΩΔΙΚΟΣ	ΣΠΕΙΡΩΜΑ	ΟΥΡΑ	€	ΚΟΜΠΛΕ	+ ΦΠΑ
80-130305	1\8	3\16			
80-130605	1\4				
80-130306	1\8	1\4			
80-130606	1\4				
80-131006	3\8	5\16			
80-131306	1\2				
80-130608	1\4	3\8			
80-131008	3\8				
80-131308	1\2	1\2			
80-130610	1\4				
80-131010	3\8	5\8			
80-131310	1\2				
80-131013	3\8	3\4			
80-131313	1\2				
80-131913	3\4	1"			
80-131616	5\8				
80-131916	3\4	1"			
80-131919	3\4				
80-132519	1"	1"			
80-132525	1"				
80-133232	1"1/4	1"1/4			
80-133838	1"1/2	1"1/2			
80-135050	2"	2"			

ΑΡΣΕΝΙΚΑ ΣΕΙΡΑ S

ΚΩΔΙΚΟΣ	ΣΠΕΙΡΩΜΑ	ΣΩΛΗΝΑΣ	ΕΔΡΑ	€	ΚΟΜΠΛΕ	+ ΦΠΑ
80-150605	14X1,5	3\16	6S			
80-150805	16X1,5		8S			
80-150606	14X1,5	1\4	6S			
80-150806	16X1,5		8S			
80-151006	18X1,5	5\16	10S			
80-152006	20X1,5		12S			
80-151008	18X1,5	3\8	10S			
80-152008	20X1,5		12S			
80-152010	20X1,5	1\2	12S			
80-152211	22X1,5		14S			
80-152214	22X1,5	5\8	14S			
80-152413	24X1,5		16S			
80-153016	30X2	3\4	20S			
80-153022	30X2	1"	20S			
80-153619	36X2		25S			
80-153626	36X2	1"1/4	25S			
80-154225	42X2		30S			
80-155232	52X2		38S			

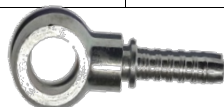

ΘΗΛΙΕΣ μετρικές

ΚΩΔΙΚΟΣ	ΔΙΑΜΕΤΡΟΣ	ΟΥΡΑ	€	ΚΟΜΠΛΕ	+ ΦΠΑ
80-271005	10mm	3\16			
80-271205	12mm				
80-271405	14mm	1\4			
80-271006	10mm				
80-271206	12mm	5\16			
80-271406	14mm				
80-271408	14mm	3\4			
80-271608	16mm				

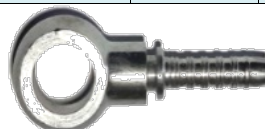

ΚΩΔΙΚΟΣ	ΔΙΑΜΕΤΡΟΣ	ΟΥΡΑ	€	ΚΟΜΠΛΕ	+ ΦΠΑ
80-271410	14mm	3\8			
80-271610	16mm				
80-271810	18mm	1\2			
80-272210	22mm				
80-271813	18mm	5\8			
80-272013	20mm				
80-272213	22mm	3\4			
80-272216	22mm				
80-272616	26mm				
80-272619	26mm				



**ΘΗΛΥΚΑ
ΣΕΙΡΑ L**

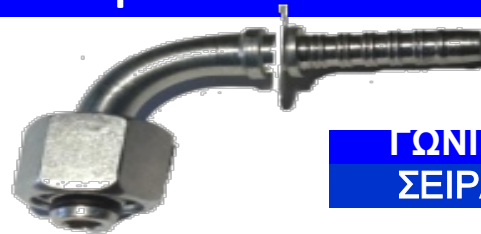

**ΓΩΝΙΕΣ
ΣΕΙΡΑ L**

ΚΩΔΙΚΟΣ	ΣΠΕΙΡΩΜΑ	ΣΩΛΗΝΑ	ΕΔΡΑ	€	ΚΟΜΠΛΕ	+ ΦΠΑ	ΚΩΔΙΚΟΣ	ΣΠΕΙΡΩΜΑ	ΣΩΛΗΝΑ	ΕΔΡΑ	€	ΚΟΜΠΛΕ	+ ΦΠΑ	
80-161205	12X1,5	3\16	6L				80-171205	12X1,5	3\16	6L				
80-161405	14X1,5		8L				80-171405	14X1,5		8L				
80-161406	14X1,5	1\4	8L				80-171406	14X1,5	1\4	8L				
80-161606	16X1,5		10L				80-171606	16X1,5		10L				
80-161806	18X1,5		12L				80-171806	18X1,5		12L				
80-161608	16X1,5	5\16	10L				80-171608	16X1,5	5\16	10L				
80-161808	18X1,5		12L				80-171808	18X1,5		12L				
80-161810	18X1,5	3\8	12L				80-171810	18X1,5	3\8	12L				
80-162210	22X1,5		15L				80-172210	22X1,5		15L				
80-162213	22X1,5	1\2	15L				80-172213	22X1,5	1\2	15L				
80-162613	26X1,5		18L				80-172613	26X1,5		18L				
80-162616	26X1,5	5\8	18L				80-172616	26X1,5	5\8	18L				
80-163019	30X2	3\4	22L				80-173019	30X2	3\4	22L				
80-163625	36X2	1"	28L				80-173625	36X2	1"	28L				
80-164532	45X2	1\4	35L				80-174532	45X2	1\4	35L				
80-165238	52X2	1\2	42L				80-175238	52X2	1\2	42L				



**ΘΗΛΥΚΑ
ΣΕΙΡΑ S**



**ΓΩΝΙΕΣ
ΣΕΙΡΑ S**

ΚΩΔΙΚΟΣ	ΣΠΕΙΡΩΜΑ	ΣΩΛΗΝΑ	ΕΔΡΑ	€	ΚΟΜΠΛΕ	+ ΦΠΑ	ΚΩΔΙΚΟΣ	ΣΠΕΙΡΩΜΑ	ΣΩΛΗΝΑ	ΕΔΡΑ	€	ΚΟΜΠΛΕ	+ ΦΠΑ	
80-160605	14X1,5	3\16	6S				80-170605	14X1,5	3\16	6S				
80-160805	16X1,5		8S				80-170805	16X1,5		8S				
80-160606	14X1,5	1\4	6S				80-170606	14X1,5	1\4	6S				
80-160806	16X1,5		8S				80-170806	16X1,5		8S				
80-161006	18X1,5		10S				80-171006	18X1,5		10S				
80-162006	20X1,5	5\16	12S				80-172006	20X1,5	5\16	12S				
80-161008	18X1,5		10S				80-171008	18X1,5		10S				
80-162008	20X1,5	3\8	12S				80-172008	20X1,5	3\8	12S				
80-162010	20X1,5		14S				80-172010	20X1,5		14S				
80-162211	22X1,5	1\2	14S				80-172211	22X1,5	1\2	14S				
80-162214	22X1,5		16S				80-172214	22X1,5		16S				
80-162413	24X1,5	5\8	20S				80-172413	24X1,5	5\8	20S				
80-163016	30X2		20S				80-173016	30X2		20S				
80-163022	30X2	3\4	25S				80-173022	30X2	3\4	25S				
80-163619	36X2		25S				80-173619	36X2		25S				
80-163626	36X2	1"	30S				80-173626	36X2	1"	30S				
80-164225	42X2		38S				80-174225	42X2		38S				
80-165232	52X2	1\1\4	38S				80-175232	52X2	1\1\4	38S				



ΑΜΒΛΙΕΣ ΣΕΙΡΑ L



ΙΣΙΑ 3000psi

ΚΩΔΙΚΟΣ	ΣΠΕΙΡΩΜΑ	ΣΩΛΗΝΑ	ΕΔΡΑ	€	ΚΟΜΠΛΕ	+ ΦΠΑ	ΚΩΔΙΚΟΣ	ΦΛΑΝΤΖΑ	ΣΩΛΗΝΑ	€	ΚΟΜΠΛΕ	+ ΦΠΑ
							80-203013	30,2	1/2			
80-381205	12X1,5	3/16	6L				80-203813	38,1				
80-381405	14X1,5		8L				80-203816	38,1	5/8			
80-381406	14X1,5	1/4	8L				80-203819	38,1	3/4			
80-381606	16X1,5		10L				80-204419	44,5		1"		
80-381806	18X1,5	5/16	12L				80-204425	44,5	1 1/4			
80-381608	16X1,5		10L				80-205025	50,8		1 1/2		
80-381808	18X1,5	3/8	12L				80-205032	50,8	2"			
80-381810	18X1,5		12L				80-206032	60,3				
80-382210	22X1,5	1/2	15L				80-206038	60,3	1 1/2			
80-382213	22X1,5		15L				80-207138	71,4				
80-382613	26X1,5	5/8	18L				80-207150	71,4				
80-382616	26X1,5		18L									
80-383019	30X2	3/4	22L									
80-383625	36X2	1"	28L									
80-384532	45X2	1 1/4	35L									
80-385238	52X2	1 1/2	42L									



ΑΜΒΛΙΕΣ 45° 3000psi



ΑΜΒΛΙΕΣ ΣΕΙΡΑ S

ΚΩΔΙΚΟΣ	ΣΠΕΙΡΩΜΑ	ΣΩΛΗΝΑ	ΕΔΡΑ	€	ΚΟΜΠΛΕ	+ ΦΠΑ	ΚΩΔΙΚΟΣ	ΦΛΑΝΤΖΑ	ΣΩΛΗΝΑ	€	ΚΟΜΠΛΕ	+ ΦΠΑ
							80-213013	30,2	1/2			
80-380605	14X1,5	3/16	6S				80-213813	38,1				
80-380805	16X1,5		8S				80-213816	38,1	5/8			
80-380606	14X1,5	1/4	6S				80-213819	38,1	3/4			
80-380806	16X1,5		8S				80-214419	44,5		1"		
80-381006	18X1,5	5/16	10S				80-214425	44,5	1 1/4			
80-382006	20X1,5		12S				80-215025	50,8		1 1/2		
80-381008	18X1,5	3/8	10S				80-215032	50,8	2"			
80-382008	20X1,5		12S				80-216032	60,3				
80-382010	20X1,5	1/2	12S				80-216038	60,3	1 1/2			
80-382211	22X1,5		14S				80-217138	71,4				
80-382214	22X1,5	3/4	14S				80-217150	71,4				
80-382413	24X1,5		16S									
80-383016	30X2	5/8	20S									
80-383022	30X2	1"	20S									
80-383619	36X2		25S									
80-383626	36X2	1 1/4	25S									
80-384225	42X2		30S									
80-385232	52X2	1 1/2	38S									



ΓΩΝΙΕΣ 90° 3000psi

ΚΩΔΙΚΟΣ	ΦΛΑΝΤΖΑ	ΣΩΛΗΝΑ	€	ΚΟΜΠΛΕ	+ ΦΠΑ
80-223013	30,2	1/2			
80-223813	38,1				
80-223816	38,1	5/8			
80-223819	38,1	3/4			
80-224419	44,5		1"		
80-224425	44,5	1 1/4			
80-225025	50,8		1 1/2		
80-225032	50,8	2"			
80-226032	60,3				
80-226038	60,3				
80-227138	71,4				
80-227150	71,4				



**6000psi
ΙΣΙΑ**



ΑΡΣΕΝΙΚΑ U.N.F

ΚΩΔΙΚΟΣ	ΦΛΑΝΤΖΑ	ΣΩΛΗΝΑ	€	ΚΟΜΠΛΕ	+ ΦΠΑ	ΚΩΔΙΚΟΣ	ΣΠΕΙΡΩΜΑ	ΣΩΛΗΝ	€	ΚΟΜΠΛΕ	+ ΦΠΑ
80-203113	31,7	1/2				80-231106	7\16	1\4			
80-204113	41,3					80-231306	1\2X20				
80-204116	41,3	5\8				80-231406	9\16	5/16			
80-204119	41,3	3/4				80-231408	9\16				
80-204819	47,6						80-231410	9\16	3\8		
80-204825	47,6	1"				80-231910	3\4X16				
80-205425	54						80-232210	7\8	1\2		
80-205432	54	1\4				80-231913	3\4X16				
80-206332	63,5						80-232213	7\8	5\8		
80-206338	63,5	1\2				80-232713	1"1\16				
80-207938	79,4						80-232216	7\8	3\4		
80-207950	79,4	2"				80-232716	1"1\16				
						80-232719	1"1\16	1"			
						80-233319	1"5\16				
						80-233325	1"5\16				



**6000psi
ΑΜΒΛΙΕΣ 45°**

ΚΩΔΙΚΟΣ	ΦΛΑΝΤΖΑ	ΣΩΛΗΝΑ	€	ΚΟΜΠΛΕ	+ ΦΠΑ
80-213113	31,7	1/2			
80-214113	41,3				
80-214116	41,3	5\8			
80-214119	41,3	3/4			
80-214819	47,6				
80-214825	47,6	1"			
80-215425	54				
80-215432	54	1\4			
80-216332	63,5				
80-216338	63,5	1\2			
80-217938	79,4				
80-217950	79,4	2"			



ΘΗΛΥΚΑ U.N.F

ΚΩΔΙΚΟΣ	ΦΛΑΝΤΖΑ	ΣΩΛΗΝΑ	€	ΚΟΜΠΛΕ	+ ΦΠΑ	ΚΩΔΙΚΟΣ	ΣΠΕΙΡΩΜΑ	ΣΩΛΗΝΑ	€	ΚΟΜΠΛΕ	+ ΦΠΑ
80-241105						80-241105	7\16	3\16			
80-241106						80-241106	7\16	1\4			
80-241306						80-241306	1\2X20				
80-241406						80-241406	9\16	5/16			
80-241408						80-241408	9\16				
80-241410						80-241410	9\16	3\8			
80-241910						80-241910	3\4X16				
80-242210						80-242210	7\8	1\2			
80-241913						80-241913	3\4X16				
80-242213						80-242213	7\8	5\8			
80-242713						80-242713	1"1\16				
80-242216						80-242216	7\8	3\4			
80-242716						80-242716	1"1\16				
80-242719						80-242719	1"1\16	1"			
80-243319						80-243319	1"5\16				
80-243325						80-243325	1"5\16	1"1\4			
80-244125						80-244125	1"5\8				
80-244132						80-244132	1"5\8	1" 1\2			
80-244732						80-244732	1"7\8				
80-244738						80-244738	1"7\8	2"			
80-246350						80-246350	2"1\2				



**ΓΩΝΙΕΣ 90°
6000psi**

ΚΩΔΙΚΟΣ	ΦΛΑΝΤΖΑ	ΣΩΛΗΝΑ	€	ΚΟΜΠΛΕ	+ ΦΠΑ
80-223113	31,7	1/2			
80-224113	41,3				
80-224116	41,3	5\8			
80-224119	41,3	3/4			
80-224819	47,6				
80-224825	47,6	1"			
80-225425	54				
80-225432	54	1\4			
80-226332	63,5				
80-226338	63,5	1\2			
80-227938	79,4				
80-227950	79,4	2"			



ΓΩΝΙΕΣ U.N.F 90°						ΘΗΛΥΚΑ O.R.F.S.						
ΚΩΔΙΚΟΣ	ΣΠΕΙΡΩΜΑ	ΣΩΛΗΝ	€	ΚΟΜΠΛΕ	+ ΦΠΑ	ΚΩΔΙΚΟΣ	ΣΠΕΙΡΩΜΑ	ΣΩΛΗΝ	€	ΚΟΜΠΛΕ	+ ΦΠΑ	
80-251106	7\16	1\4				80-391406	9\16	1\4				
80-251306	1\2X20					80-391706	11\16					
80-251406	9\16					80-391708	11\16		5\16			
80-251408	9\16	5\16				80-391710	11\16	3\8				
80-251410	9\16				80-392010	13\16						
80-251910	3\4X16	3\8				80-392013	13\16					
80-252210	7\8					80-392513	1"	1\2				
80-251913	3\4X16	1\2				80-393013	1" 3\16					
80-252213	7\8					80-392516	1"	5\8				
80-252713	1"1\16					80-393016	1" 3\16					
80-252216	7\8	5\8				80-393019	1" 3\16	3\4				
80-252716	1"1\16					80-393719	1"7\16					
80-252719	1"1\16	3\4				80-393725	1"7\16	1"				
80-253319	1"5\16					80-394232	1"11\16	1"1\4				
80-253325	1"5\16	1"				80-395038	2"X12	1"1\2				
80-254132	1"5\8	1"1\4										
80-254732	1"7\8											
80-254738	1"7\8	1"1\2										
80-256350	2"1\2	2"										



ΑΜΒΛΕΙΕΣ U.N.F 45°						ΓΩΝΙΕΣ O.R.F.S.						
ΚΩΔΙΚΟΣ	ΣΠΕΙΡΩΜΑ	ΣΩΛΗΝ	€	ΚΟΜΠΛΕ	+ ΦΠΑ	ΚΩΔΙΚΟΣ	ΣΠΕΙΡΩΜΑ	ΣΩΛΗΝ	€	ΚΟΜΠΛΕ	+ ΦΠΑ	
80-261106	7\16	1\4				80-411406	9\16	1\4				
80-261306	1\2X20					80-411706	11\16					
80-261406	9\16					80-411708	11\16		5\16			
80-261408	9\16	5\16				80-411710	11\16	3\8				
80-261410	9\16				80-412010	13\16						
80-261910	3\4X16	3\8				80-412013	13\16	1\2				
80-262210	7\8					80-412513	1"					
80-261913	3\4X16	1\2				80-413013	1" 3\16	5\8				
80-262213	7\8					80-412516	1"					
80-262713	1"1\16					80-413016	1" 3\16	3\4				
80-262216	7\8	5\8				80-413019	1" 3\16					
80-262716	1"1\16					80-413719	1"7\16					
80-262719	1"1\16	3\4				80-413725	1"7\16	1"				
80-263319	1"5\16					80-414232	1"11\16	1"1\4				
80-263325	1" 5\16	1"				80-415038	2"X12	1"1\2				
80-264132	1"5\8	1"1\4										
80-264738	1"7\8	1"1\2										



O.R.F.S. ΑΡΣΕΝΙΚΑ



ΘΗΛΥΚΑ ΜΕΤΡΙΚΑ

60° κώνο

ΚΩΔΙΚΟΣ	ΣΠΕΙΡΩΜΑ	ΣΩΛΗΝΑ	€	ΚΟΜΠΛΕ	+ ΦΠΑ
80-421406	9\16				
80-421706	11\16	1\4			
80-421708	11\16	5\16			
80-421710	11\16				
80-422010	13\16	3\8			
80-422013	13\16				
80-422513	1"	1\2			
80-423013	1" 3\16				
80-422516	1"				
80-423016	1" 3\16	5\8			
80-423019	1" 3\16				
80-423719	1"7\16	3\4			
80-423725	1"7\16	1"			
80-424232	1"11\16	1"¼			

ΚΩΔΙΚΟΣ	ΣΠΕΙΡΩΜΑ	ΟΥΡΑ	ΣΚΕΤΑ	ΚΟΜΠΛΕ	+ ΦΠΑ
80-481205	12X1,5	3\16			
80-481206	12X1,5				
80-481406	14X1,5	1\4			
80-481606	16X1,5				
80-481408	14X1,5				
80-481608	16X1,5	5\16			
80-481808	18X1,5				
80-481410	14X1,5				
80-481610	16X1,5				
80-481810	18X1,5	3\8			
80-482010	20X1,5				
80-482210	22X1,5				
80-481813	18X1,5				
80-482013	20X1,5	1\2			
80-482213	22X1,5				
80-482613	26X1,5				
80-482616	26X1,5	5\8			
80-482619	26X1,5	3\4			
80-483019	30X1,5				
80-483825	38X1,5	1"			

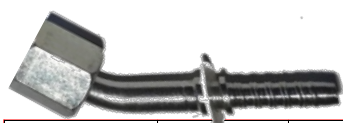

O.R.F.S. ΑΜΒΛΕΙΕΣ

ΚΩΔΙΚΟΣ	ΣΠΕΙΡΩΜΑ	ΣΩΛΗΝΑ	€	ΚΟΜΠΛΕ	+ ΦΠΑ
80-401406	9\16				
80-401706	11\16	1\4			
80-401708	11\16	5\16			
80-401710	11\16				
80-402010	13\16	3\8			
80-402013	13\16				
80-402513	1"	1\2			
80-403013	1" 3\16				
80-402516	1"				
80-403016	1" 3\16	5\8			
80-403019	1" 3\16				
80-403719	1"7\16	3\4			
80-403725	1"7\16	1"			
80-404232	1"11\16	1"¼			



ΓΩΝΙΕΣ ΜΕΤΡΙΚΕΣ 60° κώνο

ΚΩΔΙΚΟΣ	ΣΠΕΙΡΩΜΑ	ΟΥΡΑ	ΣΚΕΤΑ	ΚΟΜΠΛΕ	+ ΦΠΑ
80-451205	12X1,5	3\16			
80-451206	12X1,5				
80-451406	14X1,5	1\4			
80-451606	16X1,5				
80-451408	14X1,5				
80-451608	16X1,5	5\16			
80-451808	18X1,5				
80-451410	14X1,5				
80-451610	16X1,5				
80-451810	18X1,5	3\8			
80-452010	20X1,5				
80-452210	22X1,5				
80-451813	18X1,5				
80-452013	20X1,5	1\2			
80-452213	22X1,5				
80-452613	26X1,5				
80-452616	26X1,5	5\8			
80-452619	26X1,5	3\4			

ΚΩΔΙΚΟΣ	ΣΠΕΙΡΩΜΑ	ΟΥΡΑ	ΣΚΕΤΑ	ΚΟΜΠΛΕ	+ ΦΠΑ
80-471205	12X1,5	3\16			
80-471206	12X1,5				
80-471406	14X1,5	1\4			
80-471606	16X1,5				
80-471408	14X1,5				
80-471608	16X1,5	5\16			
80-471808	18X1,5				
80-471410	14X1,5				
80-471610	16X1,5				
80-471810	18X1,5	3\8			
80-472010	20X1,5				
80-472210	22X1,5				
80-471813	18X1,5				
80-472013	20X1,5	1\2			
80-472213	22X1,5				
80-472613	26X1,5				
80-472616	26X1,5	5\8			
80-472619	26X1,5	3\4			
80-473019	30X1,5				
80-473825	38X1,5	1"			





ΑΚΑΘΑΡΙΣΤΑ R1T

ΚΩΔΙΚΟΣ	ΕΙΔΟΣ	Φ	πρεσ/μα	€	+ ΦΠΑ
80-318005	3/16	18	13,5		
80-318006	1/4	19	15		
80-318008	5/16	21	16,5		
80-318010	3/8	23	19		
80-318013	1/2	27,5	22,8		
80-318016	5/8	31	26,6		
80-318019	3/4	35	30,2		
80-318025	1"	43	38,1		
80-318032	1" 1/4	51	45,8		
80-318038	1" 1/2	58	52,8		



ΚΑΘΑΡΙΣΜΕΝΑ R2

ΚΩΔΙΚΟΣ	ΕΙΔΟΣ	Φ	πρεσ/μα	€	+ ΦΠΑ
80-310602	1/4	20	16,4		
80-310802	5/16	23	19,7		
80-311002	3/8	24,5	20,7		
80-311302	1/2	29	24,9		
80-311602	5/8	33	28		
80-311902	3/4	37	31,5		
80-312502	1"	45	40,5		
80-313202	1" 1/4	55	49		
80-313802	1" 1/2	61	55		
80-315002	2"	74	69,2		



ΑΚΑΘΑΡΙΣΤΑ R2T

ΚΩΔΙΚΟΣ	ΕΙΔΟΣ	Φ	πρεσ/μα	€	+ ΦΠΑ
80-319006	1/4	21	16,6		
80-319008	5/16	23	19		
80-319010	3/8	24,5	20		
80-319013	1/2	28	23,4		
80-319016	5/8	32	27,4		
80-319019	3/4	36	31,2		
80-319025	1"	45	39,5		



4SP - 4SH

ΚΩΔΙΚΟΣ	ΕΙΔΟΣ	Φ	πρεσ/μα	€	+ ΦΠΑ
80-310609	1/4 4SP	22	18,4		
80-311009	3/8 4SP	25	21,6		
80-311309	1/2 4SP	29	25,3		
80-311609	5/8 4SP	33	29,1		
80-311909	3/4 4SH	38	33,8		
80-312509	1" 4SH	45	40,6		
80-313204	1" 1/4 4SH	52	47,3		
80-313804	1" 1/2 4SH	60	55,5		



R 7-R8- MTH1 Για θερμοπλαστική

ΚΩΔΙΚΟΣ	ΕΙΔΟΣ	Φ	πρεσ/μα	€	+ ΦΠΑ
80-317005	3/16	14			
80-317006	1/4	17			
80-317008	5/16	19			
80-317010	3/8	21			
80-317013	1/2	25,5			
80-317016	5/8	28,5			
80-317019	3/4	32			
80-317025	1"	40			

(προτεινόμενο πρεσάρισμα με σωλήνα DUNLOP)

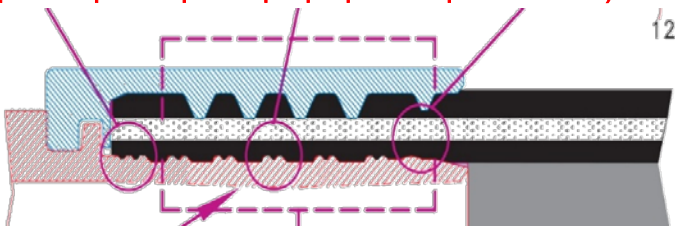

Η εξέλιξη κατασκευής ρακέρ από τον CAST. Προσφέρουν απόλυτη εγγύηση & ασφάλεια. Όταν πρεσάρεται το κυάθιο πιέζει την εξωτερική διάμετρο του σωλήνα με την ουρά του ρακέρ προσφέροντας 12 σημεία στεγανοποίησης, έτσι έχουμε πλήρη εφαρμογή-ασφάλεια

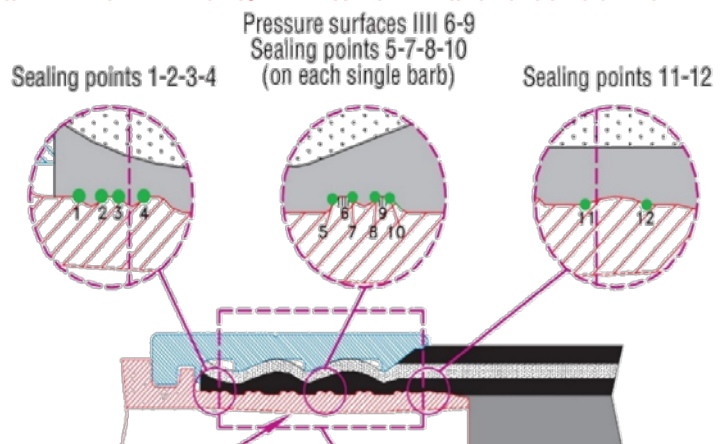

PUSH IN QO LINE

ΡΑΚΟΡ ΑΥΤΟΜΑΤΑ ΥΨΗΛΗΣ ΠΙΕΣΗΣ 350 bar



ΜΑΣΤΟΙ ΑΥΤΟΜΑΤΟΙ QO 350bar ΒΑΣΗΣ

ΚΩΔΙΚΟΣ	ΣΠΕΙΡΩΜΑ	ΔΙΑΜΕΤΡΟΣ	€	+ ΦΠΑ
MK-000006	1/4 BSP	9,70		
MK-000010	3/8 BSP	12,10		
MK-000013	1/2 BSP	16,00		
MK-000019	3/4 BSP	22,90		
ΚΩΔΙΚΟΣ	ΣΠΕΙΡΩΜΑ	ΔΙΑΜΕΤΡΟΣ	€	+ ΦΠΑ
MK-000111	7/16 UNF	9,70		
MK-000114	9/16 UNF	12,10		
MK-000119	3/4X16UNF	16,00		
MK-000127	1-1/16UNF	22,90		
ΚΩΔΙΚΟΣ	ΣΠΕΙΡΩΜΑ	ΔΙΑΜΕΤΡΟΣ	€	+ ΦΠΑ
MK-000214	14X1.5	9,70		
MK-000216	16X1.5	12,10		
MK-000218	18X1.5	16,00		
MK-000222	22X1.5	22,90		



ΡΑΚΟΡ ΙΣΙΟ ΠΡΕΣΣΑΡΙΣΤΟ ΑΥΤΟΜΑΤΟ QO

ΚΩΔΙΚΟΣ	ΣΠΕΙΡΩΜΑ	ΔΙΑΜΕΤΡΟΣ	€	+ ΦΠΑ
MK-000306	1\4	9,70		
MK-000310	3\8	12,10		
MK-000313	1\2	16,00		
MK-000319	3\4	22,90		



ΡΑΚΟΡ ΓΩΝΙΑ 90° ΠΡΕΣΣΑΡΙΣΤΟ ΑΥΤΟΜΑΤΟ QO

ΚΩΔΙΚΟΣ	ΣΠΕΙΡΩΜΑ	ΔΙΑΜΕΤΡΟΣ	€	+ ΦΠΑ
MK-000506	1\4	9,70		
MK-000510	3\8	12,10		
MK-000513	1\2	16,00		
MK-000519	3\4	22,90		



ΡΑΚΟΡ ΑΜΒΛΕΙΑ 45° ΠΡΕΣΣΑΡΙΣΤΟ ΑΥΤΟΜΑΤΟ QO

ΚΩΔΙΚΟΣ	ΣΠΕΙΡΩΜΑ	ΔΙΑΜΕΤΡΟΣ	€	+ ΦΠΑ
MK-000406	1\4	9,7		
MK-000410	3\8	12,1		
MK-000413	1\2	16		
MK-000419	3\4	22,9		

Νέα σειρά ρακόρ κατασκευασμένη ειδικά για περιορισμένους χώρους ώστε να προσαρμόζεται εύκολα χωρίς την χρήση κλειδιών και να παρέχει περιστροφή στον σωλήνα.
Κατάλληλη για γερανούς ανυψωτικά, γεωργικά μηχανήματα

ΡΑΚΟΡ Οικονομικής σειράς 60



ΘΗΛΥΚΑ B.S.P.

ΓΩΝΙΕΣ 90° B.S.P

ΑΜΒΛΙΕΣ 45° B.S.P

ΚΩΔΙΚΟΣ	ΣΠΕΙΡΩΜΑ	ΟΥΡΑ	ΣΚΕΤΑ	ΚΩΔΙΚΟΣ	ΣΠΕΙΡΩΜΑ	ΟΥΡΑ	ΣΚΕΤΑ	ΚΩΔΙΚΟΣ	ΣΠΕΙΡΩΜΑ	ΟΥΡΑ	ΣΚΕΤΑ
60-100605	1/4	3/16		60-110605	1/4	3/16		60-140605	1/4	3/16	
60-100306	1/8			60-110606	1/4			60-140606	1/4		
60-100606	1/4	1/4		60-111006	3/8	1/4		60-141006	3/8	1/4	
60-101006	3/8			60-111306	1/2			60-141306	1/2		
60-101306	1/2			60-110608	1/4			60-141008	3/8		
60-100608	1/4	5/16		60-111008	3/8	5/16		60-141308	1/2	5/16	
60-101008	3/8			60-111308	1/2			60-140610	1/4		
60-101308	1/2			60-110610	1/4			60-141010	3/8	3/8	
60-100610	1/4	3/8		60-111010	3/8	3/8		60-141310	1/2		
60-101010	3/8			60-111310	1/2			60-141313	1/2	1/2	
60-101310	1/2			60-111013	3/8			60-141616	5/8		
60-101013	3/8	1/2		60-111313	1/2	1/2		60-141916	3/4	5/8	
60-101313	1/2			60-111613	5/8			60-141919	3/4	3/4	
60-101613	5/8			60-111913	3/4			60-142519	1"		
60-101912	3/4			60-111316	1/2			60-142525	1"	1"	
60-101316	1/2	5/8		60-111616	5/8	5/8		60-143232	1"1/4	1"1/4	
60-101616	5/8			60-111916	3/4			60-143838	1"1/2	1"1/2	
60-101916	3/4			60-111919	3/4	3/4		60-145050	2"	2"	
60-101919	3/4	3/4		60-112519	1"						
60-102519	1"			60-112525	1"	1"					
60-102525	1"	1"		60-113225	1"1/4						
60-103225	1"1/4			60-113232	1"1/4	1"1/4					
60-103232	1"1/4	1"1/4		60-113832	1"1/2	1"1/4					
60-103832	1"1/2			60-113838	1"1/2	1"1/2					
60-103838	1"1/2	1"1/2		60-115050	2"	2"					
60-105050	2"	2"									



ΜΙΚΡΟ ΕΞΑΓΩΝΟ

ΑΡΣΕΝΙΚΑ B.S.P



ΚΥΑΘΙΑ R1T ΑΚΑΘΑΡΙΣΤΑ				ΚΥΑΘΙΑ R2T ΑΚΑΘΑΡΙΣΤΑ							
60-318006	1/4			60-319006	1/4			60-130306	1/8		
60-318008	5/16			60-319008	5/16			60-130606	1/4	1/4	
60-318010	3/8			60-319010	3/8			60-131006	3/8		
60-318013	1/2			60-319013	1/2			60-131306	1/2		
60-318016	5/8			60-319016	5/8			60-130608	1/4	5/16	
60-318019	3/4			60-319019	3/4			60-131008	3/8		
60-318025	1"			60-319025	1"			60-131308	1/2		
								60-130610	1/4		
								60-131010	3/8	3/8	
								60-131310	1/2		
								60-131013	3/8		
								60-131313	1/2	1/2	
								60-131613	5/8		
								60-131913	3/4		
								60-131316	1/2		
								60-131616	5/8	5/8	
								60-131916	3/4		
								60-131919	3/4	3/4	
								60-132519	1"		
								60-132525	1"	1"	
								60-133225	1"1/4		
								60-133232	1"1/4	1"1/4	
								60-133832	1"1/2	1"1/4	
								60-133838	1"1/2	1"1/2	
								60-135050	2"	2"	



ΑΡΣΕΝΙΚΑ ΣΕΙΡΑ L

ΚΩΔΙΚΟΣ	ΣΠΕΙΡΩΜΑ	ΣΩΛΗΝΑ	ΕΔΡΑ	ΣΚΕΤΑ
60-150505	10X1	3\16	6LL	
60-151205	12X1,5		6L	
60-150506	10X1	1\4	6LL	
60-151206	12X1,5		6L	
60-151406	14X1,5		8L	
60-151606	16X1,5		10L	
60-151806	18X1,5	5\16	12L	
60-151408	14X1,5		8L	
60-151608	16X1,5		10L	
60-151808	18X1,5	3\8	12L	
60-151610	16X1,5		10L	
60-151810	18X1,5	1\2	12L	
60-152210	22X1,5		15L	
60-151813	18X1,5	5\8	12L	
60-152213	22X1,5		15L	
60-152613	26X1,5	3\4	18L	
60-152216	22X1,5		15L	
60-152616	26X1,5	1"	18L	
60-152716	27X1,5		18L	
60-152717	27X2	1"1\4	22L	
60-153017	30X2		28L	
60-152619	26X1,5	1"1\2	22L	
60-152719	27X2		18L	
60-153019	30X2		28L	
60-153625	36X2		35L	
60-154525	45X2		35L	
60-154532	45X2		42L	
60-155238	52X2		42L	

ΑΡΣΕΝΙΚΑ ΣΕΙΡΑ S

60-150605	14X1,5	3\16	6S	
60-150606	14X1,5	1\4	6S	
60-150806	16X1,5		8S	
60-151006	18X1,5	5\16	10S	
60-152006	20X1,5		12S	
60-151008	18X1,5	3\8	10S	
60-152008	20X1,5		12S	
60-151010	18X1,5	1\2	10S	
60-152010	20X1,5		12S	
60-152211	22X1,5	5\8	14S	
60-152013	20X1,5		12S	
60-152214	22X1,5	3\4	14S	
60-152413	24X1,5		16S	
60-152416	24X1,5	1"	16S	
60-153016	30X2		20S	
60-153022	30X2	1"1\4	20S	
60-153619	36X2		25S	
60-153626	36X2		25S	
60-154225	42X2		30S	
60-154232	42X2		30S	
60-155232	52X2		38S	



ΘΗΛΥΚΑ ΣΕΙΡΑ L240 ΕΔΡΑ

ΚΩΔΙΚΟΣ	ΣΠΕΙΡΩΜΑ	ΣΩΛΗΝΑ	ΕΔΡΑ	ΣΚΕΤΑ
60-161205	12X1,5	3\16	6L	
60-161206	12X1,5	1\4	6L	
60-161406	14X1,5		8L	
60-161606	16X1,5		10L	
60-161806	18X1,5		12L	
60-161408	14X1,5	5\16	8L	
60-161608	16X1,5		10L	
60-161808	18X1,5		12L	
60-162208	22X1,5		15L	
60-161610	16X1,5	3\8	10L	
60-161810	18X1,5		12L	
60-162210	22X1,5		15L	
60-161813	18X1,5	1\2	12L	
60-162213	22X1,5		15L	
60-162613	26X1,5		18L	
60-162713	27X1,5		18L	
60-162216	22X1,5	5\8	15L	
60-162616	26X1,5		18L	
60-162716	27X1,5		18L	
60-163017	30X2	3\4	22L	
60-162619	26X1,5		18L	
60-162719	27X2			
60-163019	30X2		22L	
60-163620	36X2	1"	28L	
60-163625	36X2		28L	
60-164525	45X2	1"1\4	35L	
60-164532	45X2		35L	
60-165233	52X2	1"1\2	42L	
60-165238	52X2		42L	

ΘΗΛΥΚΑ ΣΕΙΡΑ S

60-160605	14X1,5	3\16	6S	
60-160606	14X1,5	1\4	6S	
60-160806	16X1,5		8S	
60-161006	18X1,5	5\16	10S	
60-162006	20X1,5		12S	
60-161008	18X1,5	3\8	10S	
60-162008	20X1,5		12S	
60-161010	18X1,5	1\2	10S	
60-162010	20X1,5		12S	
60-162211	22X1,5	5\8	14S	
60-162013	20X1,5		12S	
60-162214	22X1,5	3\4	14S	
60-162413	24X1,5		16S	
60-163013	30X2	1"	20S	
60-162416	24X1,5		16S	
60-163016	30X2	1"1\4	20S	
60-163022	30X2		20S	
60-163619	36X2	1"1\2	25S	
60-163626	36X2		25S	
60-164225	42X2		30S	
60-165225	52X2		38S	
60-164232	42X2		30S	
60-165232	52X2		38S	
60-163838	52X2		38S	

ΡΑΚΟΡ Οικονομικής σειράς 60



24ο ΕΔΡΑ

ΓΩΝΙΕΣ 90° ΣΕΙΡΑ L

ΚΩΔΙΚΟΣ	ΣΠΕΙΡΩΜΑ	ΣΩΛΗΝΑ	ΕΔΡΑ	ΣΚΕΤΑ
60-171205	12X1,5	3\16	6L	
60-171206	12X1,5	1\4	6L	
60-171406	14X1,5		8L	
60-171606	16X1,5		10L	
60-171806	18X1,5		12L	
60-171408	14X1,5		8L	
60-171608	16X1,5	5\16	10L	
60-171808	18X1,5		12L	
60-171610	16X1,5		10L	
60-171810	18X1,5	3\8	12L	
60-172210	22X1,5		15L	
60-171813	18X1,5	1\2	12L	
60-172213	22X1,5		15L	
60-172613	26X1,5		18L	
60-172216	22X1,5	5\8	15L	
60-172616	26X1,5		18L	
60-172716	27X1,5		18L	
60-173017	30X2		22L	
60-172619	26X1,5		18L	
60-173019	30X2	3\4	22L	
60-173620	36X2		28L	
60-173625	36X2	1"4SH	28L	
60-174525	45X2		35L	
60-174532	45X2		1"1\4	35L
60-175238	52X2	1"1\2	42L	

ΓΩΝΙΕΣ 90° ΣΕΙΡΑ S

60-170605	14X1,5	3\16	6S	
60-170606	14X1,5	1\4	6S	
60-170806	16X1,5		8S	
60-171006	18X1,5		10S	
60-172006	20X1,5		12S	
60-171008	18X1,5		10S	
60-172008	20X1,5	5\16	12S	
60-171010	18X1,5		10S	
60-172010	20X1,5		12S	
60-172211	22X1,5	3\8	14S	
60-172013	20X1,5		12S	
60-172214	22X1,5	1\2	14S	
60-172413	24X1,5		16S	
60-172413	24X1,5		16S	
60-173016	30X2	5\8	20S	
60-173022	30X2		20S	
60-173619	36X2	3\4	25S	
60-173626	36X2		25S	
60-174225	42X2		30S	
60-173825	52X2	1"4SH	38S	
60-174232	42X2		30S	
60-175232	52X2	1"1\4	38S	



24ο ΕΔΡΑ

ΑΜΒΛΙΕΣ 45° ΣΕΙΡΑ L

ΚΩΔΙΚΟΣ	ΣΠΕΙΡΩΜΑ	ΣΩΛΗΝΑ	ΕΔΡΑ	ΣΚΕΤΑ
60-381205	12X1,5	3\16	6L	
60-381206	12X1,5	1\4	6L	
60-381406	14X1,5		8L	
60-381606	16X1,5		10L	
60-381806	18X1,5		12L	
60-381408	14X1,5		8L	
60-381608	16X1,5	5\16	10L	
60-381808	18X1,5		12L	
60-381610	16X1,5		10L	
60-381810	18X1,5	3\8	12L	
60-382210	22X1,5		15L	
60-381813	18X1,5	1\2	12L	
60-382213	22X1,5		15L	
60-382613	26X1,5		18L	
60-382616	26X1,5	5\8	18L	
60-382716	27X1,5		18L	
60-383017	30X2		22L	
60-382619	26X1,5		18L	
60-383019	30X2		22L	
60-383625	36X2	1"4SH	28L	
60-384525	45X2		35L	
60-384532	45X2	1"1\4	35L	
60-385238	52X2	1"1\2	42L	

ΑΜΒΛΙΕΣ 45° ΣΕΙΡΑ S

60-380605	14X1,5	3\16	6S	
60-380606	14X1,5	1\4	6S	
60-380806	16X1,5		8S	
60-381006	18X1,5		10S	
60-382006	20X1,5		12S	
60-381008	18X1,5		10S	
60-382008	20X1,5	5\16	12S	
60-381010	18X1,5		10S	
60-382010	20X1,5		12S	
60-382211	22X1,5	3\8	14S	
60-382013	20X1,5		12S	
60-382214	22X1,5	1\2	14S	
60-382413	24X1,5		16S	
60-383016	30X2		5\8	20S
60-383022	30X2	3\4	20S	
60-383619	36X2		25S	
60-383626	36X2	1"4SH	25S	
60-384225	42X2		30S	
60-383825	52X2		38S	
60-384232	42X2	1"1\4	30S	
60-385232	52X2		38S	

ΦΛΑΝΤΖΩΤΑ 3000 p.s.i



ΙΣΙΑ 3000psi				ΑΜΒΛΕΙΕΣ 45° 3000psi				ΓΩΝΙΕΣ 90° 3000psi			
ΚΩΔΙΚΟΣ	ΦΛΑΝΤΖΑ	ΣΩΛ	ΣΚΕΤΑ	ΚΩΔΙΚΟΣ	ΦΛΑΝΤΖΑ	ΣΩΛ	ΣΚΕΤΑ	ΚΩΔΙΚΟΣ	ΦΛΑΝΤΖΑ	ΣΩΛ	ΣΚΕΤΑ
60-203013	30,2	1½		60-213013	30,2	1½		60-223013	30,2	1½	
60-203813	38,1			60-213813	38,1			60-223813	38,1		
60-203016	30,2	5/8		60-213016	30,2	5/8		60-223016	30,2	5/8	
60-203816	38,1			60-213816	38,1			60-223816	38,1		
60-203019	30,2	3/4		60-213019	30,2	3/4		60-223019	30,2	3/4	
60-203819	38,1			60-213819	38,1			60-223819	38,1		
60-204419	44,5			60-214419	44,5			60-224419	44,5		
60-205019	50,8			60-215019	50,8			60-225019	50,8		
60-204425	44,5	1"		60-214425	44,5	1"		60-224425	44,5	1"	
60-205025	50,8			60-215025	50,8			60-225025	50,8		
60-206025	60,3	1¼		60-216025	60,3	1¼		60-226025	60,3	1¼	
60-204432	44,5			60-214432	44,5			60-224432	44,5		
60-205032	50,8			60-215032	50,8			60-225032	50,8		
60-206032	60,3			60-216032	60,3			60-226032	60,3		
60-205038	50,8	1½		60-215038	50,8	1½		60-225038	50,8	1½	
60-206038	60,3			60-216038	60,3			60-226038	60,3		
60-207138	71,4	2"		60-217138	71,4	2"		60-227138	71,4	2"	
60-207150	71,4			60-217150	71,4			60-227150	71,4		

ΦΛΑΝΤΖΩΤΑ 6000 p.s.i

ΙΣΙΑ 6000psi				ΑΜΒΛΕΙΕΣ 45° 6000psi				ΓΩΝΙΕΣ 90° 6000psi			
ΚΩΔΙΚΟΣ	ΦΛΑΝΤΖΑ	ΣΩΛ	ΣΚΕΤΑ	ΚΩΔΙΚΟΣ	ΦΛΑΝΤΖΑ	ΣΩΛ	ΣΚΕΤΑ	ΚΩΔΙΚΟΣ	ΦΛΑΝΤΖΑ	ΣΩΛ	ΣΚΕΤΑ
60-203113	31,7	1½		60-213113	31,7	1½		60-223113	31,7	1½	
60-204113	41,3			60-214113	41,3			60-224113	41,3		
60-203116	31,7	5/8		60-213116	31,7	5/8		60-223116	31,7	5/8	
60-204116	41,3			60-214116	41,3			60-224116	41,3		
60-204816	47,6	3/4		60-214816	47,6	3/4		60-224816	47,6	3/4	
60-203119	31,7			60-213119	31,7			60-223119	31,7		
60-204119	41,3			60-214118	41,3			60-224118	41,3		
60-204819	47,6			60-214819	47,6			60-224819	47,6		
60-204125	41,3	1"		60-214125	41,3	1"		60-224125	41,3	1"	
60-204825	47,6			60-214825	47,6			60-224825	47,6		
60-205425	54	1¼		60-215425	54	1¼		60-225425	54	1¼	
60-204832	47,6			60-214832	47,6			60-224832	47,6		
60-205432	54			60-215432	54			60-225432	54		
60-206332	63,5			60-216332	63,5			60-226332	63,5		
60-206338	63,5	1½		60-216338	63,5	1½		60-226338	63,5	1½	
60-207938	79,4			60-217938	79,4			60-227938	79,4		
60-207950	79,4	2"		60-217950	79,4	2"		60-227950	79,4	2"	

ΦΛΑΝΤΖΩΤΑ 6000 p.s.i SUPERCAT 14mm

ΙΣΙΑ 6000psi 14mm supercat				45° 6000psi 14mm supercat				90° 6000psi 14mm supercat			
ΚΩΔΙΚΟΣ	ΦΛΑΝΤΖΑ	ΣΩΛ	ΣΚΕΤΑ	ΚΩΔΙΚΟΣ	ΦΛΑΝΤΖΑ	ΣΩΛ	ΣΚΕΤΑ	ΚΩΔΙΚΟΣ	ΦΛΑΝΤΖΑ	ΣΩΛ	ΣΚΕΤΑ
60-604119	41,3	3/4		60-614119	41,3	3/4		60-624119	41,3	3/4	
60-604819	47,6			60-614819	47,6			60-624819	47,6		
60-604825	47,6	1"		60-614825	47,6	1"		60-624825	47,6	1"	
60-605425	54			60-615425	54			60-625425	54		
60-605432	54	1" 1/4		60-615432	54	1" 1/4		60-625432	54	1" 1/4	
60-606332	63,5			60-616332	63,5			60-626332	63,5		
60-606338	63,5	1½		60-616338	63,5	1½		60-626338	63,5	1½	



ΑΡΣΕΝΙΚΑ U.N.F

ΚΩΔΙΚΟΣ	ΣΠΕΙΡΩΜΑ	ΣΩΛΗΝ	ΣΚΕΤΑ
60-231106	7\16	1\4	
60-231306	1\2X20		
60-231406	9\16		
60-231308	1\2X20	5\16	
60-231408	9\16		
60-231608	5\8X18		
60-231410	9\16	3\8	
60-231610	5\8X18		
60-231910	3\4X16		
60-232210	7\8		
60-231913	3\4X16	1\2	
60-232213	7\8		
60-232713	1"1\16		
60-232216	7\8	5\8	
60-232716	1"1\16		
60-232719	1"1\16	3\4	
60-233019	1"3\16		
60-233319	1"5\16		
60-233325	1"5\16	1"	
60-234125	1"5\8		
60-234132	1"5\8	1" 1\4	
60-234732	1"7\8		
60-234738	1"7\8	1\2	
60-236350	2"1\2	2"	

ΘΗΛΥΚΑ U.N.F

ΚΩΔΙΚΟΣ	ΣΠΕΙΡΩΜΑ	ΣΩΛΗΝ	ΣΚΕΤΑ
60-241106	7\16	1\4	
60-241306	1\2X20		
60-241406	9\16		
60-241108	7\16	5\16	
60-241308	1\2X20		
60-241408	9\16		
60-241608	5\8X18		
60-241908	3\4X16	3\8	
60-241410	9\16		
60-241610	5\8X18		
60-241910	3\4X16	1\2	
60-242210	7\8		
60-241913	3\4X16	5\8	
60-242213	7\8		
60-242713	1"1\16	3\4	
60-242216	7\8		
60-242716	1"1\16		
60-242719	1"1\16	1"	
60-243019	1"3\16		
60-243319	1"5\16	1" 1\4	
60-242725	1"1\16		
60-243325	1"5\16	1\2	
60-244125	1"5\8		
60-244132	1"5\8	1" 1\4	
60-244738	1"7\8	1\2	



ΓΩΝΙΕΣ U.N.F 90°

ΚΩΔΙΚΟΣ	ΣΠΕΙΡΩΜΑ	ΣΩΛΗΝ	ΣΚΕΤΑ
60-251106	7\16	1\4	
60-251306	1\2X20		
60-251406	9\16		
60-251308	1\2X20	5\16	
60-251408	9\16		
60-251608	5\8X18		
60-251410	9\16	3\8	
60-251610	5\8X18		
60-251910	3\4X16		
60-252210	7\8		
60-251913	3\4X16	1\2	
60-252213	7\8		
60-252713	1"1\16		
60-252216	7\8	5\8	
60-252716	1"1\16		
60-252719	1"1\16	3\4	
60-253019	1"3\16		
60-253319	1"5\16		
60-253325	1"5\16	1"	
60-254125	1" 5\8		
60-254132	1" 5\8	1" 1\4	
60-254738	1"7\8	1\2	



ΑΜΒΛΙΕΣ U.N.F 45°

ΚΩΔΙΚΟΣ	ΣΠΕΙΡΩΜΑ	ΣΩΛΗΝ	ΣΚΕΤΑ
60-261106	7\16	1\4	
60-261306	1\2X20		
60-261406	9\16		
60-261308	1\2X20	5\16	
60-261408	9\16		
60-261608	5\8X18		
60-261410	9\16		
60-261910	3\4X16	3\8	
60-261913	3\4X16		
60-262213	7\8		
60-262713	1"1\16	1\2	
60-262216	7\8		
60-262716	1" 1\16	5\8	
60-262719	1"1\16		
60-263019	1"3\16		
60-263319	1"5\16	3\4	
60-263325	1" 5\16		
60-264132	1" 5\8	1" 1\4	
60-264738	1"7\8	1\2	



ΑΡΣΕΝΙΚΑ Ο.Ρ.Φ.Σ.

ΚΩΔΙΚΟΣ	ΣΠΕΙΡΩΜΑ	ΣΩΛΗΝ	ΣΚΕΤΑ
60-421406	9\16	1\4	
60-421706	11\16		
60-421408	9\16	5\16	
60-421708	11\16		
60-421710	11\16	3\8	
60-422010	13\16		
60-422013	13\16	1\2	
60-422513	1" X 14		
60-423013	1" 3\16	5\8	
60-422516	1" X 14		
60-423016	1" 3\16	3\4	
60-422519	1" X 14		
60-423019	1" 3\16	1"	
60-423719	1"7\16		
60-423725	1"7\16	1"1\4	
60-424225	1"11\16		
60-424232	1"11\16	1"1\2	
60-425038	2"X12		

ΘΗΛΥΚΑ Ο.Ρ.Φ.Σ.

ΚΩΔΙΚΟΣ	ΣΠΕΙΡΩΜΑ	ΣΩΛΗΝ	ΣΚΕΤΑ
60-391406	9\16	1\4	
60-391706	11\16		
60-391408	9\16	5\16	
60-391708	11\16		
60-391710	11\16	3\8	
60-392010	13\16		
60-391713	11\16	1\2	
60-392013	13\16		
60-392513	1" X 14	5\8	
60-393013	1" 3\16		
60-392516	1" X 14	3\4	
60-393016	1" 3\16		
60-393019	1" 3\16	1"	
60-393719	1"7\16		
60-393725	1"7\16	1"1\4	
60-394225	1"11\16		
60-394232	1"11\16	1"1\2	
60-395038	2"X12		



ΓΩΝΙΕΣ Ο.Ρ.Φ.Σ.

ΚΩΔΙΚΟΣ	ΣΠΕΙΡΩΜΑ	ΣΩΛΗΝ	ΣΚΕΤΑ
60-411406	9\16	1\4	
60-411706	11\16		
60-411408	9\16	5\16	
60-411708	11\16		
60-411710	11\16	3\8	
60-412010	13\16		
60-412013	13\16	1\2	
60-412513	1" X 14		
60-413013	1" 3\16	5\8	
60-412516	1" X 14		
60-413016	1" 3\16	3\4	
60-413019	1" 3\16		
60-413719	1"7\16	1"	
60-413725	1"7\16		
60-414225	1"11\16	1"1\4	
60-414232	1"11\16		

ΑΜΒΛΕΙΕΣ Ο.Ρ.Φ.Σ.

ΚΩΔΙΚΟΣ	ΣΠΕΙΡΩΜΑ	ΣΩΛΗΝ	ΣΚΕΤΑ
60-401406	9\16	1\4	
60-401706	11\16		
60-401408	9\16	5\16	
60-401708	11\16		
60-401710	11\16	3\8	
60-402010	13\16		
60-402013	13\16	1\2	
60-402513	1" X 14		
60-403013	1" 3\16	5\8	
60-402516	1" X 14		
60-403016	1" 3\16	3\4	
60-403019	1" 3\16		
60-403719	1"7\16	1"	
60-403725	1"7\16		
60-404225	1"11\16	1"1\4	
60-404232	1"11\16		

ΔΙΑΜΕΤΡΟΙ ΣΤΕΙΡΟΜΑΤΩΝ

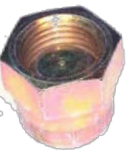

ΑΡΣΕΝΙΚΟ	ΔΙΑΜΕΤΡΟΣ	ΘΥΛΑΥΚΟ
5/16X24 UNF	7,15	5/16X24 UNF
	7,94	
	8,6	3/8X24 UNF
	8,7	1/8X28 B.S.P
1/8X27 N.P.T	9,5	
3/8X24 UNF	9,52	
1/8X28 B.S.P	9,6	
10X1	9,8	
	9,9	7/16X20 U.N.F
	10,5	12X1,5
7/16X20 U.N.F	11	
	11,4	1/2X20 U.N.F
	11,6	1/4X19 B.S.P
12X1,5	11,9	
1/4X18 N.P.T	12,5	
	12,5	14X1,5
1/2X20 U.N.F	12,6	
	12,9	9/16X18 U.N.F
1/4X19 B.S.P	13	
14X1,5	13,9	
9/16X18 U.N.F	14,2	
	14,5	5/8X18 U.N.F
	14,5	16X1,5
	15,1	3/8X19 B.S.P
	15,4	11/16X16 ORFS
5/8X18 U.N.F	15,7	
16X1,5	15,8	
3/8X19 N.P.T	15,9	
	16,5	18X1,5
3/8X19 B.S.P	16,6	
11/16X16 ORFS	17,4	
	17,5	3/4X16 UNF
18X1,5	17,9	
	18,5	20X1,5
3/4X16 UNF	18,8	
	19	1/2X14 B.S.P
	19	13/16X16 ORFS

ΑΡΣΕΝΙΚΟ	ΔΙΑΜΕΤΡΟΣ	ΘΥΛΑΥΚΟ
1/2X14 NPT	19,8	
20X1,5	19,9	
	20,4	7/8X14 UNF
13/16X16 ORFS	20,5	
	20,5	22X1,5
1/2X14 B.S.P	20,8	
	20,9	5/8X14 BSP
22X1,5	21,9	
7/8X14 UNF	22,1	
	22,5	24X1,5
5/8X14 BSP	22,8	
	23,1	1" X14 ORFS
24X1,5	23,9	
	24,4	26X1,5
	24,5	3/4X14 BSP
	24,8	1" 1/16X12 UNF
3/4X14 NPT	25,1	
1" X14 ORFS	25,3	
26X1,5	25,9	
3/4X14 BSP	26,3	
1" 1/16X12 UNF	26,8	
	27,9	1" 3/16X12 UNF
	28	30X2
	28,5	30X1,5
30X2	29,8	
30X1,5	29,9	
1" 3/16X12 UNF	30,1	
	30,7	1" X11 BSP
	31,2	1" 5/16X12 UNF
1" X11,5 NPT	31,4	
	31,5	33X1,5
1" X11 BSP	33,1	
1" 5/16X12 UNF	33,2	
	34	36X2
	34,5	36X1,5
	34,5	1" 7/16X12ORFS
36X2	35,8	

ΑΡΣΕΝΙΚΟ	ΔΙΑΜΕΤΡΟΣ	ΘΥΛΑΥΚΟ
36X1,5	35,9	
	36,5	38X1,5
1" 7/16X12ORFS	36,5	
38X1,5	37,9	
	38,8	1" 5/8X12 UNF
	39,4	1" 1/4X11 BSP
	39,8	42X2
1" 1/4X11,5 NPT	40,2	
	40,2	1" 1/16X12ORFS
	40,5	42X1,5
1" 5/8X12 UNF	41,1	
1" 1/4X11 BSP	41,7	
42X2	41,8	
	42,4	45X2
1" 1/16X12ORFS	42,8	
	43,3	45X1,5
45X2	44,8	
45X1,5	44,9	
	45,1	1" 7/8X12 UNF
	45,2	1" 1/2X11 BSP
1" 1/2X11,5 NPT	46,3	
1" 7/8X12 UNF	47,5	
1" 1/2 X11 BSP	47,7	
	48,5	2" X12ORFS
	49,6	52X2
2" X12ORFS	50	
52X2	51,8	
	57,4	2" X11 BSP
2" X11,5 NPT	58,3	
2" X11 BSP	59,4	
	61,5	2" 1/2X12 UNF
2" 1/2X12 UNF	63,3	
	73,0	2" 1/2 X11 BSP
2" 1/2 X11 BSP	75,1	
	85,5	3" X11 BSP
3" X11 BSP	87,8	

BSP
NPT
UNF
METRIC
ORFS

PM18 1"R2
80 tones

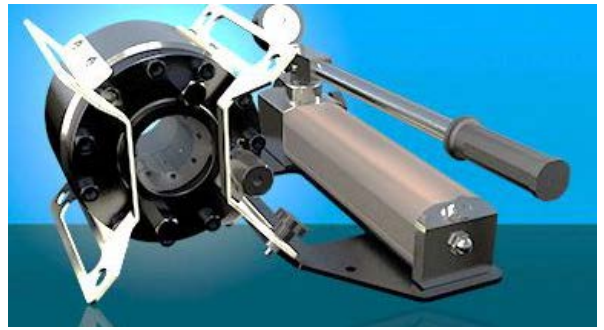

H 110 1"4sp
110 tones

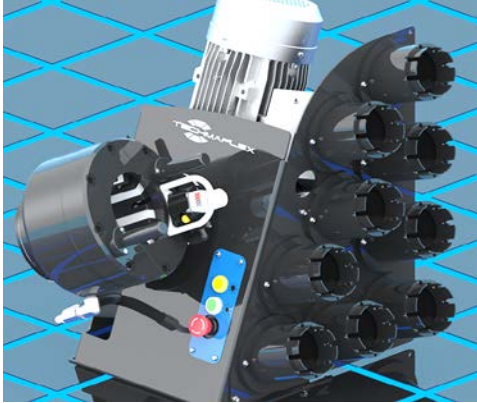

S 137 1" 1/4 4SP
137 ton.πρεσ/σμα 4-70mm



S CRIMP 240 EVO
2" 4SH 240 ton.

2" 6SP -4" IND. 350 ton.

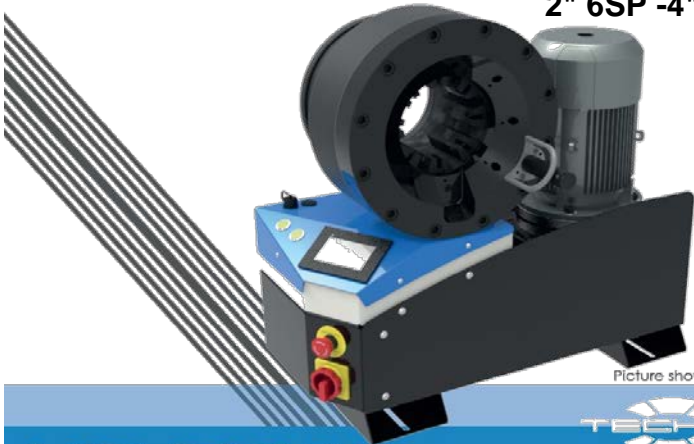

Picture showing S CRIMP 350 EVO SCS

S CRIMP 350 EVO



ΚΟΠΤΙΚΟ S CUT 32L

ΣΩΛΗΝΩΝ ΠΙΕΣΕΩΣ
ΚΟΠΗ ΑΠΟ 1/8-2"



ΚΟΥΡΜΠΑΔΩΡΟΣ 6-18MM



ΠΡΕΣΣΑ ΣΩΛΗΝΩΝ FLEX
SCMITTER GERMANY



ΡΑΚΟΡ ΑΝΟΞΕΙΔΩΤΑ (INOX) AISI 316L

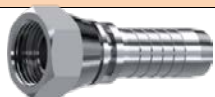

ΘΗΛΥΚΑ B.S.P. INOX

ΚΩΔΙΚΟΣ	ΣΠΕΙΡΩΜΑ	ΟΥΡΑ	ΣΚΕΤΑ	ΚΟΜΠΛΕ	+ΦΠΑ
PI-100605	1\4	3\16			
PI-100306	1\8				
PI-100606	1\4	1\4			
PI-101006	3\8				
PI-101008	3\8	5\16			
PI-101010	3\8				
PI-101310	1\2	3\8			
PI-101013	3\8				
PI-101313	1\2	1\2			
PI-101919	3\4	3\4			
PI-102525	1"	1"			
PI-103232	1"1\4	1"1\4			
PI-103838	1"1\2	1"1\2			



ΓΩΝΙΕΣ B.S.P. INOX

ΚΩΔΙΚΟΣ	ΣΠΕΙΡΩΜΑ	ΟΥΡΑ	ΣΚΕΤΑ	ΚΟΜΠΛΕ	+ΦΠΑ
PI-110605	1\4	3\16			
PI-110606	1\4				
PI-111006	3\8	1\4			
PI-111010	3\8	3\8			
PI-111313	1\2	1\2			
PI-111919	3\4	3\4			
PI-112525	1"	1"			
PI-113232	1"1\4	1"1\4			
PI-113838	1"1\2	1"1\2			



ΑΡΣΕΝΙΚΑ N.P.T. INOX

ΚΩΔΙΚΟΣ	ΣΠΕΙΡΩΜΑ	ΟΥΡΑ	ΣΚΕΤΑ	ΚΟΜΠΛΕ	+ΦΠΑ
PI-120606	1\4				
PI-121006	3\8	1\4			
PI-121010	3\8				
PI-121310	1\2	3\8			
PI-121013	3\8				
PI-121313	1\2	1\2			
PI-121919	3\4	3\4			
PI-122525	1"	1"			



ΑΡΣΕΝΙΚΑ B.S.P. INOX

ΚΩΔΙΚΟΣ	ΣΠΕΙΡΩΜΑ	ΟΥΡΑ	ΣΚΕΤΑ	ΚΟΜΠΛΕ	+ΦΠΑ
PI-130606	1\4	1\4			
PI-131006	3\8				
PI-131010	3\8	3\8			
PI-131310	1\2				
PI-131313	1\2	1\2			
PI-131919	3\4	3\4			
PI-132525	1"	1"			



ΘΗΛΥΚΑ ΜΕΤΡΙΚΑ 24° INOX

ΚΩΔΙΚΟΣ	ΣΠΕΙΡΩΜΑ	ΟΥΡΑ	ΣΚΕΤΑ	ΚΟΜΠΛΕ	+ΦΠΑ
PI-151206	6L				
PI-151406	8L	1\4			
PI-151606	10L				
PI-151608	10L	5\16			
PI-151810	12L	3\8			
PI-152213	15L	1\2			
PI-161205	6L	3\16			
PI-161405	8L				
PI-161206	6L				
PI-161406	8L	1\4			
PI-161606	10L				
PI-161608	10L	5\16			
PI-161808	12L				
PI-161810	12L	3\8			
PI-162010	12S				
PI-162213	15L	1\2			
PI-162413	16S				
PI-162616	18L	5\8			
PI-163016	20S				



ΑΡΣΕΝΙΚΑ ΜΕΤΡΙΚΑ 24° INOX

ΚΩΔΙΚΟΣ	ΣΠΕΙΡΩΜΑ	ΟΥΡΑ	ΣΚΕΤΑ	ΚΟΜΠΛΕ	+ΦΠΑ
PI-171205	6L	3\16			
PI-171206	6L				
PI-171406	8L	1\4			
PI-171606	10L				
PI-171608	10L	5\16			
PI-171810	12L	3\8			
PI-172010	12S				
PI-172213	15L	1\2			
PI-172413	16S				
PI-172616	18L	5\8			
PI-173016	20S				



ΓΩΝΙΕΣ ΜΕΤΡΙΚΕΣ 24° INOX

ΚΩΔΙΚΟΣ	ΣΠΕΙΡΩΜΑ	ΟΥΡΑ	ΣΚΕΤΑ	ΚΟΜΠΛΕ	+ΦΠΑ
PI-171205	6L	3\16			
PI-171206	6L				
PI-171406	8L	1\4			
PI-171606	10L				
PI-171608	10L	5\16			
PI-171810	12L	3\8			
PI-172010	12S				
PI-172213	15L	1\2			
PI-172413	16S				
PI-172616	18L	5\8			
PI-173016	20S				



ΘΗΛΥΚΑ U.N.F. INOX

ΚΩΔΙΚΟΣ	ΣΠΕΙΡΩΜΑ	ΟΥΡΑ	ΣΚΕΤΑ	ΚΟΜΠΛΕ	+ΦΠΑ
PI-241105	7\16	3\16			
PI-241106	7\16				
PI-241306	1\2X20	1\4			
PI-241406	9\16				
PI-241408	9\16	5\16			
PI-241410	9\16	3\8			
PI-241910	3\4X16				
PI-241913	3\4X16	1\2			
PI-242213	7\8				



RZ ΙΣΙΑ

ΚΩΔΙΚΟΣ	ΣΠΕΙΡΩΜΑ	ΟΥΡΑ	ΣΚΕΤΑ	ΚΟΜΠΛΕ	+ΦΠΑ
PI-180605	6L-S	3\16			
PI-180606	6L-S	1\4			



RZ 90ο

ΚΩΔΙΚΟΣ	ΣΠΕΙΡΩΜΑ	ΟΥΡΑ	ΣΚΕΤΑ	ΚΟΜΠΛΕ	+ΦΠΑ
PI-190605	6L-S	3\16			
PI-190606	6L-S	1\4			

ΡΑΚΟΡ ΑΝΟΞΕΙΔΩΤΑ INOX AISI 316



ΓΩΝΙΕΣ U.N.F. INOX

ΚΩΔΙΚΟΣ	ΣΠΕΙΡΩΜΑ	ΟΥΡΑ	ΣΚΕΤΑ	ΚΟΜΠΛΕ	+ΦΠΑ
PI-251106	7\16	1\4			
PI-251306	1\2X20				
PI-251406	9\16	5\16			
PI-251408	9\16				
PI-251410	9\16	3\8			
PI-251910	3\4X16				
PI-251913	3\4X16	1\2			
PI-252213	7\8				



ΘΗΛΥΚΑ ORFS INOX

ΚΩΔΙΚΟΣ	ΣΠΕΙΡΩΜΑ	ΟΥΡΑ	ΣΚΕΤΑ	ΚΟΜΠΛΕ	+ΦΠΑ
PI-391406	9\16	1\4			



ΚΑΘΑΡΙΣΜΕΝΑ



ΚΥΑΘΙΑ INOX R7-MTH1

ΚΥΑΘΙΑ INOX R2-4SP				ΚΩΔΙΚΟΣ	ΠΕΡΙΓΡΑΦΗ	€	+ΦΠΑ
ΚΩΔΙΚΟΣ	ΠΕΡΙΓΡΑΦΗ	€	+ΦΠΑ				
PI-310602	1\4			PI-317005	3\16		
PI-310802	5\16			PI-317006	1\4		
PI-311002	3\8			PI-317008	5\16		
PI-311302	1\2			PI-317010	3\8		
PI-311602	5\8			PI-317013	1\2		
PI-311902	3\4			PI-317016	5\8		
PI-312502	1"			PI-317019	3\4		
PI-313202	1"1\4			PI-317025	1"		
PI-313802	1"1\2						



ΜΑΣΤΟΙ INOX B.S.P

ΜΑΣΤΟΙ INOX N.P.T.				ΚΩΔΙΚΟΣ	ΠΕΡΙΓΡΑΦΗ	€	+ΦΠΑ
ΚΩΔΙΚΟΣ	ΠΕΡΙΓΡΑΦΗ	€	+ΦΠΑ				
PI-030606	1\4			PI-010303	1\8		
PI-031010	3\8			PI-010606	1\4		
PI-031313	1\2			PI-011010	3\8		
PI-031919	3\4			PI-011313	1\2		
PI-032525	1"			PI-011919	3\4		
				PI-012525	1"		
				PI-013232	1"1\4		
				PI-013838	1"1\2		



Με παξιμάδι κόντρα

ΚΟΝΤΡΑ INOX				ΚΩΔΙΚΟΣ	ΣΠΕΙΡΩΜΑ	€	+ΦΠΑ
ΚΩΔΙΚΟΣ	ΣΠΕΙΡΩΜΑ	€	+ΦΠΑ				
PI-090606	1\4			PI-060006	1\4		
PI-091010	3\8			PI-060010	3\8		
PI-091313	1\2			PI-060013	1\2		
PI-091919	3\4			PI-060019	3\4		
PI-092525	1"			PI-060025	1"		



ΤΑΦ Α-Α-Α B.S.P INOX



ΒΑΝΕΣ INOX 500 bar

ΚΩΔΙΚΟΣ	ΣΠΕΙΡΩΜΑ	€	+ΦΠΑ
PI-008001	1\4		
PI-008002	3\8		
PI-008003	1\2		



ΑΚΑΘΑΡΙΣΤΑ

ΚΥΑΘΙΑ INOX R1T- R2T			
PI-319006	1\4		
PI-319008	5\16		
PI-319010	3\8		
PI-319013	1\2		
PI-319016	5\8		
PI-319019	3\4		
PI-319025	1"		



ΜΟΥΦΑ INOX Θ-Θ BSP

ΚΩΔΙΚΟΣ	ΣΠΕΙΡΩΜΑ	€	+ΦΠΑ
PI-301202	1\4		
PI-301203	3\8		
PI-301204	1\2		
PI-301205	3\4		
PI-301206	1"		



ΜΑΣΤΟΙ B.S.P ΣΥΣΤΟΛΙΚΟΙ

ΚΩΔΙΚΟΣ	ΠΕΡΙΓΡΑΦΗ	€	+ΦΠΑ
PI-020306	1\8-1\4		
PI-020610	1\4-3\8		
PI-020613	1\4-1\2		
PI-021013	3\8-1\2		
PI-021319	1\2-3\4		
PI-021925	3\4-1"		



ΓΩΝΙΑ Α-Θ ΤΡΕΛΗ INOX

ΚΩΔΙΚΟΣ	ΣΠΕΙΡΩΜΑ	€	+ΦΠΑ
PI-306402	1\4		
PI-306403	3\8		
PI-306404	1\2		
PI-306406	3\4		
PI-306407	1"		



ΤΑΧΥΣΥΝΔΕΣΜΟΙ ΑΡΣΕΝΙΚΟΙ INOX

PI-008014	1\4		
PI-008010	3\8		
PI-008011	1\2		



ΤΑΧΥΣΥΝΔΕΣΜΟΙ ΘΗΛΥΚΟΙ INOX

PI-008209	1\4		
PI-008210	3\8		
PI-008211	1\2		



ΜΑΣΤΟΙ INOX B.S.P.

ΚΩΔΙΚΟΣ	ΣΙΔ/ΝΑ	ΒΑΣΗ	ΣΚΕΤΑ	ΚΟΜΠΛΕ	+ΦΠΑ
PI-000304	6L	1\8			
PI-000324	6L	1\4			
PI-000305	8L				
PI-000306	10L				
PI-000331	12L				
PI-000307	12L	3\8			
PI-000333	15L				
PI-000337	16S				
PI-000332	12L	1\2			
PI-000308	15L				
PI-000309	18L				
PI-000319	16S				
PI-000320	20S		3\4		



ΣΥΝΔΕΣΜΟΙ INOX

ΚΩΔΙΚΟΣ	ΣΙΔ/ΝΑ	ΣΚΕΤΑ	ΚΟΜΠΛΕ	+ΦΠΑ
PI-003504	6L			
PI-003505	8L			
PI-003506	10L			
PI-003507	12L			
PI-003508	15L			
PI-003509	18L			
PI-003519	16S			
PI-003520	20S			

ΤΑΦ Α-Α-Α INOX

ΚΩΔΙΚΟΣ	ΣΙΔ/ΝΑ	ΣΚΕΤΑ	ΚΟΜΠΛΕ	+ΦΠΑ
PI-003904	6L			
PI-003905	8L			
PI-003906	10L			
PI-003907	12L			
PI-003908	15L			
PI-003909	18L			
PI-003919	16S			
PI-003920	20S			



ΓΩΝΙΑ ΣΤΑΘΕΡΗ Α-Α INOX

ΚΩΔΙΚΟΣ	ΣΙΔ/ΝΑ	ΣΚΕΤΟ	ΚΟΜΠΛΕ	+ΦΠΑ
PI-003804	6L			
PI-003805	8L			
PI-003806	10L			
PI-003807	12L			
PI-003808	15L			
PI-003809	18L			
PI-003819	16S			
PI-003820	20S			



ΤΑΦ ΤΡΕΛΟ ΜΕΣΗ INOX

ΚΩΔΙΚΟΣ	ΣΙΔ/ΝΑ	ΣΚΕΤΟ	ΚΟΜΠΛΕ	+ΦΠΑ
PI-005004	6L			
PI-005005	8L			
PI-005006	10L			
PI-005007	12L			
PI-005008	15L			
PI-005009	18L			
PI-005019	16S			
PI-005020	20S			



ΓΩΝΙΕΣ ΤΡΕΛΜΕΣ Α-Θ INOX

ΚΩΔΙΚΟΣ	ΣΙΔ/ΝΑ	ΣΚΕΤΟ	ΚΟΜΠΛΕ	+ΦΠΑ
PI-004204	6L			
PI-004205	8L			
PI-004206	10L			
PI-004207	12L			
PI-004208	15L			
PI-004209	18L			
PI-004219	16S			
PI-004220	20S			



ΠΑΞΙΜΑΔΙΑ INOX

PI-000202	6LL			
PI-000204	6L			
PI-000205	8L			
PI-000206	10L			
PI-000207	12L			
PI-000208	15L			
PI-000209	18L			
PI-000210	22L			
PI-000214	6S			
PI-000219	16S			
PI-000220	20S			

ΜΠΙΜΠΙΚΙΑ INOX

PI-000102	6LL			
PI-000104	6L			
PI-000105	8L			
PI-000106	10L			
PI-000107	12L			
PI-000108	15L			
PI-000109	18L			
PI-000110	22L			
PI-000119	16S			
PI-000120	20S			



ΤΑΦ ΤΡΕΛΟ ΑΚΡΗ Α-Α-Θ INOX

ΚΩΔΙΚΟΣ	ΣΙΔ/ΝΑ	ΣΚΕΤΟ	ΚΟΜΠΛΕ	+ΦΠΑ
PI-004604	6L			
PI-004605	8L			
PI-004606	10L			
PI-004607	12L			
PI-004608	15L			
PI-004609	18L			
PI-004619	16S			
PI-004620	20S			



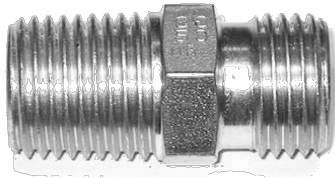

ΜΑΣΤΟΙ NPT-BSP CAST				ΜΑΣΤΟΙ BSP CAST				ΣΥΣΤΟΛΙΚΟΙ BSP CAST			
ΚΩΔΙΚΟΣ	ΣΠΕΙΡΩΜΑ	€	+ ΦΠΑ	ΚΩΔΙΚΟΣ	ΣΠΕΙΡΩΜΑ	€	+ ΦΠΑ	ΚΩΔΙΚΟΣ	ΣΠΕΙΡΩΜΑ	€	+ ΦΠΑ
PΣ-030303	1\8			PΣ-010303	1\8			PΣ-020306	1\8-1\4		
PΣ-030606	1\4			PΣ-010606	1\4			PΣ-020310	1\8-3\8		
PΣ-031010	3\8			PΣ-011010	3\8			PΣ-020610	1\4-3\8		
PΣ-031313	1\2			PΣ-011313	1\2			PΣ-020613	1\4-1\2		
PΣ-031919	3\4			PΣ-011616	5\8			PΣ-020619	1\4-3\4		
PΣ-032525	1"			PΣ-011919	3\4			PΣ-021013	3\8-1\2		
PΣ-033232	1" 1\4			PΣ-012525	1"			PΣ-021019	3\8-3\4		
PΣ-033838	1" 1\2			PΣ-013232	1" 1\4			PΣ-021316	1\2-5\8		
PΣ-035050	2"			PΣ-013838	1" 1\2			PΣ-021319	1\2-3\4		
				PΣ-015050	2"			PΣ-021325	1\2-1"		
								PΣ-021619	5\8-3\4		
								PΣ-021925	3\4-1"		
								PΣ-021932	3\4-1\4		
								PΣ-021938	3\4-1\2		
								PΣ-022532	1"-1\4		
								PΣ-022538	1"-1\2		
								PΣ-023238	1\4-1\2		
								PΣ-023250	1\4-2"		
								PΣ-023850	1\2-2"		



ΣΥΣΤΟΛΙΚΟΙ NPT-BSP			
ΚΩΔΙΚΟΣ	A - B	€	+ΦΠΑ
PΣ-030306	1/4-1/8		
PΣ-030610	3/8-1/4		
PΣ-031319	3/4-1/2		
PΣ-031925	1"- 3/4		
PΣ-030603	1/8-1/4		
PΣ-031006	1/4-3/8		
PΣ-031013	1/2-3/8		
PΣ-031310	3/8-1/2		
PΣ-031913	1/2-3/4		
PΣ-032519	3/4- 1"		



ΣΥΣΤΟΛΙΚΟΙ BSP f f

ΚΩΔΙΚΟΣ	ΣΠΕΙΡΩΜΑ	€	+ ΦΠΑ
PΣ-Φ20306	1\8-1\4		
PΣ-Φ20310	1\8-3\8		
PΣ-Φ20610	1\4-3\8		
PΣ-Φ20613	1\4-1\2		
PΣ-Φ20619	1\4-3\4		
PΣ-Φ21013	3\8-1\2		
PΣ-Φ21019	3\8-3\4		
PΣ-Φ21316	1\2-5\8		
PΣ-Φ21319	1\2-3\4		
PΣ-Φ21325	1\2-1"		
PΣ-Φ21619	5\8-3\4		
PΣ-Φ21925	3\4-1"		
PΣ-Φ21932	3\4-1\4		
PΣ-Φ21938	3\4-1\2		
PΣ-Φ22532	1"-1\4		
PΣ-Φ22538	1"-1\2		
PΣ-Φ23238	1\4-1\2		
PΣ-Φ23250	1\4-2"		
PΣ-Φ23850	1\2-2"		



ΜΑΣΤΟΙ 1mm τρύπα













Μαστοί με 1mm τρύπα για χρήση σε αγροτικά μηχ/τα ως στραγγαλιστές

ΚΩΔΙΚΟΣ	ΣΠΕΙΡΩΜΑ	€	+ ΦΠΑ
PΣ-010006	1\4		
PΣ-010010	3\8		

ΜΑΣΤΟΙ BSP f f

ΚΩΔΙΚΟΣ	ΣΠΕΙΡΩΜΑ	€	+ ΦΠΑ
PΣ-Φ10303	1\8		
PΣ-Φ10606	1\4		
PΣ-Φ11010	3\8		
PΣ-Φ11313	1\2		
PΣ-Φ11616	5\8		
PΣ-Φ11919	3\4		
PΣ-Φ12525	1"		
PΣ-Φ13232	1" 1\4		
PΣ-Φ13838	1" 1\2		
PΣ-Φ15050	2"		

 ΜΑΣΤΟΙ ΚΟΝΤΡΑ ΒSP				 ΠΑΞΙΜΑΔΙΑ ΚΟΝΤΡΑ				 ΓΩΝΙΕΣ Α-Α											
ΚΩΔΙΚΟΣ	ΣΠΕΙΡΩΜΑ	€	+ ΦΠΑ	ΚΩΔΙΚΟΣ	ΣΠΕΙΡΩΜΑ	€	+ ΦΠΑ	ΚΩΔΙΚΟΣ	ΣΠΕΙΡΩΜΑ	€	+ ΦΠΑ								
ΡΣ-090606	1\4			ΡΣ-140006	1\4			ΡΣ-050003	1\8										
ΡΣ-091010	3\8			ΡΣ-140010	3\8			ΡΣ-050006	1\4										
ΡΣ-091313	1\2			ΡΣ-140013	1\2			ΡΣ-050010	3\8										
ΡΣ-091616	5\8			ΡΣ-140019	3\4			ΡΣ-050013	1\2										
ΡΣ-091919	3\4			ΡΣ-140025	1"			ΡΣ-051613	1\2-5\8										
ΡΣ-092525	1"			ΡΣ-140012	12X1,5			ΡΣ-050019	3\4										
ΡΣ-093232	1" 1\4			ΡΣ-140014	14X1,5			ΡΣ-050025	1"										
 ΜΑΣΤΟΙ ΑΡΣ-ΘΗΛ				ΡΣ-140016	16X1,5			ΡΣ-050032	1" 1\4										
				ΡΣ-140018	18X1,5			ΡΣ-050038	1" 1\2										
				ΡΣ-140020	20X1,5			ΡΣ-050050	2"										
				ΡΣ-140022	22X1,5			 ΑΜΒΛΙΕΣ Α-Α											
 ΜΑΣΤΟΙ Θ-Θ				ΚΩΔΙΚΟΣ	ΣΠΕΙΡΩΜΑ	€	+ ΦΠΑ					ΚΩΔΙΚΟΣ	ΣΠΕΙΡΩΜΑ	€	+ ΦΠΑ				
				ΡΣ-070606	1\4							ΡΣ-302601	1\8						
				ΡΣ-071010	3\8							ΡΣ-302602	1\4						
				ΡΣ-071313	1\2			ΡΣ-302603	3\8										
ΡΣ-071616	5\8			ΡΣ-302604	1\2														
ΡΣ-071919	3\4			ΡΣ-302606	3\4														
ΡΣ-072525	1"			ΡΣ-302607	1"														
ΡΣ-073232	1" 1\4			 ΓΩΝΙΕΣ ΚΟΝΤΡΑ Β.S.P															
ΡΣ-073838	1" 1\2																		
ΡΣ-075050	2"																		
ΡΣ-070610	1\4-3\8																		
ΡΣ-070613	1\4-1\2			ΚΩΔΙΚΟΣ	ΣΠΕΙΡΩΜΑ	€	+ ΦΠΑ	ΚΩΔΙΚΟΣ	ΣΠΕΙΡΩΜΑ	€	+ ΦΠΑ								
ΡΣ-071006	3\8-1\4			ΡΣ-305401	1\8-1\8			ΡΣ-305402	1\8-1\4										
ΡΣ-071013	3\8-1\2			ΡΣ-305403	1\4-1\4			ΡΣ-305403	1\4-1\4										
ΡΣ-071306	1\2-1\4			ΡΣ-305404	1\4-3\8			ΡΣ-305404	1\4-3\8										
ΡΣ-071310	1\2-3\8			ΡΣ-305405	3\8-3\8			ΡΣ-305405	3\8-3\8										
ΡΣ-071316	1\2-5\8			ΡΣ-305406	3\8-1\2			ΡΣ-305406	3\8-1\2										
ΡΣ-071319	1\2-3\4			ΡΣ-305407	1\2-1\2			ΡΣ-305407	1\2-1\2										
ΡΣ-071613	5\8-1\2			ΡΣ-305408	1\2-3\4			ΡΣ-305408	1\2-3\4										
ΡΣ-071619	5\8-3\4			ΡΣ-305409	3\4-3\4			ΡΣ-305409	3\4-3\4										
ΡΣ-072207	7\8-1\4			ΡΣ-305410	3\4- 1"			ΡΣ-305410	3\4- 1"										
ΡΣ-072213	7\8-1\2			ΡΣ-305411	1" - 1"			ΡΣ-305411	1" - 1"										
ΡΣ-071913	3\4-1\2			ΡΣ-305413	1\4-1\4			ΡΣ-305413	1\4-1\4										
ΡΣ-071916	3\4-5\8			ΡΣ-305415	1\2-1\2			ΡΣ-305415	1\2-1\2										
ΡΣ-071925	3\4-1"			 ΓΩΝΙΕΣ Θ-Θ 90ο FF				 ΤΑΦ 1/4ΛΗΨΗΣ ΠΙΕΣΗΣ											
ΡΣ-072519	1" -3\4																		
 ΑΜΒΛΙΕΙΣ Α-Θ 45ο FF												ΚΩΔΙΚΟΣ	ΣΠΕΙΡΩΜΑ	€	+ ΦΠΑ	ΚΩΔΙΚΟΣ	ΣΠΕΙΡΩΜΑ	€	+ ΦΠΑ
												ΡΣ-160006	1\4			ΡΣ-005606	1\4		
				ΡΣ-160010	3\8			ΡΣ-005610	3\8										
				ΡΣ-160013	1\2			ΡΣ-005613	1\2										
ΡΣ-160019	3\4			ΡΣ-130606	1\4			ΡΣ-005619	3\4										
ΡΣ-160025	1"			ΡΣ-131010	3\8			ΡΣ-005625	1"										
 ΑΜΒΛΙΕΙΣ Θ-Θ 45ο FF				ΡΣ131313	1\2			ΡΣ-005622	αζωτου 21,8										
				ΡΣ-170006	1\4			ΡΣ-131919	3\4										
				ΡΣ-170010	3\8			ΡΣ-132525	1"										
				ΡΣ-170013	1\2														

**ΓΩΝΙΑ Α-Θ
ΣΤΑΘΕΡΗ****ΓΩΝΙΑ Θ-Θ
ΣΤΑΘΕΡΗ**

CAST

ΚΩΔΙΚΟΣ	ΣΠΕΙΡΩΜΑ	€	+ ΦΠΑ	ΚΩΔΙΚΟΣ	ΣΠΕΙΡΩΜΑ	€	+ ΦΠΑ
PΣ-303801	1/8			PΣ-304201	1/8		
PΣ-303802	1/4			PΣ-304202	1/4		
PΣ-303803	3/8			PΣ-304203	3/8		
PΣ-303804	1/2			PΣ-304204	1/2		
PΣ-303806	3/4			PΣ-304206	3/4		
PΣ-303807	1"			PΣ-304207	1"		
PΣ-303817	1" 1/4			PΣ-304208	1" 1/4		
				PΣ-304209	1" 1/2		

ΓΩΝΙΑ Α-Θ ΤΡΕΛΛΗ

ΚΩΔΙΚΟΣ	ΣΠΕΙΡΩΜΑ	€	+ ΦΠΑ
PΣ-306401	1/8		
PΣ-306402	1/4		
PΣ-306403	3/8		
PΣ-306404	1/2		
PΣ-306405	5/8		
PΣ-306406	3/4		
PΣ-306407	1"		
PΣ-306408	1" 1/4		
PΣ-306409	1" 1/2		
PΣ-306410	2"		

**ΤΑΦ Α-Α-Α
BSP****ΤΑΦ Θ-Θ-Θ
BSP**

ΚΩΔΙΚΟΣ	ΣΠΕΙΡΩΜΑ	€	+ ΦΠΑ	ΚΩΔΙΚΟΣ	ΣΠΕΙΡΩΜΑ	€	+ ΦΠΑ
PΣ-060003	1/8			PΣ-305001	1/8		
PΣ-060006	1/4			PΣ-305002	1/4		
PΣ-060010	3/8			PΣ-305003	3/8		
PΣ-060013	1/2			PΣ-305004	1/2		
PΣ-060016	5/8			PΣ-305006	3/4		
PΣ-060019	3/4			PΣ-305007	1"		
PΣ-060025	1"			PΣ-305008	1" 1/4		
PΣ-060032	1" 1/4			PΣ-305009	1" 1/2		
PΣ-060038	1" 1/2			PΣ-305010	2"		
PΣ-060050	2"						

**ΤΑΦ ΤΡΕΛΜΟ ΜΕΣΗ**

ΚΩΔΙΚΟΣ	ΣΠΕΙΡΩΜΑ	€	+ ΦΠΑ
PΣ-306801	1/8		
PΣ-306802	1/4		
PΣ-306803	3/8		
PΣ-306804	1/2		
PΣ-306806	3/4		
PΣ-306807	1"		

**ΤΑΦ Α-Α-Α
ακρη NPT****ΤΑΦ Α-θ-θ
ακρη NPT**

ΚΩΔΙΚΟΣ	ΣΠΕΙΡΩΜΑ	€	+ ΦΠΑ	ΚΩΔΙΚΟΣ	ΣΠΕΙΡΩΜΑ	€	+ ΦΠΑ
PΣ-303006	1/4			PΣ-304801	1/8		
PΣ-303010	3/8			PΣ-304802	1/4		
PΣ-303013	1/2			PΣ-304803	3/8		
PΣ-303019	3/4			PΣ-304804	1/2		
PΣ-303025	1"			PΣ-304806	3/4		
				PΣ-304807	1"		

**ΤΑΦ ΤΡΕΛΜΟ ΑΚΡΗ**

ΚΩΔΙΚΟΣ	ΣΠΕΙΡΩΜΑ	€	+ ΦΠΑ
PΣ-306601	1/8		
PΣ-306602	1/4		
PΣ-306603	3/8		
PΣ-306604	1/2		
PΣ-306606	3/4		
PΣ-306607	1"		
PΣ-306608	1" 1/4		

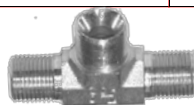
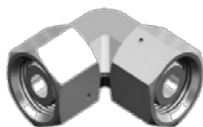
**ΤΑΦ Α-Α-Α
μέση NPT****ΓΩΝΙΑ Θ-Θ
ΤΡΕΛΛΗ**

ΚΩΔΙΚΟΣ	ΣΠΕΙΡΩΜΑ	€	+ ΦΠΑ	ΚΩΔΙΚΟΣ	ΣΠΕΙΡΩΜΑ	€	+ ΦΠΑ
PΣ-303206	1/4			PΣ-306430	1/8		
PΣ-303210	3/8			PΣ-306431	1/4		
PΣ-303213	1/2			PΣ-306432	3/8		
PΣ-303219	3/4			PΣ-306433	1/2		
PΣ-303225	1"			PΣ-306434	3/4		
				PΣ-306435	1"		

**ΤΑΦ Θ-Θ-Θ
ΤΡΕΛΜΟ BSP**

ΚΩΔΙΚΟΣ	ΣΠΕΙΡΩΜΑ	€	+ ΦΠΑ
PΣ-306631	1/4		
PΣ-306632	3/8		
PΣ-306633	1/2		
PΣ-306634	3/4		
PΣ-306635	1"		

**ΤΑΦ Θ-Α-θ
μέση NPT****ΑΜΒΛΙΑ Α-θ
ΤΡΕΛΛΗ**

ΚΩΔΙΚΟΣ	ΣΠΕΙΡΩΜΑ	€	+ ΦΠΑ	ΚΩΔΙΚΟΣ	ΣΠΕΙΡΩΜΑ	€	+ ΦΠΑ
PΣ-304601	1/8			PΣ-308201	1/4		
PΣ-304602	1/4			PΣ-308203	3/8		
PΣ-304603	3/8			PΣ-308204	1/2		
PΣ-304604	1/2			PΣ-308206	3/4		
PΣ-304605	3/4			PΣ-308207	1"		
PΣ-304606	1"						



ΤΑΠΕΣ ALLEN B.S.P. Ο/R				ΤΑΠΕΣ ALLEN ΜΕΤΡΙΚΕΣ Ο/R				ΤΑΠΕΣ ΑΚΕΦΑΛΕΣ ALLEN			
ΚΩΔΙΚΟΣ	ΣΠΕΙΡΩΜΑ	€	+ ΦΠΑ	ΚΩΔΙΚΟΣ	ΣΠΕΙΡΩΜΑ	€	+ ΦΠΑ	ΚΩΔΙΚΟΣ	ΣΠΕΙΡΩΜΑ	€	+ ΦΠΑ
ΡΣ-007601	1\8			ΡΣ-007700	8X1			ΡΣ-301001	1\8		
ΡΣ-007602	1\4			ΡΣ-007701	10X1			ΡΣ-301002	1\4		
ΡΣ-007603	3\8			ΡΣ-007702	12X1,5			ΡΣ-301003	3\8		
ΡΣ-007604	1\2			ΡΣ-007703	14X1,5			ΡΣ-301004	1\2		
ΡΣ-007605	3\4			ΡΣ-007704	16X1,5			ΡΣ-301005	3\4		
ΡΣ-007606	1"			ΡΣ-007705	18X1,5			ΡΣ-301006	1"		
ΡΣ-007607	1 1\4			ΡΣ-007706	20X1,5						
ΡΣ-007608	1" 1\2			ΡΣ-007707	22X1,5						



**ΕΞΑΓΩΝΟ
& ΕΔΡΑ
ΓΙΑ ΜΠΙΜΠΙΚΙ**

ΤΑΠΕΣ ΜΕΤΡΙΚΕΣ ΕΔΡΑ 24°

ΚΩΔΙΚΟΣ	ΣΠΕΙΡΩΜΑ	€	+ ΦΠΑ
ΡΣ-007900	10X1		
ΡΣ-007920	12X1,5-6L		
ΡΣ-007921	14X1,5-8L		
ΡΣ-007904	14X1,5-6S		
ΡΣ-007922	16X1,5-10L		
ΡΣ-007905	16X1,5-8S		
ΡΣ-007923	18X1,5-12L		
ΡΣ-007906	18X1,5-10S		
ΡΣ-007924	20X1,5-12S		
ΡΣ-007925	22X,15-15L		
ΡΣ-007913	22X,15-14S		
ΡΣ-007926	24X1,5-16S		
ΡΣ-007927	26X1,5-18L		
ΡΣ-007928	30X2-20S		
ΡΣ-007929	30X2-22L		
ΡΣ-007914	30X1,5		
ΡΣ-007915	36X1,5		
ΡΣ-007909	36X2-25S		
ΡΣ-007910	42X2-30S		
ΡΣ-007911	45X2-35L		
ΡΣ-007912	52X2-38S		

ΡΣ-007713	24X1,5		
ΡΣ-007708	26X1,5		
ΡΣ-007709	27X2		
ΡΣ-007726	30X1,5		
ΡΣ-007710	33X2		
ΡΣ-007711	42X2		
ΡΣ-007712	48X2		



ΤΑΠΕΣ BSP εξάγωνες

ΚΩΔΙΚΟΣ	ΣΠΕΙΡΩΜΑ	€	+ ΦΠΑ
ΡΣ-007801	1\8		
ΡΣ-007802	1\4		
ΡΣ-007803	3\8		
ΡΣ-007804	1\2		
ΡΣ-007805	5\8		
ΡΣ-007806	3\4		
ΡΣ-007807	1"		
ΡΣ-007808	1 1\4		
ΡΣ-007809	1" 1\2		
ΡΣ-007810	2"		

ΤΑΠΕΣ ΘΗΛΥΚΕΣ

ΚΩΔΙΚΟΣ	ΣΠΕΙΡΩΜΑ	€	+ ΦΠΑ
ΡΣ-005804	6L-S		
ΡΣ-005805	8L-S		
ΡΣ-005806	10L-S		
ΡΣ-005807	12L-S		
ΡΣ-005808	15L		
ΡΣ-005809	18L		
ΡΣ-005810	22L		
ΡΣ-005811	28L		
ΡΣ-005812	35L		
ΡΣ-005813	42L		
ΡΣ-005818	14S		
ΡΣ-005819	16S		
ΡΣ-005820	20S		
ΡΣ-005821	25S		
ΡΣ-005822	30S		
ΡΣ-005823	38S		



ΜΟΥΦΑ ΚΟΛΛΗΤΗ

ΚΩΔΙΚΟΣ	ΣΠΕΙΡΩΜΑ	€	+ ΦΠΑ
ΡΣ-030006	1\4		
ΡΣ-030010	3\8		
ΡΣ-030013	1\2		
ΡΣ-030019	3\4		
ΡΣ-030025	1"		



ΜΑΣΤΟΙ ΚΟΛΛΗΤΟΙ

ΚΩΔΙΚΟΣ	ΣΠΕΙΡΩΜΑ	€	+ ΦΠΑ
ΡΣ-070006	1\4		
ΡΣ-070010	3\8		
ΡΣ-070013	1\2		
ΡΣ-070019	3\4		
ΡΣ-070025	1"		
ΡΣ-070032	1 1\4		
ΡΣ-070018	18 X1,5		
ΡΣ-070022	22X1,5		
ΡΣ-070026	26X1,5		

ΤΑΠΕΣ ΘΗΛΥΚΕΣ B.S.P

ΚΩΔΙΚΟΣ	ΣΠΕΙΡΩΜΑ	€	+ ΦΠΑ
ΡΣ-005701	1\8		
ΡΣ-005702	1\4		
ΡΣ-005703	3\8		
ΡΣ-005704	1\2		
ΡΣ-005705	5\8		
ΡΣ-005706	3\4		
ΡΣ-005707	1"		
ΡΣ-005708	1 1\4		
ΡΣ-005709	1" 1\2		
ΡΣ-005710	2"		



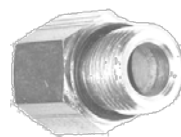

ΜΟΥΦΑ Θ-Θ B.S.P.				ΣΥΣΤΟΛΕΣ ΑΜΕΡΙΚΗΣ				ΣΥΣΤΟΛΕΣ ΑΓΓΛΙΑΣ			
ΚΩΔΙΚΟΣ	ΣΠΕΙΡΩΜΑ	€	+ ΦΠΑ	ΚΩΔΙΚΟΣ	ΣΠΕΙΡΩΜΑ	€	+ ΦΠΑ	ΚΩΔΙΚΟΣ	ΣΠΕΙΡΩΜΑ	€	+ ΦΠΑ
PΣ-301201	1/8			PΣ-007400	1/4-1/8			PΣ-007501	1/8-1/4		
PΣ-301202	1/4			PΣ-007401	3/8-1/8			PΣ-007502	1/8-3/8		
PΣ-301203	3/8			PΣ-007414	3/8-1/4			PΣ-007503	1/4-1/8		
PΣ-301204	1/2			PΣ-007402	1/2-1/8			PΣ-007504	1/4-3/8		
PΣ-301205	3/4			PΣ-007403	1/2-1/4			PΣ-007505	1/4-1/2		
PΣ-301206	1"			PΣ-007415	1/2-3/8			PΣ-007506	1/4-3/4		
PΣ-301207	1"1/4			PΣ-007404	3/4-1/4			PΣ-007507	3/8-1/4		
PΣ-301208	1"1/2			PΣ-007405	3/4-3/8			PΣ-007508	3/8-1/2		
PΣ-301209	1/4-1/8			PΣ-007406	3/4-1/2			PΣ-007509	3/8-3/4		
PΣ-301211	3/8-1/4			PΣ-007408	1"-1/2			PΣ-007510	1/2-3/8		
PΣ-301212	1/2-1/4			PΣ-007409	1"-3/4			PΣ-007511	1/2-3/4		
PΣ-301214	1/2-3/8			PΣ-007410	1/4 - 3/4			PΣ-007512	1/2-1"		
PΣ-301215	3/4-1/2			PΣ-007412	1/2 - 3/4			PΣ-007514	3/4-1/2		

ΜΟΥΦΑ	Θ-Θ ΜΕΤΡΙΚΕΣ	€	+ ΦΠΑ
PΣ-301300	10X1		
PΣ-301301	12X1,5		
PΣ-301302	14X1,5		
PΣ-301303	16X1,5		
PΣ-301305	18X1,5		
PΣ-301306	20X1,5		
PΣ-301304	22X1,5		
PΣ-301308	24X1,5		
PΣ-301307	26X1,5		

ΚΩΔΙΚΟΣ	ΔΙΑΣΤΑΣΗ	€	+ ΦΠΑ
PΣ-007413	1/2 - 1"		
PΣ-007417	2"-1/4		
PΣ-007418	2"-1/2		



ΚΩΔΙΚΟΣ	ΣΠΕΙΡΩΜΑ	€	+ ΦΠΑ
PΣ-007515	3/4-1"		
PΣ-007518	1"-3/4		
PΣ-007519	1"- 1/4		
PΣ-007520	1"-1/2		
PΣ-007521	1/4-1"		
PΣ-007522	1/4 - 1/2		
PΣ-007523	1/2 - 1/4		

ΡΟΔΕΛΕΣ ΟΡ/ΝΕΣ

ΚΩΔΙΚΟΣ	ΔΙΑΣΤΑΣΗ	€	+ ΦΠΑ
ΕΕ-100013	1/4 1,5mm		
ΕΕ-100017	3/8 1,5mm		
ΕΕ-100021	1/2 1,5mm		
ΕΕ-100023	5/8 1,5mm		
ΕΕ-100027	3/4 1,5mm		
ΕΕ-100019	3/4 3mm		
ΕΕ-100033	1" 1,5mm		
ΕΕ-100025	1" 3mm		
ΕΕ-100032	1"1/4 3mm		
ΕΕ-100038	1"1/2 3mm		
ΕΕ-100050	2" 3mm		
ΕΕ-100006	6 1,5mm		
ΕΕ-100008	8 1,5mm		
ΕΕ-100010	10 1,5mm		
ΕΕ-100012	12 1,5mm		
ΕΕ-100014	14 1,5mm		
ΕΕ-100016	16 1,5mm		
ΕΕ-100018	18 1,5mm		
ΕΕ-100020	20 1,5mm		
ΕΕ-100022	22 1,5mm		
ΕΕ-100024	24 1,5mm		
ΕΕ-100026	26 1,5mm		
ΕΕ-100030	30 1,5mm		

ΡΟΔΕΛΕΣ ΜΕ Ο/R BSP

ΚΩΔΙΚΟΣ	ΣΠΕΙΡΩΜΑ	€	+ ΦΠΑ
ΕΕ-110013	1/4		
ΕΕ-110017	3/8		
ΕΕ-110021	1/2		
ΕΕ-110023	5/8		
ΕΕ-110019	3/4		
ΕΕ-110025	1"		
ΕΕ-110032	1"1/4		
ΕΕ-110038	1"1/2		
ΕΕ-110050	2"		

ΠΡΟΕΚΤΑΣΕΙΣ ΑΡΣ.-ΘΗΛ.

ΚΩΔΙΚΟΣ	ΣΠΕΙΡΩΜΑ	€	+ ΦΠΑ
PΣ-040003	1/8 L20		
PΣ-040006	1/4 L20		
PΣ-040010	3/8 L20		
PΣ-040013	1/2 L25		
PΣ-040019	3/4 L30		
PΣ-040025	1" L35		
PΣ-044510	3/8 L45		
PΣ-044513	1/2 L45		

ΡΟΔΕΛΕΣ ΑΕΡΟΦΡΕΝΩΝ ροδέλα χάλκινη με πατούρα + Ο/R



ΚΩΔΙΚΟΣ	ΔΙΑΣΤΑΣΗ	€	+ ΦΠΑ
PΦ-100001	12mm		
PΦ-100002	14mm		
PΦ-100003	16mm		
PΦ-100004	18mm		
PΦ-100005	22mm		



ΑΝΤΕΠΙΣΤΡΟΦΕΣ ΒΑΛΒΙΔΕΣ ΛΑΔΙΟΥ

400 BAR (0,4 - +0,7 BAR)

ΚΩΔΙΚΟΣ	ΔΙΑΣΤΑΣΗ	€	+ ΦΠΑ
ΡΣ-007007	1\4		
ΡΣ-007008	3\8		
ΡΣ-007009	1\2		
ΡΣ-007010	3\4		
ΡΣ-007011	1"		



ΒΑΛΒΙΔΑ ΛΗΨΗΣ ΠΙΕΣΗΣ I.S.M

16Χ2 ΑΡΣΕΝΙΚΟ

ΚΩΔΙΚΟΣ	ΔΙΑΣΤΑΣΗ	€	+ ΦΠΑ
ΜΤ-000007	1\8		
ΜΤ-000008	1\4		
ΜΤ-000027	3\8		
ΜΤ-000013	8Χ1		
ΜΤ-000009	10Χ1		
ΜΤ-000040	10Χ1,25		
ΜΤ-000010	12Χ1,5		
ΜΤ-000011	14Χ1,5		
ΜΤ-000020	7\16		
ΜΤ-000021	9\16		



I.S.M 16Χ2 ΜΕ RZ

ΚΩΔΙΚΟΣ	ΔΙΑΣΤΑΣΗ	€	+ ΦΠΑ
ΜΤ-000015	6 L-S		
ΜΤ-000016	8 L-S		
ΜΤ-000017	10 L-S		
ΜΤ-000018	12 L-S		



ΚΟΝΤΡΑ 16Χ2 -ΘΗΛ 1/4 ΜΑΝΟΜΕΤΡΟΥ

ΚΩΔΙΚΟΣ	ΔΙΑΣΤΑΣΗ	€	+ ΦΠΑ
ΜΤ-000026	A16Χ2-1\4		



ΘΗΛ.16Χ2 -ΘΗΛ 1/4 ΜΑΝΟΜΕΤΡΟΥ

ΚΩΔΙΚΟΣ	ΔΙΑΣΤΑΣΗ	€	+ ΦΠΑ
ΜΤ-000019	Θ16Χ2-1\4		



ΠΕΡΙΣΤΡΕΦΟΜΕΝΑ ΙΣΙΑ

ΚΩΔΙΚΟΣ	ΔΙΑΣΤΑΣΗ	€	+ ΦΠΑ
ΡΣ-007015	1\4		
ΡΣ-007016	3\8		
ΡΣ-007017	1\2		
ΡΣ-007018	3\4		
ΡΣ-007019	1"		
ΡΣ-007020	1" 1\4		
ΡΣ-007021	1" 1\2		

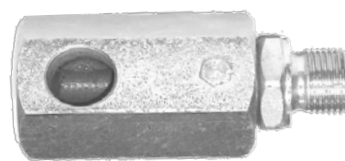

ΠΕΡΙΣΤΡΕΦΟΜΕΝΑ ΓΩΝΙΕΣ

ΚΩΔΙΚΟΣ	ΔΙΑΣΤΑΣΗ	€	+ ΦΠΑ
ΡΣ-007023	1\4		
ΡΣ-007024	3\8		
ΡΣ-007025	1\2		
ΡΣ-007026	3\4		
ΡΣ-007027	1"		
ΡΣ-007028	1" 1\4		
ΡΣ-007029	1" 1\2		

MICROTUBI ΜΕΤΡΗΣΗΣ ΠΙΕΣΗΣ

630 bar w.p.



ΜΕ ΘΗΛΥΚΑ 16Χ2

ΚΩΔΙΚΟΣ	ΔΙΑΣΤΑΣΗ	€	+ ΦΠΑ
ΠΠ-000116	1 m		
ΠΠ-001516	1,5m		
ΠΠ-000216	2m		
ΠΠ-002516	2,5m		
ΠΠ-000316	3m		

ΘΗΛ. 16Χ2-Θ1/4μανομέτρου

ΚΩΔΙΚΟΣ	ΔΙΑΣΤΑΣΗ	€	+ ΦΠΑ
ΠΠ-000106	1 m		
ΠΠ-001506	1,5m		
ΠΠ-000206	2m		
ΠΠ-002606	2,5m		
ΠΠ-000306	3m		

Κατασκευάζονται σε διάφορα μήκη.

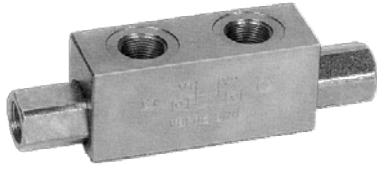
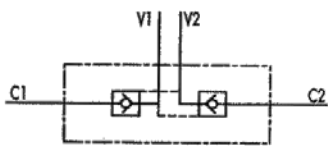

ΒΑΛΒΙΔΕΣ ΚΛΕΙΔΩΜΑΤΟΣ ΔΙΠΛΗΣ ΕΝΕΡΓΕΙΑΣ

Double pilot check valves

Ατσάλινες

ΚΩΔΙΚΟΣ	είσοδος	Pilot ratio	ΠΑΡΟΧΗ Lit/min	bar max	bar έναρξης	€	€
	έξοδος						+ΦΠΑ
ΥΔ-100006	1/4	1:5,5	20	350	4		
ΥΔ-100010	3/8	1:5,5	35	350	3		
ΥΔ-100013	1/2	1:5	50	350	3		
ΥΔ-100018	3/4	1:5	100	300	2		
ΥΔ-100618	1/4-18X1.5	1:5,5	35	350	3		
ΥΔ-101018	3/8-18X1.5	1:5,5	35	350	3		

ΒΑΛΒΙΔΕΣ ΚΛΕΙΔΩΜΑΤΟΣ ΔΙΠΛΗΣ ΕΝΕΡΓΕΙΑΣ

με χειροκίνητο κλείσιμο για ποδαρικά

Ατσάλινες

Double pilot check valves with manual shut off

ΧΕΡΟΥΛΙ ΔΕΞΙ

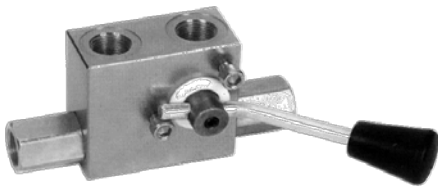
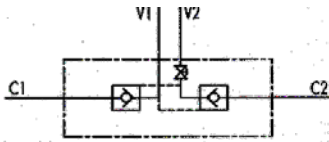

ΚΩΔΙΚΟΣ	είσοδος	Pilot ratio	ΠΑΡΟΧΗ Lit/min	bar max	bar έναρξης	€	€
	έξοδος						+ΦΠΑ
ΥΔ-110006	1/4	1:5,5	20	350	4		
ΥΔ-110010	3/8	1:5,5	30	350	3		
ΥΔ-110013	1/2	1:5	50	350	3		

ΧΕΡΟΥΛΙ ΑΡΙΣΤΕΡΟ

ΚΩΔΙΚΟΣ	είσοδος	Pilot ratio	ΠΑΡΟΧΗ Lit/min	bar max	bar έναρξης	€	€
	έξοδος						+ΦΠΑ
ΥΔ-110106	1/4	1:5,5	20	350	4		
ΥΔ-110110	3/8	1:5,5	30	350	3		
ΥΔ-110113	1/2	1:5	50	350	3		

ΒΑΛΒΙΔΕΣ ΡΥΘΜΙΣΗΣ ΚΛΕΙΔΩΜΑΤΟΣ ΜΟΝΕΣ

overcenter valves (ομαλή παροχή στο κατέβασμα)

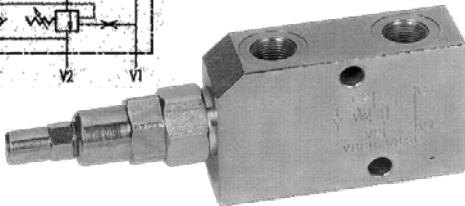
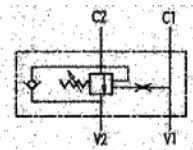

ΚΩΔΙΚΟΣ	είσοδος	Pilot ratio	ΠΑΡΟΧΗ Lit/min	bar max	€	€
	έξοδος					+ΦΠΑ
ΥΔ-120010	3/8	1:3,1	35	350		
ΥΔ-120013	1/2	1:5	70	350		
ΥΔ-120019	3/4	1:5,5	105	350		

Ατσάλινες

ΒΑΛΒΙΔΕΣ ΡΥΘΜΙΣΗΣ ΚΛΕΙΔΩΜΑΤΟΣ ΔΙΠΛΗΣ

double overcenter valves (ομαλή παροχή στο κατέβασμα)

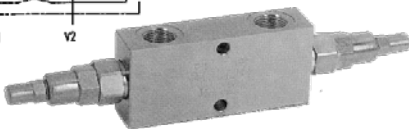
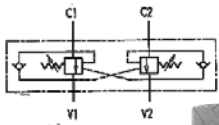

ΚΩΔΙΚΟΣ	είσοδος	Pilot ratio	ΠΑΡΟΧΗ Lit/min	bar max	€	€
	έξοδος					+ΦΠΑ
ΥΔ-130010	3/8	1:3,1	35	350		
ΥΔ-130013	1/2	1:5	70	350		
ΥΔ-130019	3/4	1:5,5	105	350		

Ατσάλινες

ΒΑΛΒΙΔΕΣ ΣΤΑΘΕΡΟΠΟΙΗΣΗΣ ΠΑΡΟΧΗΣ

ΡΥΘΜΙΖΟΜΕΝΕΣ

sequence valves

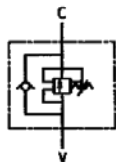

ΚΩΔΙΚΟΣ	είσοδος	ΠΑΡΟΧΗ Lit/min	bar max	€	€
	έξοδος				+ΦΠΑ
ΥΔ-140010	3/8	35	250		
ΥΔ-140013	1/2	70	250		

ΔΙΑΧΩΡΙΣΤΕΣ ΡΥΘΜΙΖΟΜΕΝΗΣ ΡΟΗΣ ΤΡΙΟΔΗ

3port flow control valve on going pressure line

Ατσάλινες

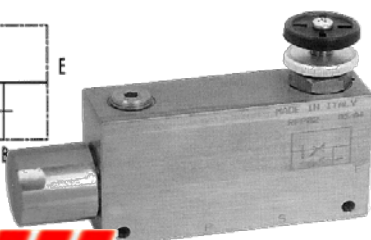
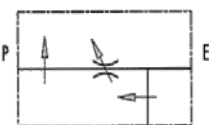

ΚΩΔΙΚΟΣ	είσοδος	in	ΡΥΘΜ	bar max	€	€
	έξοδος	l/min	l/min			+ΦΠΑ
ΥΔ-150010	3/8	50	40	250		
ΥΔ-150013	1/2	85	60	250		



made in Italy

ΚΑΤΑΝΕΜΗΤΕΣ ΕΝΑΛΛΑΓΗΣ ΜΕ ΜΠΙΛΙΑ

shuttle valves

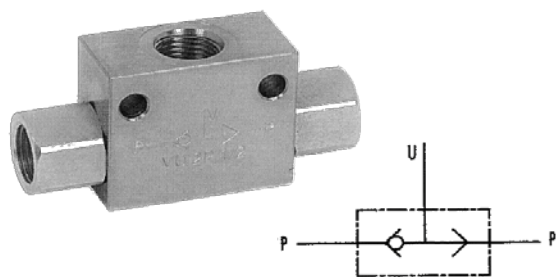

ΚΩΔΙΚΟΣ	είσοδος	Pilot ratio	ΠΑΡΟΧΗ Lit/min	bar	bar	€	€
	έξοδος			max	έναρξης		+ΦΠΑ
ΥΔ-160006	1/4	1:5,5	20	350	4		
ΥΔ-160010	3/8	1:5,5	35	350	3		
ΥΔ-160013	1/2	1:5	50	350	3		
ΥΔ-160014	1/2	1:5	70	350	3,5		
ΥΔ-160019	3/4	1:5	100	300	2		

ΒΑΛΒΙΔΕΣ ΦΡΑΓΜΟΥ - ΘΡΑΥΣΕΩΣ (ΑΛΕΞΙΠΤΩΤΑ)

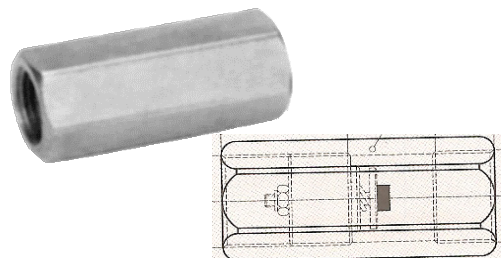

ΚΩΔΙΚΟΣ	είσοδος	ΠΑΡΟΧΗ Lit/min	bar	bar	€	€
	έξοδος		max	έναρξης		+ΦΠΑ
ΥΔ-170006	1/4	20	350	0,5		
ΥΔ-170010	3/8	45	350	0,5		
ΥΔ-170013	1/2	70	350	0,5		
ΥΔ-170019	3/4	110	350	0,5		
ΥΔ-170025	1"	160	300	0,5		

ΣΤΡΑΓΓΑΛΙΣΤΕΣ (ΒΑΡΕΛΑΚΙΑ) ΜΕ ΑΝΤΕΠΙΣΤΡΟΦΗ

Barrel flow control valve with check.

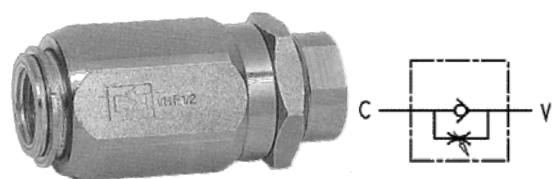

ΚΩΔΙΚΟΣ	είσοδος	ΠΑΡΟΧΗ Lit/min	bar	bar	€	€
	έξοδος		max	έναρξης		+ΦΠΑ
ΥΔ-180006	1/4	20	350	0,5		
ΥΔ-180010	3/8	45	350	0,5		
ΥΔ-180013	1/2	70	350	0,5		
ΥΔ-180019	3/4	110	350	0,5		
ΥΔ-180025	1"	160	300	0,5		

ΣΤΡΑΓΓΑΛΙΣΤΕΣ (ΒΑΡΕΛΑΚΙΑ) ΧΩΡΙΣ ΑΝΤΕΠΙΣΤΡΟΦΗ

Barrel flow control valve no check.

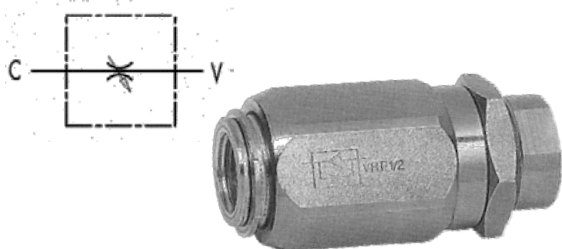

ΚΩΔΙΚΟΣ	είσοδος	ΠΑΡΟΧΗ Lit/min	bar	bar	€	€
	έξοδος		max	έναρξης		+ΦΠΑ
ΥΔ-190006	1/4	20	350	0,5		
ΥΔ-190010	3/8	45	350	0,5		
ΥΔ-190013	1/2	70	350	0,5		
ΥΔ-190019	3/4	110	350	0,5		
ΥΔ-190025	1"	160	300	0,5		

ΡΥΘΜΙΣΤΕΣ ΡΟΗΣ ΜΕ ΑΡΙΘΜΗΣΗ & ΑΝΤΕΠΙΣΤΡΟΦΗ

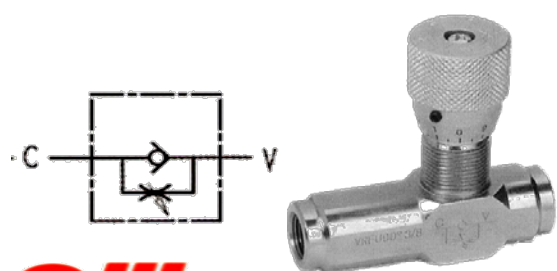

ΚΩΔΙΚΟΣ	είσοδος	ΠΑΡΟΧΗ Lit/min	bar	bar	€	€
	έξοδος		max	έναρξης		+ΦΠΑ
ΥΔ-200006	1/4	15	350	0,5		
ΥΔ-200010	3/8	30	350	0,5		
ΥΔ-200013	1/2	50	350	0,5		
ΥΔ-200019	3/4	60	280	0,5		

ΡΥΘΜΙΣΤΕΣ ΡΟΗΣ με ΑΡΙΘΜΗΣΗ χωρίς ΑΝΤΕΠΙΣΤΡΟΦΗ

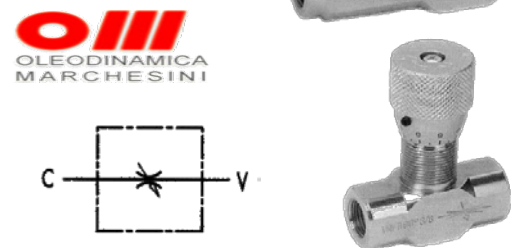

ΚΩΔΙΚΟΣ	είσοδος	ΠΑΡΟΧΗ Lit/min	bar	bar	€	€
	έξοδος		max	έναρξης		+ΦΠΑ
ΥΔ-210006	1/4	15	350	0,5		
ΥΔ-210010	3/8	30	350	0,5		
ΥΔ-210013	1/2	50	350	0,5		
ΥΔ-210019	3/4	80	280	0,5		

ΒΑΛΒΙΔΑ ΤΕΡΜΑΤΙΚΗ ΔΙΑΚΟΠΗΣ ΠΑΡΟΧΗΣ ανοικτή

END STROKE VALVES, NORMALLY OPENED



ΚΩΔΙΚΟΣ	είσοδος	ΠΑΡΟΧΗ Lit/min	bar	€	€
	έξοδος		max		+ΦΠΑ
ΥΔ-220010	3/8	60	350		
ΥΔ-220013	1/2	80	350		
ΥΔ-220019	3/4	120	350		

Η βαλβίδα κλείνει όταν έλκουμε ή πιέζουμε τον σύρτη.



ΒΑΛΒΙΔΑ ΤΕΡΜΑΤΙΚΗ ΔΙΑΚΟΠΗΣ ΠΑΡΟΧΗΣ κλειστή

END STROKE VALVES, NORMALLY CLOSED

ΚΩΔΙΚΟΣ	είσοδος	ΠΑΡΟΧΗ	bar	€	€
	έξοδος		Lit/min		max
ΥΔ-230010	3/8	60	350		
ΥΔ-230013	1/2	80	350		
ΥΔ-230019	3/4	120	350		

Η βαλβίδα ανοίγει όταν έλκουμε ή πιέζουμε τον σύρτη.

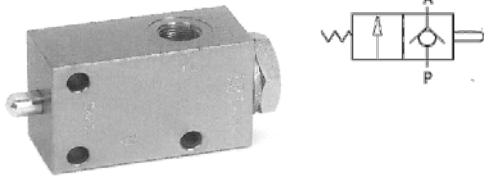

ΤΕΡΜΑΤΙΚΗ ΔΙΑΚΟΠΗΣ ΠΑΡΟΧΗΣ κλειστή με έμβολο

PUSHBUTTON END STROKE VALVES, NORMALLY CLOSED

ΚΩΔΙΚΟΣ	είσοδος	ΠΑΡΟΧΗ	bar	€	€
	έξοδος		Lit/min		max
ΥΔ-240010	3/8	40	350		
ΥΔ-240013	1/2	60	350		
ΥΔ-240019	3/4	100	350		

Η βαλβίδα ανοίγει πιέζοντας το εμβολάκι

OIII
OLEODINAMICA
MARCHESINI

made in Italy

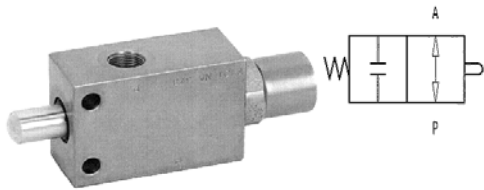

ΤΕΡΜΑΤΙΚΗ ΔΙΑΚΟΠΗΣ ΠΑΡΟΧΗΣ ανοικτή με έμβολο

PUSHBUTTON END STROKE VALVES, NORMALLY OPENED

ΚΩΔΙΚΟΣ	είσοδος	ΠΑΡΟΧΗ	bar	€	€
	έξοδος		Lit/min		max
ΥΔ-250010	3/8	35	350		
ΥΔ-250013	1/2	50	350		

Η βαλβίδα κλείνει πιέζοντας το εμβολάκι

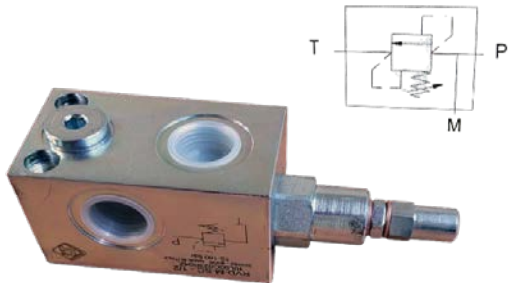

ΒΑΛΒΙΔΕΣ ΠΥΘΟΜΙΣΗΣ RELIEF VALVES

ΚΩΔΙΚΟΣ	είσοδος	ΠΑΡΟΧΗ	bar	€	€
	έξοδος		Lit/min		max
ΥΔ-300010	3/8	45	180		
ΥΔ-300013	1/2	70	180		
ΥΔ-300019	3/4	70	180		

ΒΑΝΕΣ ΜΑΝΤΕΜΕΝΙΕΣ ΤΡΙΟΔΕΣ ανοικτό κεντρο

ΚΩΔΙΚΟΣ	είσοδος	ΠΑΡΟΧΗ	bar	€	€
	έξοδος		Lit/min		max
ΥΔ-260010	3/8	35	250		
ΥΔ-260013	1/2	60	250		
ΥΔ-260019	3/4	100	250		



ΒΑΝΕΣ ΜΑΝΤΕΜΕΝΙΕΣ ΤΕΤΡΑΟΔΕΣ ανοικτό κεντρο

ΚΩΔΙΚΟΣ	είσοδος	ΠΑΡΟΧΗ	bar	€	€
	έξοδος		Lit/min		max
ΥΔ-270010	3/8	35	250		
ΥΔ-270013	1/2	60	250		
ΥΔ-270019	3/4	100	250		



ΒΑΝΕΣ ΜΑΝΤΕΜΕΝΙΕΣ ΕΞΑΟΔΕΣ ανοικτό κεντρο

ΚΩΔΙΚΟΣ	είσοδος	ΠΑΡΟΧΗ	bar	€	€
	έξοδος		Lit/min		max
ΥΔ-280010	3/8	35	250		
ΥΔ-280013	1/2	60	250		



ΒΑΝΕΣ ΑΤΣΑΛΙΝΕΣ ΕΞΑΟΔΕΣ ανοικτό κεντρο

ΚΩΔΙΚΟΣ	είσοδος	ΠΑΡΟΧΗ	bar	€	€
	έξοδος		Lit/min		max
ΥΔ-290010	3/8	40	300		
ΥΔ-290013	1/2	60	300		



ΜΑΝΟΜΕΤΡΑ ΑΠΛΑ ΜΕΤΑΛΙΚΑ



Φ63 ΚΑΤΩ ΒΟΛΤΑ 1/4			
ΚΩΔΙΚΟΣ	BAR	€	+ ΦΠΑ
MA-106002	2,5		
MA-106006	6		
MA-106012	12		
MA-106016	16		
MA-106025	25		



Φ 63 ΠΙΣΩ ΒΟΛΤΑ 1/4			
ΚΩΔΙΚΟΣ	BAR	€	+ ΦΠΑ
MA-116002	2,5		
MA-116006	6		
MA-116012	12		
MA-116016	16		
MA-116025	25		



ΜΑΝΟΜΕΤΡΑ ΑΕΡΟΜΕΤΡΩΝ			
MA-000002	ΚΑΤΩ ΒΟΛΤΑ Φ63		
MA-000003	ΠΙΣΩ ΒΟΛΤΑ Φ63		
MA-000004	ΠΙΣΩ ΒΟΛΤΑ Φ80		



Φ 50 ΠΙΣΩ ΒΟΛΤΑ 1/4			
MA-115002	2,5		
MA-115006	6		
MA-115012	12		
MA-115016	16		

Φ 40 ΠΙΣΩ ΒΟΛΤΑ 1/8			
MA-114002	2,5		
MA-114006	6		
MA-114012	12		

ΜΑΝΟΜΕΤΡΑ ΓΛΥΚΕΡΙΝΗΣ ΑΝΟΞΕΙΔΩΤΑ Φ63



Φ63 ΚΑΤΩ ΒΟΛΤΑ 1/4			
ΚΩΔΙΚΟΣ	BAR	€	+ ΦΠΑ
MA-206000	-1		
MA-206001	-1+2.5		
MA-206099	1		
MA-206002	2,5		
MA-206006	6		
MA-206010	10		
MA-206016	16		
MA-206025	25		
MA-206040	40		
MA-206060	60		
MA-206080	80		
MA-206100	100		
MA-206160	160		
MA-206250	250		
MA-206315	315		
MA-206400	400		
MA-206600	600		
MA-206111	1000		



Φ 63 ΠΙΣΩ ΒΟΛΤΑ 1/4			
ΚΩΔΙΚΟΣ	BAR	€	+ ΦΠΑ
MA-216000	-1		
MA-216001	-1+2.5		
MA-216099	1		
MA-216002	2,5		
MA-216006	6		
MA-216010	10		
MA-216016	16		
MA-216025	25		
MA-216040	40		
MA-216060	60		
MA-216080	80		
MA-216100	100		
MA-216160	160		
MA-216250	250		
MA-216315	315		
MA-216400	400		
MA-216600	600		
MA-216111	1000		



ΜΑΝΟΜΕΤΡΑ ΠΛΥΣΤΙΚΩΝ			
MA-214250	Φ40 ΠΒ.315 bar 1/8		
MA-215250	Φ50 ΠΒ315 bar 1/4		



ΦΛΑΝΤΖΑ ΣΤΗΡΙΞΗΣ			
MA-000006	D 63		



ΜΕΤΑΛΛΙΚΗ ΒΑΣΗ ΣΤΗΡΙΞΗΣ			
MA-000005	ΓΙΑ Φ40		
MA-000000	ΓΙΑ Φ50		
MA-000001	ΓΙΑ Φ63		

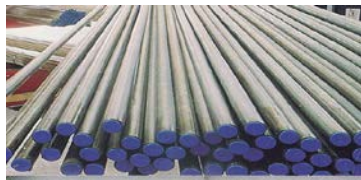

ΣΙΔΗΡΟΣΩΛΗΝΕΣ
DIN 2391
MANNESMAN

**ΣΤΗΡΙΓΜΑΤΑ
ΣΙΔΗΡΟΣΩΛΗΝΩΝ
ΑΠΛΑ**

ΚΩΔΙΚΟΣ	ΣΩΛΗΝΑ	€	+ΦΠΑ
ΣΒ-310006	6		
ΣΒ-310008	8		
ΣΒ-310010	10		
ΣΒ-310012	12		
ΣΒ-310014	14		
ΣΒ-310015	15		
ΣΒ-310016	16		
ΣΒ-310018	18		
ΣΒ-310020	20		
ΣΒ-310022	22		
ΣΒ-310025	25		
ΣΒ-310028	28		
ΣΒ-310030	30		
ΣΒ-310035	35		
ΣΒ-310038	38		
ΣΒ-310042	42		



ΚΩΔΙΚΟΣ	ΔΙΑΣΤΑΣΗ	W.Pbar	€	+ΦΠΑ
ΣΒ-300005	3\16			
ΣΒ-300006	6X0,75			
ΣΒ-300008	8X0,75			
ΣΒ-300604	6X1	509		
ΣΒ-300603	6X1,5	825		
ΣΒ-300602	6X2μπεκ	1200		
ΣΒ-300806	8X1	367		
ΣΒ-300805	8X1,5	583		
ΣΒ-300804	8X2	825		
ΣΒ-301008	10X1	287		
ΣΒ-301007	10X1,5	450		
ΣΒ-301009	10X2	963		
ΣΒ-301209	12X1,5	367		
ΣΒ-301208	12X2	508		
ΣΒ-301410	14X2	508		
ΣΒ-301512	15X1,5	287		
ΣΒ-301511	15X2	394		
ΣΒ-301612	16X2	367		
ΣΒ-301814	18X2	322		
ΣΒ-302016	20X2,5	367		
ΣΒ-302014	20X3	451		
ΣΒ-302218	22X2	259		
ΣΒ-302520	25X2,5	287		
ΣΒ-302519	25X3	351		
ΣΒ-302824	28X2	200		
ΣΒ-303024	30X3	287		
ΣΒ-303022	30X4	394		
ΣΒ-303529	35X3	243		
ΣΒ-303830	38X4	303		
ΣΒ-304238	42X3	200		

ΣΤΗΡΙΓΜΑΤΑ ΒΑΡΕΩΣ ΤΥΠΟΥ



ΣΒ-310118	18		
ΣΒ-310120	20		
ΣΒ-310125	25		
ΣΒ-310130	30		
ΣΒ-310131	30μεγ.		
ΣΒ-310135	35		
ΣΒ-310138	38		
ΣΒ-310142	42		
ΣΒ-310150	50		

**ΣΤΗΡΙΓΜΑΤΑ
ΔΙΠΛΑ**

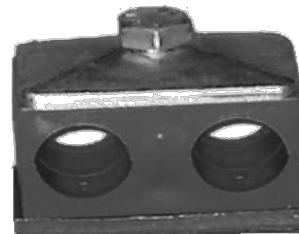

ΣΒ-310206	6		
ΣΒ-310208	8		
ΣΒ-310210	10		
ΣΒ-310212	12		
ΣΒ-310214	14		
ΣΒ-310215	15		
ΣΒ-310216	16		
ΣΒ-310218	18		
ΣΒ-310220	20		
ΣΒ-310222	22		
ΣΒ-310225	25		
ΣΒ-310228	28		
ΣΒ-310230	30		
ΣΒ-310235	35		
ΣΒ-310238	38		
ΣΒ-310242	42		

ΣΤΗΡΙΓΜΑΤΑ ΜΕ ΛΑΣΤΙΧΟ AGD W1 DIN 3016 ΜΙΚΑΛΟΡ

ΚΩΔΙΚΟΣ	ΔΙΑΣΤΑΣΗ	ΠΛΑΤΟΣ	€	+ΦΠΑ
ΣΦ-310010	4	12		
ΣΦ-310020	5	12		
ΣΦ-310031	6	12		
ΣΦ-310041	8	12		
ΣΦ-310061	10	12		
ΣΦ-310071	12	12		
ΣΦ-310091	15	15		
ΣΦ-310102	16	15		
ΣΦ-310112	18	15		



ΚΩΔΙΚΟΣ	ΔΙΑΣΤΑΣΗ	ΠΛΑΤΟΣ	€	+ΦΠΑ
ΣΦ-310123	20	15		
ΣΦ-310133	22	15		
ΣΦ-310134	23	15		
ΣΦ-310135	24	15		
ΣΦ-310153	25	15		

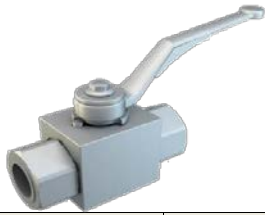

ΔΙΣΤΟΜΕΣ GE1

ΚΩΔΙΚΟΣ	ΔΙΑΣΤΑΣΗ	bar w.p	€	+ ΦΠΑ
PΣ-008020	1\4	500		
PΣ-008021	3\8	500		
PΣ-008022	1\2	500		

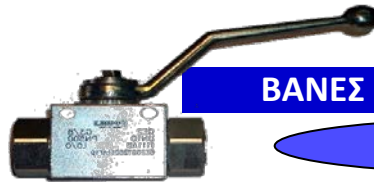

BANES ΔΙΣΤΟΜΕΣ GE2 B.S.P.

ΤΡΥΠΕΣ ΣΤΗΡΙΞΗΣ

ΚΩΔΙΚΟΣ	ΔΙΑΣΤΑΣΗ	bar w.p	€		
PΣ-008001	1\4	500			
PΣ-008002	3\8	500			
PΣ-008003	1\2	500			
PΣ-008004	3\4	420			
PΣ-008005	1"	420			
PΣ-008006	1" 1\4 DN25	350			

ΔΙΣΤΟΜΕΣ GE2 ΜΕΤΡΙΚΕΣ

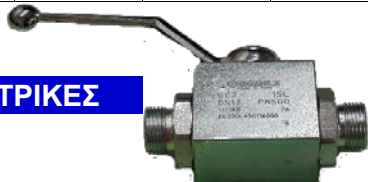

ΚΩΔΙΚΟΣ	ΔΙΑΣΤΑΣΗ	bar w.p	€	+ ΦΠΑ
PΣ-008030	12L	500		
PΣ-008031	12S	500		
PΣ-008033	15L	500		
PΣ-008041	18L	500		
PΣ-008040	22L	400		
PΣ-008034	16S	500		
PΣ-008035	20S	500		
PΣ-008036	25S	400		
PΣ-008037	30S	350		
PΣ-008038	38S	350		

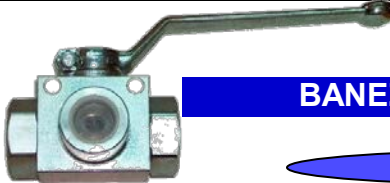

BANES ΤΡΙΣΤΟΜΕΣ GE3

ΤΡΥΠΕΣ ΣΤΗΡΙΞΗΣ

ΚΩΔΙΚΟΣ	ΔΙΑΣΤΑΣΗ	bar w.p	€		
PΣ-008101	1\4	500			
PΣ-008102	3\8	500			
PΣ-008103	1\2	500			
PΣ-008104	3\4	420			
PΣ-008125	1"	420			
PΣ-008126	1" 1\4 DN25	350			

Οι βάνες B.S.P έχουν τρύπες για την στήριξη.



ΔΙΣΤΟΜΕΣ GB1 FULL



ΚΩΔΙΚΟΣ	ΔΙΑΣΤΑΣΗ	bar w.p	€	+ ΦΠΑ
PΣ-008009	1\4 DN 32	420		
PΣ-008007	1\2 DN 40	420		
PΣ-008008	2" DN 50	420		

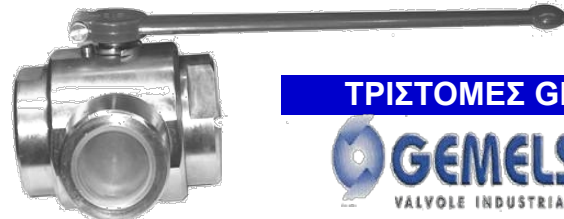
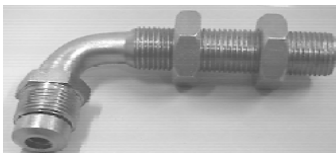

ΤΡΙΣΤΟΜΕΣ GB3 FULL



ΚΩΔΙΚΟΣ	ΔΙΑΣΤΑΣΗ	bar w.p	€		
PΣ-008132	1"1\4	350			
PΣ-008138	1"1\2	350			



ΑΝΤΑΛΑΚΤΙΚΑ ΧΕΡΟΥΛΙΑ

PΣ-008098	KIT GE 1/4-1/2				
PΣ-008099	GE 3/4 -1\4				
PΣ-008100	GB μεγάλο				



ΜΑΣΤΟΙ ΚΟΝΤΡΑ

ΓΩΝΙΕΣ ΑΝΑΤΡΟΠΗΣ Α-Α

ΚΩΔΙΚΟΣ	ΑΡΣ. ΤΡΕΛΟ	ΚΟΝΤΡΑ	€	+ ΦΠΑ
PΣ-111010	3\8	3\8		
PΣ-111313	1\2	1\2		
PΣ-111314	1\2	1\2 μακρύ		
PΣ-111322	1\2	22χ1,5		
PΣ-111323	1\2	22χ1,5 μακρύ		
PΣ-111919	3\4	3\4		

ΚΩΔΙΚΟΣ	ΒΑΣΗ	ΚΟΝΤΡΑ	€		
PΣ-151012	3\8	18X1,5			
PΣ-151312	1\2	18X1,5			
PΣ-151315	1\2	22X1,5			
PΣ-151319	1\2	3\4X16			
PΣ-151322	1\2	7\8X14			
PΣ-151320	1\2	13\16 ORFS			
PΣ-151325	1\2	1" ORFS			
PΣ-151925	3\4	1" ORFS			

FASTER[®]

Quick-release couplings

Serie
Series **MULTIFASTER**
4SFPV
VF



Serie
Series **NV**
PV
CPV



Serie
Series **3CFPV**
VF



FASTER[®]

The future from our experience.



ISO 9001 - Cert. n° 0037



Worldwide Faster



Ταχυσύνδεσμοι κορυφαίας ποιότητας που τοποθετούν σχεδόν όλοι οι κατασκευαστές παγκοσμίως.



ΣΥΝΤΕΛΕΣΤΗΣ ΑΣΦΑΛΕΙΑΣ 1:4

Η σειρά ANV είναι κατάλληλη για χρήση σε βιομηχανικές και αγροτικές εφαρμογές. Σύνδεση και αποσύνδεση με το δαχτυλίδι. Σύσφιξη από 10-16 μπίλιες (ανάλογα με το μέγεθος). Στην αποσύνδεση παρέχεται η τέλεια στεγανοποίηση ακόμη και σε χαμηλή πίεση. Κατασκευασμένοι σύμφωνα με: ISO

ΤΑΧΥΣΥΝΔΕΣΜΟΙ ΑΡΣΕΝΙΚΟΙ (κούμπωμα) ANV

ΚΩΔΙΚΟΣ	ΤΥΠΟΣ	W.P.bar	Lt/min	€	+ΦΠΑ
PΣ-008014	1\4	500	8		
PΣ-008010	3\8	300	30		
PΣ-008011	1\2	300	75		
PΣ-008011A	1\2AGRI	250	75		
PΣ-008012	3\4	300	180		
PΣ-008013	1"	250	270		
PΣ-008015	1" 1\4	250	330		
PΣ-008016	1" 1\2	200	450		
PΣ-008017	7\8	300	65		

ΤΑΧΥΣΥΝΔΕΣΜΟΙ ΑΡΣΕΝΙΚΟΙ (κούμπωμα) NV

PΣ-008018	3\4	300	150		
PΣ-008019	1"	250	220		

ΤΑΧΥΣΥΝΔΕΣΜΟΙ ΘΗΛΥΚΟΙ (σώμα) ANV

PΣ-008209	1\4	500	8		
PΣ-008210	3\8	300	30		
PΣ-008211	1\2	300	75		
PΣ-008212	3\4	300	180		
PΣ-008213	1"	250	270		
PΣ-008214	1" 1\4	250	330		
PΣ-008215	1" 1\2	200	450		
PΣ-008216	7\8	300	65		

ΤΑΧΥΣΥΝΔΕΣΜΟΙ ΘΗΛΥΚΟΙ (σώμα) NV

PΣ-008217	3\4	300	150		
PΣ-008218	1"	250	220		

ΤΑΠΕΣ ΠΡΟΣΤΑΣΙΑΣ ΤΑΧΥΣΥΝΔΕΣΜΩΝ ΣΕΙΡΑΣ ANV



ΤΑΠΕΣ ΓΙΑ ΑΡΣΕΝΙΚΑ ΚΟΥΜΠΩΜΑΤΑ ANV

PΣ-008416	1\4			
PΣ-008417	3\8			
PΣ-008418	1\2			
PΣ-008420	3\4			
PΣ-008421	1"			

ΤΑΠΕΣ ΓΙΑ ΘΗΛΥΚΑ ΚΟΥΜΠΩΜΑΤΑ ANV

PΣ-008422	1\4			
PΣ-008423	3\8			
PΣ-008419	1\2			
PΣ-008424	3\4			
PΣ-008425	1"			

ΤΑΧΥΣΥΝΔΕΣΜΟΙ ΑΓΡΟΤΙΚΟΙ (trailer) ΣΕΙΡΑ PV



ΚΩΔΙΚΟΣ	ΤΥΠΟΣ	W.P.bar	Lt/min	€	+ΦΠΑ
PΣ-008221	1½ ΘΗΛΥΚΟ	260	75		
PΣ-008223	ΑΡΣ. 22x1,5 ΜΕ ΟΙΡ	260	75		
PΣ-008225	ΑΡΣ. 18X1.5 ΚΟΝΤΡΑ	260	75		
PΣ-008226	ΑΡΣ. 22X1.5 ΚΟΝΤΡΑ	260	75		
PΣ-008227	¾X16 ΘΗΛΥΚΟ	250	75		

Η τιμή είναι μόνο για το θηλυκό σώμα

Κούμπωμα το αρσενικό 1/2 (PΣ-008011) απλού ταχυσυνδέσμου

Σύνδεση πιέζοντας το κούμπωμα. Αποσύνδεση τραβώντας το κούμπωμα. Κατασκευασμένοι σύμφωνα με ISO 7241-1
Λειτουργία breakaway



ΤΑΧΥΣΥΝΔΕΣΜΟΙ ΑΓΡΟΤΙΚΟΙ (trailer) ΣΕΙΡΑ 3CFHF high flow



ΚΩΔΙΚΟΣ	ΤΥΠΟΣ	W.P.bar	Lt/min	€	+ΦΠΑ
PΣ-008220	¾αρσ.	250	70		
PΣ-008222	1½	250	70		
PΣ-008229	A 18x1,5	250	70		
PΣ-008224	A 22x1,5	250	70		

Η τιμή είναι μόνο για το θηλυκό σώμα

Κούμπωμα το αρσενικό 1/2 (PΣ-008011) απλού ταχυσυνδέσμου

Νέα σειρά με κούμπωμα 3/8

PΣ-008228	A 14X1,5	250	30		
ΚΑΠΑΚΙΑ ΑΥΤΟΜΑΤΑ ΓΙΑ TRAILOR ΤΑΧ/ΣΜΟΥΣ					
ΚΩΔΙΚΟΣ	ΔΙΑΣΤΑΣΗ	ΤΥΠΟΣ	€	+ΦΠΑ	
PΣ-008430	1½	TA 12			

Σύνδεση πιέζοντας το κούμπωμα. Αποσύνδεση τραβώντας το κούμπωμα (25N) Κατασκευασμένοι σύμφωνα με ISO 7241-A
Λειτουργία breakaway



ΧΕΙΡΟΛΑΒΗ FAST GRIP 1/2

PΣ-008431	FAST GRIP 1/2				
-----------	---------------	--	--	--	--

ΑΥΤΟΛΙΠΑΝΣΗΣ ΦΟΡΤΗΓΩΝ



ΚΩΔΙΚΟΣ	ΤΥΠΟΣ	ΣΠΕΙΡΩΜΑ	W.P.bar	Lt/min	€	+ΦΠΑ
PΣ-008340	ΣΩΜΑ	1¼	350	15		
PΣ-008339	ΚΟΥΜΠΩΜΑ	1¼	350	15		

ΤΑΧΥΣΥΝΔΕΣΜΟΣ ΔΙΑΓΝΩΣΗΣ DF



ΚΩΔΙΚΟΣ	ΠΕΡΙΓΡΑΦΗ	W.P.bar	Lt/min	€	+ΦΠΑ
PΣ-008337	A κούμπωμα θηλ. 1/4	470	2		
PΣ-008338	B σώμα θηλ. 1/4	470	2		



ΤΑΧΥΣΥΝΔΕΣΜΟΣ ΦΡΕΝΩΝ VF

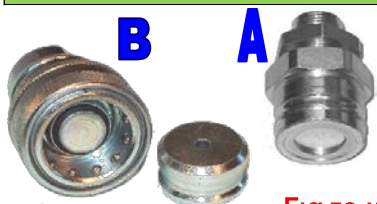

ΚΩΔΙΚΟΣ	ΠΕΡΙΓΡΑΦΗ	W.P.bar	Lt/min	€	+ΦΠΑ
PΣ-008441	A" 18X1,5 αρσ.& κόντρα	220	40		
PΣ-008440	B" θηλ. 18x1,5 & τάπα	220	40		
PΣ-008444	ΤΑΠΑ για αρσ. A"				
PΣ-008445	ΤΑΠΑ για θηλ. B" μεταλική				

Για το υδραυλικό σύστημα φρένων αγροτικών μηχανημάτων.

ΤΑΧΥΣΥΝΔΕΣΜΟΙ ΙΣΙΑ ΕΔΡΑ ΣΕΙΡΑ FFH



Κατασκευασμένοι σύμφωνα με :

ISO-DIS 16028



ΤΑΧΥΣΥΝΔΕΣΜΟΙ FFH ΑΡΣΕΝΙΚΟΙ (κούμπωμα)

ΚΩΔΙΚΟΣ	ΤΥΠΟΣ	W.P.bar	Lt/min	Dmm	€	+ΦΠΑ
PΣ-008308	1\4	350	25	16,10		
PΣ-008310	3\8	350	50	19,70		
PΣ-008311	1\2	350	50	19,70		
PΣ-008312	3\4	350	110	24,50		
PΣ-008315	3\4(27)	350	125	27,00		
PΣ-008313	1"	350	160	29,90		
PΣ-008314	1"1\4	350	230	36,00		
PΣ-008380	9\16	350	50	16,10		
PΣ-008317	3\4X16	350	110	24,50		
PΣ-008348	7\8	350	110	24,50		
PΣ-008349	1"1\16	350	110	24,50		
PΣ-008316	1"5\16	350	160	29,90		

3FFH σύνδεση-αποσύνδεση ακόμα με μεγάλη πίεση

PΣ-008345	3\4	250	78	24,5		
PΣ-008347	3\4FULL	250	135	29,9		
PΣ-008346	1"	250	135	29,9		

ΤΑΧΥΣΥΝΔΕΣΜΟΙ FFH ΘΗΛΥΚΟΙ (σώμα)

ΚΩΔΙΚΟΣ	ΤΥΠΟΣ	W.P.bar	Lt/min	Dmm	€	+ΦΠΑ
PΣ-008309	1\4	350	25	27		
PΣ-008321	3\8	350	50	30		
PΣ-008322	1\2	350	50	30		
PΣ-008323	3\4	350	110	38		
PΣ-008329	3\4(27)	350	125	42		
PΣ-008324	1"	350	160	48		
PΣ-008325	1"1\4	350	230	55		
PΣ-008381	9\16	350	50	27		
PΣ-008331	3\4X16	350	110	38		
PΣ-008350	7\8	350	110	38		
PΣ-008351	1"1\16	350	110	38		
PΣ-008330	1"5\16	350	160	48		

ΤΑΧΥΣΥΝΔΕΣΜΟΙ FFH ΑΡΣΕΝΙΚΟΙ FULL (κούμπωμα)

ΚΩΔΙΚΟΣ	ΤΥΠΟΣ	W.P.bar	Lt/min	Dmm	€	+ΦΠΑ
PΣ-008318	1\2	350	110	24,5		
PΣ-008319	3\4	350	160	29,95		
PΣ-008320	1"	350	230	36		
PΣ-008332	1"1\16	350	160	29,95		

ΤΑΧΥΣΥΝΔΕΣΜΟΙ FFH ΘΗΛΥΚΟΙ FULL (σώμα)

ΚΩΔΙΚΟΣ	ΤΥΠΟΣ	W.P.bar	Lt/min	Dmm	€	+ΦΠΑ
PΣ-008326	1\2	350	110	38		
PΣ-008327	3\4	350	160	48		
PΣ-008328	1"	350	230	55		
PΣ-008333	1"1\16	350	160	48		

ΤΑΠΕΣ ΓΙΑ ΑΡΣΕΝΙΚΑ FFH (κούμπωμα)



PΣ-008382	1\4 & 9\16			16,10		
PΣ-008352	3\8 & 1\2			19,7		
PΣ-008353	1\2 FULL & 3\4			24,5		
PΣ-008354	3\4 FULL & 1"			29,9		
PΣ-008355	1" FULL & 1"1\4			36		

ΤΑΠΕΣ ΓΙΑ ΘΗΛΥΚΑ FFH (σώμα)



PΣ-008383	1\4 & 9\16			27		
PΣ-008356	3\8 & 1\2			30		
PΣ-008357	1\2 FULL & 3\4			38		
PΣ-008358	3\4 FULL & 1"			48		
PΣ-008359	1" FULL & 1"1\4			55		

ΤΑΧΥΣΥΝΔΕΣΜΟΙ ΒΙΔΩΤΟΙ ΣΕΙΡΑ CVV (FULL ΠΑΡΟΧΗΣ)

Α ΒΙΔΩΤΟ	ΤΥΠΟΣ	bar	Lt	€	+ΦΠΑ
PΣ-008151	1\4	370	13		
PΣ-008152	3\8	300	25		
PΣ-008153	1\2	300	65		
PΣ-008154	3\4	270	100		
PΣ-008155	1"	270	205		
PΣ-008156	1" 1\2	270	450		
Β ΣΩΜΑ	ΤΥΠΟΣ	bar	Lt	€	+ΦΠΑ
PΣ-008251	1\4	370	13		
PΣ-008252	3\8	300	25		
PΣ-008253	1\2	300	65		
PΣ-008254	3\4	270	100		
PΣ-008255	1"	270	205		
PΣ-008256	1" 1\2	270	450		

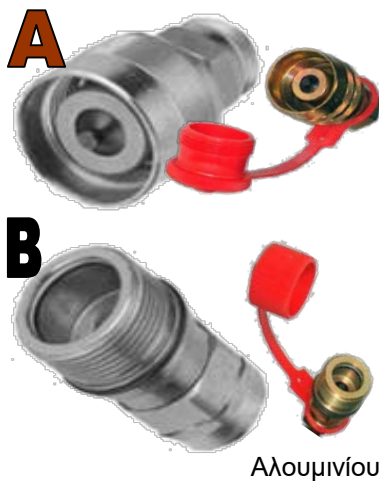

ΤΑΠΕΣ ΓΙΑ ΒΙΔΩΤΟ "Α"			
ΚΩΔΙΚΟΣ	ΤΥΠΟΣ	€	+ΦΠΑ
PΣ-008370	1\2		
PΣ-008371	3\4		
PΣ-008372	1"		
PΣ-008373	1" 1\2		

Αλουμινίου			
ΚΩΔΙΚΟΣ	ΤΥΠΟΣ	€	+ΦΠΑ
PΣ-008372A	1"		
ΤΑΠΕΣ ΓΙΑ ΣΩΜΑ "Β"			
PΣ-008375	1\2		
PΣ-008376	3\4		
PΣ-008377	1"		
PΣ-008378	1" 1\2		
PΣ-008377A	1"		

ΤΑΧΥΣΥΝΔΕΣΜΟΙ ΒΙΔΩΤΟΙ ΣΕΙΡΑ CVE CAMION (ΑΝΑΤΡΟΠΗΣ)

Α) ΠΕΤΑΛΟΥΔΑ ΤΑΧ/ΣΜΟΣ ΑΝΑΤΡΟΠΗΣ					
Α ΒΙΔΩΤΟ	ΤΥΠΟΣ	bar	Lt/min	€	+ΦΠΑ
PΣ-008391	3\4	360	120		
PΣ-008393	1"	300	160		



ΤΑΠΕΣ ΓΙΑ ΒΙΔΩΤΟ "Α"			
ΚΩΔΙΚΟΣ	ΤΥΠΟΣ	€	+ΦΠΑ
PΣ-008394	3\4		
PΣ-008395	1"		

Β) ΣΩΜΑ ΜΕ ΚΟΝΤΡΑ ΣΤΗΡΙΞΗΣ 1" 1/4					
Β ΣΩΜΑ	ΤΥΠΟΣ	bar	Lt/min	€	+ΦΠΑ
PΣ-008390	3\4	360	120		
PΣ-008392	1"	300	160		

ΤΑΠΕΣ ΓΙΑ ΣΩΜΑ "Β"			
ΚΩΔΙΚΟΣ	ΤΥΠΟΣ	€	+ΦΠΑ
PΣ-008396	3\4		
PΣ-008397	1"		

Κατασκευασμένοι σύμφωνα με : **DIN 3852-2-X**

ΒΙΔΩΤΟΙ ΒΑΡΕΩΣ ΤΥΠΟΥ ΣΕΙΡΑ PVVM 1000 bar

Α ΒΙΔΩΤΟ	ΤΥΠΟΣ	bar	Lt/min	€	+ΦΠΑ
PΣ-008341	1\4	1050	15		
PΣ-008342	3\8	1000	20		



ΤΑΠΕΣ ΑΛΟΥΜΙΝΙΟΥ ΓΙΑ "Α"			
ΚΩΔΙΚΟΣ	ΤΥΠΟΣ	€	+ΦΠΑ
PΣ-008360	1\4		
PΣ-008361	3\8		

Β ΚΟΥΜΠΩΜΑ	ΤΥΠΟΣ	bar	Lt/min	€	+ΦΠΑ
PΣ-008343	1\4	1050	15		
PΣ-008344	3\8	1000	20		

ΤΑΠΕΣ ΑΛΟΥΜΙΝΙΟΥ ΓΙΑ "Β"			
ΚΩΔΙΚΟΣ	ΤΥΠΟΣ	€	+ΦΠΑ
PΣ-008362	1\4		
PΣ-008363	3\8		

ΒΙΔΩΤΟΙ ΒΑΡΕΩΣ ΤΥΠΟΥ ΣΕΙΡΑ VVS (very high pressure)

ΚΩΔΙΚΟΣ	ΤΥΠΟΣ	bar	Lt/min	€	+ΦΠΑ
PΣ-008334	3\4	700	45		
PΣ-008335	1"	530	90		

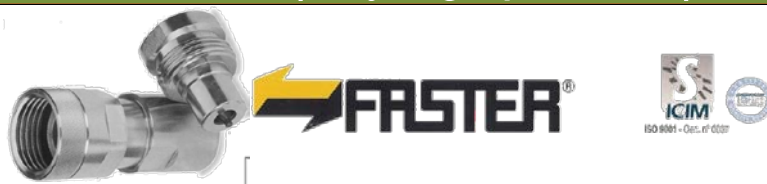

ΣΕΙΡΑ 4BD για BOBCAT GEHL CATERPILAR

ΚΩΔΙΚΟΣ	ΤΥΠΟΣ	ΣΠΕΙΡΩΜΑ	€	+ΦΠΑ
PΣ-008470	3/4 ΘΗΛ. ΚΙΤ4FI12F	46x1,5		
PΣ-008471	3/4 ΘΗΛΚΙΤ4FSI12F	46x1,5βαρέως		
PΣ-008475	3/4 ΑΡΣ.ΚΙΤ4FI 12M	46x1,5		
PΣ-008472	3/4ΘΗΛΚΙΤ 4FSH08F	48x1,5βαρέως		
PΣ-008473	3/4 ΘΗΛΚΙΤ 4FH08F	48x1,5		
PΣ-008476	3/4 ΑΡΣ.ΚΙΤ4FH08M	48x1,5		
PΣ-008477	1/2 ΘΗΛΚΙΤ4BD06	24X1,5		
PΣ-008478	1/2 ΑΡΣ ΚΙΤ4BD06M	24X1,5		



ΣΥΣΤΗΜΑΤΑ MULTI FASTER



ΚΩΔΙΚΟΣ	ΤΥΠΟΣ		BAR/LIT	ΓΡΑΜΜΕΣ	€	+ΦΠΑ
PΣ-008480	2P506-4-12GMC	κούμπωμα	250bar-40L	4 x1/2		
PΣ-008481	2P506-4-12GFC	βάση χερούλι	250bar-40L	4 x1/2		
PΣ-008482	2P508-4-12GMC	κούμπωμα	250bar-70L	4 x1/2		
PΣ-008483	2P508-4-12GFC	βάση χερούλι	250bar-70L	4 x1/2		
PΣ-008486	2P606-6-12G MC	κούμπωμα	250bar-40L	6 x1/2		
PΣ-008487	2P606-6-12G FC	βάση χερούλι	250bar-40L	6 x1/2		
PΣ-008484	2P608-6-12GMC	κούμπωμα	250bar-70L	6 x1/2		
PΣ-008485	2P608-6-12GFC	βάση χερούλι	250bar-70L	6 x1/2		

Τιμές ισχύουν όταν υπάρχει διαθεσιμότητα.

ΣΕΙΡΑ UHP 100 1000bar (ULTRA high pressure)



ΚΩΔΙΚΟΣ	ΠΕΡΙΓΡΑΦΗ	BAR Lt/min	€	+ΦΠΑ
PΣ-008366	ΚΟΥΜΠΩΜΑ 1/4	1000 / 4		
PΣ-008367	ΣΩΜΑ 1/4	1000 / 4		

ΣΕΙΡΑ UHP 150 1500bar (extra high pressure)



ΚΩΔΙΚΟΣ	ΠΕΡΙΓΡΑΦΗ	BAR Lt/min	€	+ΦΠΑ
PΣ-008364	ΚΟΥΜΠΩΜΑ 1/4	1500 / 4		
PΣ-008365	ΣΩΜΑ 1/4	1500 / 4		

ΝΕΑ ΣΕΙΡΑ FLV ΙΣΙΑ ΕΔΡΑ ΒΙΔΩΤΟΙ 420bar

ΚΟΥΜΠΩΜΑ



FASTER

The future from our experience.

ΚΩΔΙΚΟΣ	ΤΥΠΟΣ	ΠΑΡΟΧΗ ΛΙΤΡΑ	ΣΠΕΙΡΩΜΑ ΣΥΝΔΕΣΗΣ	BAR	€	+ΦΠΑ
PΣ-008901	12L Αρσενικο	3/8-42L	32X3	420		
PΣ-008902	12S Αρσενικο	3/8-42L	32X3	420		
PΣ-008903	14S Αρσενικο	3/8-42L	32X3	420		
PΣ-008904	15L Αρσενικο	3/8-42L	32X3	420		
PΣ-008905	16S Αρσενικο	3/8-42L	32X3	420		
PΣ-008906	15L Αρσενικο	1/2-75L	36X3	420		
PΣ-008907	16S Αρσενικο	1/2-75L	36X3	420		
PΣ-008908	20S Αρσενικο	1/2-75L	36X3	420		
PΣ-008909	20S Αρσενικο	3/4-120L	48X3	420		
PΣ-008910	20S Αρσενικο	1"-165L	54X4	420		
PΣ-008911	25S Αρσενικο	1"-165L	54X4	420		
PΣ-008912	35L Αρσενικο	1"1/4-430L	79X4	420		
PΣ-008913	38S Αρσενικο	1"1/4-430L	79X4	420		

ΒΑΣΗ



FASTER

The future from our experience.

ΚΩΔΙΚΟΣ	ΤΥΠΟΣ	ΠΑΡΟΧΗ ΛΙΤΡΑ	ΣΠΕΙΡΩΜΑ ΣΥΝΔΕΣΗΣ	BAR	€	+ΦΠΑ
PΣ-008921	12L Αρσενικο	3/8-42L	#ΤΙΜΗ!	420		
PΣ-008922	12S Αρσενικο	3/8-42L	32X3	420		
PΣ-008923	14S Αρσενικο	3/8-42L	32X3	420		
PΣ-008924	15L Αρσενικο	3/8-42L	32X3	420		
PΣ-008925	16S Αρσενικο	3/8-42L	32X3	420		
PΣ-008926	15L Αρσενικο	1/2-75L	36X3	420		
PΣ-008927	16S Αρσενικο	1/2-75L	36X3	420		
PΣ-008928	20S Αρσενικο	1/2-75L	36X3	420		
PΣ-008929	20S Αρσενικο	3/4-120L	48X3	420		
PΣ-008930	20S Αρσενικο	1"-165L	54X4	420		
PΣ-008931	25S Αρσενικο	1"-165L	54X4	420		
PΣ-008932	35L Αρσενικο	1"1/4-430L	79X4	420		
PΣ-008933	38S Αρσενικο	1"1/4-430L	79X4	420		

CAST[®]

LINEA PRODOTTI

**SERIE
DIN B3-B4**

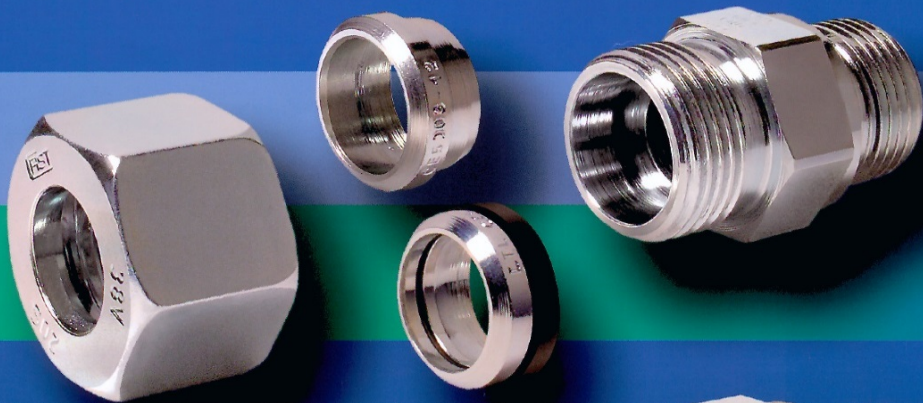

**SERIE
SAE-JIC**

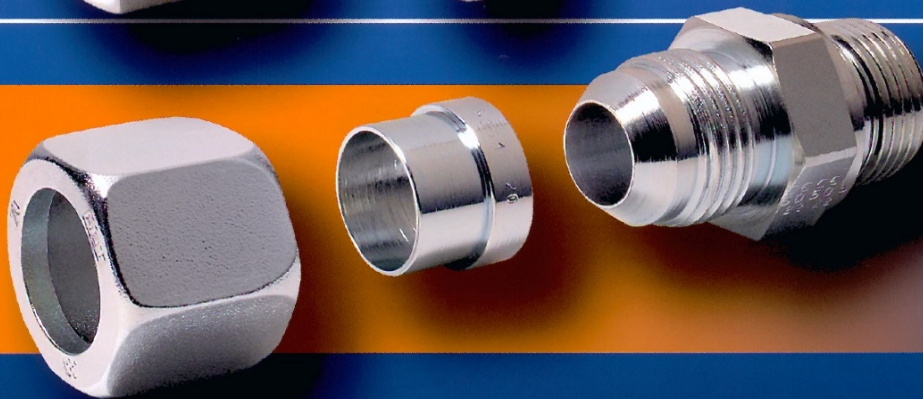

**SERIE
SAE-ORFS**



**SERIE
BSI**

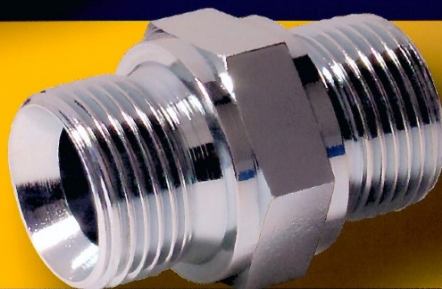

AST[®]

QUALITA' CERTIFICATA



FOR A CONSTANT IMPROVEMENT

ΠΑΞΙΜΑΔΙΑ



ΚΩΔΙΚΟΣ	ΠΕΡΙΓΡΑΦΗ	ΣΠΕΙΡΩΜΑ	€	+ΦΠΑ
PΣ-000201	4LL	8X1		
PΣ-000202	6LL	10X1		
PΣ-000203	8LL	12X1		
PΣ-000204	6L	12X1.5		
PΣ-000205	8L	14X1,5		
PΣ-000206	10L	16X1,5		
PΣ-000207	12L	18X1,5		
PΣ-000208	15L	22X1,5		
PΣ-000209	18L	26X1,5		
PΣ-000210	22L	30X2		
PΣ-000211	28L	36X2		
PΣ-000212	35L	45X2		
PΣ-000213	42L	52X2		
PΣ-000214	6S	14X1,5		
PΣ-000215	8S	16X1,5		
PΣ-000216	10S	18X1,5		
PΣ-000217	12S	20X1,5		
PΣ-000218	14S	22X1,5		
PΣ-000219	16S	24X1,5		
PΣ-000220	20S	30X2		
PΣ-000221	25S	36X2		
PΣ-000222	30S	42X2		
PΣ-000223	38S	52X2		

ΜΠΙΜΠΙΚΙΑ

ΚΩΔΙΚΟΣ	ΠΕΡΙΓΡΑΦΗ	€	+ΦΠΑ
PΣ-000101	4LL		
PΣ-000102	6LL		
PΣ-000103	8LL		
PΣ-000104	6L		
PΣ-000105	8L		
PΣ-000106	10L		
PΣ-000107	12L		
PΣ-000108	15L		
PΣ-000109	18L		
PΣ-000110	22L		
PΣ-000111	28L		
PΣ-000112	35L		
PΣ-000113	42L		
PΣ-000118	14S		
PΣ-000119	16S		
PΣ-000120	20S		
PΣ-000121	25S		
PΣ-000122	30S		
PΣ-000123	38S		

ΜΠΙΜΠΙΚΙΑ 6 ΕΠΑΦΩΝ ΤΥΠΟΣ Β4

ΚΩΔΙΚΟΣ	ΠΕΡΙΓΡΑΦΗ	€	+ΦΠΑ
PΣ-100104	6L		
PΣ-100105	8L		
PΣ-100106	10L		
PΣ-100107	12L		
PΣ-100108	15L		
PΣ-100109	18L		
PΣ-100110	22L		
PΣ-100111	28L		
PΣ-100112	35L		
PΣ-100113	42L		



ΚΩΔΙΚΟΣ	ΠΕΡΙΓΡΑΦΗ	€	+ΦΠΑ
PΣ-100114	6S		
PΣ-100115	8S		
PΣ-100116	10S		
PΣ-100117	12S		
PΣ-100118	14S		
PΣ-100119	16S		
PΣ-100120	20S		
PΣ-100121	25S		
PΣ-100122	30S		
PΣ-100123	38S		



ΜΠΙΜΠΙΚΙΑ 6 ΕΠΑΦΩΝ ΤΥΠΟΣ Β4

Το μπιμπίκι Β4 συνδυάζει εκτός από τις στεγανωτικές επαφές σύσφιξης του σιδηροσωλήνα, άριστη στεγανοποίηση με Ο/Ρ στο πίσω σημείο και μια τσιμούχα ανάμεσα στο μπιμπίκι και στον κώνο του μαστού. Έτσι όταν σφίγγουμε το παξιμάδι η τσιμούχα συμπιέζεται με αποτέλεσμα να επιτυγχάνουμε άριστη στεγανότητα και απόσβεση κραδασμών.

ΣΥΝΙΣΤΑΤΑΙ ΙΔΙΑΙΤΕΡΩΣ ΣΤΑ ΧΩΜΑΤΟΥΡΓΙΚΑ ΜΗΧΑΝΗΜΑΤΑ ΣΦΥΡΙΑ - ΤΣΑΠΕΣ - ΦΟΡΤΩΤΕΣ.



ISO 9001



DET NORSKE VERITAS

TYPE APPROVAL CERTIFICATE



ΜΑΣΤΟΙ ΒΑΣΗ B.S.P με 60°κώνο βάσης

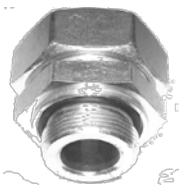

Για παραγγελία των
ρακόρ χωρίς παξιμάδια &
μπιμπίκια ο κωδικός γίνεται:
π.χ ΡΣ-Σ00304
Μαστός Σκέτος 6L-1/8

ΚΩΔΙΚΟΣ	ΣΙΔ/ΝΑ	ΒΑΣΗ	ΣΚΕΤΟ	ΚΟΜΠΛΕ	+ΦΠΑ	ΚΩΔΙΚΟΣ	ΣΙΔ/ΝΑ	ΒΑΣΗ	ΣΚΕΤΟ	ΚΟΜΠΛΕ	+ΦΠΑ
ΡΣ-000502	6LL	1\8	O/R			ΡΣ-000314	6S	1\4			
ΡΣ-000304		1\8				ΡΣ-000315		1\4			
ΡΣ-000324		1\4				ΡΣ-000541	8S	3\8	O/R		
ΡΣ-000524	6L	1\4	O/R			ΡΣ-000542		1\4	O/R		
ΡΣ-000553		3\8	O/R			ΡΣ-000316	10S	3\8			
ΡΣ-000327		1\2	O/R			ΡΣ-000543		1\2	O/R		
ΡΣ-000525		1\8	O/R			ΡΣ-000544		1\4	O/R		
ΡΣ-000505		1\4	O/R			ΡΣ-000317	12S	3\8			
ΡΣ-000305	8L	1\4				ΡΣ-000535		1\2	O/R		
ΡΣ-000526		3\8	O/R			ΡΣ-000536	14S	3\8	O/R		
ΡΣ-000527		1\2	O/R			ΡΣ-000318		1\2			
ΡΣ-000328		1\2				ΡΣ-000537		3\8	O/R		
ΡΣ-000528		1\8	O/R			ΡΣ-000319	16S	1\2			
ΡΣ-000506		1\4	O/R			ΡΣ-000545		3\4	O/R		
ΡΣ-000306		1\4				ΡΣ-000338		1\2			
ΡΣ-000329	10L	3\8				ΡΣ-000538		1\2	O/R		
ΡΣ-000529		3\8	O/R			ΡΣ-000320	20S	3\4			
ΡΣ-000530		1\2	O/R			ΡΣ-000520		3\4	O/R		
ΡΣ-000330		1\2				ΡΣ-000546		1"	O/R		
ΡΣ-000331		1\4				ΡΣ-000539	25S	3\4	O/R		
ΡΣ-000531		1\4	O/R			ΡΣ-000321		1"			
ΡΣ-000507	12L	3\8	O/R			ΡΣ-000540	30S	1"	O/R		
ΡΣ-000307		3\8				ΡΣ-000322		1"1\4			
ΡΣ-000332		1\2				ΡΣ-000354		1"			
ΡΣ-000532		1\2	O/R			ΡΣ-000547	38S	1"1\4	O/R		
ΡΣ-000333		3\8				ΡΣ-000323		1"1\2			
ΡΣ-000533		3\8	O/R								
ΡΣ-000308	15L	1\2									
ΡΣ-000508		1\2	O/R								
ΡΣ-000348		3\4									
ΡΣ-000548		3\4	O/R								
ΡΣ-000309		1\2									
ΡΣ-000509	18L	1\2	O/R								
ΡΣ-000334		3\4									
ΡΣ-000534		3\4	O/R								
ΡΣ-000549		1\2	O/R								
ΡΣ-000310	22L	3\4									
ΡΣ-000550		1"	O/R								
ΡΣ-000551		3\4	O/R								
ΡΣ-000311	28L	1"									
ΡΣ-000552		1"	O/R								
ΡΣ-000312	35L	1"1\4									
ΡΣ-000554		1"1\4	O/R								
ΡΣ-000313	42L	1"1\2									

Η σειρά ΡΣ-0005..έχει στην βάση του μαστού ειδική έδρα με λαστιχάκι O/R για πλήρη στεγανοποίηση





**ΜΑΣΤΟΙ
ΒΑΣΗ
ΜΕΤΡΙΚΟ**

**ΜΑΣΤΟΙ
ΒΑΣΗ
N.P.T.**

ΚΩΔΙΚΟΣ	ΣΙΔ/ΝΑ	ΒΑΣΗ	ΣΚΕΤΟ	ΚΟΜΠΛΕ	+ΦΠΑ
PΣ-001801	4LL	1/8			
PΣ-001802	6LL	1/8			
PΣ-001803	8LL	1/8			
PΣ-001804	6L	1/8			
PΣ-001824		1/4			
PΣ-001825	8L	1/8			
PΣ-001805		1/4			
PΣ-001826		3/8			
PΣ-001827		1/2			
PΣ-001828	10L	1/8			
PΣ-001806		1/4			
PΣ-001829		3/8			
PΣ-001830		1/2			
PΣ-001831	12L	1/4			
PΣ-001807		3/8			
PΣ-001832		1/2			
PΣ-001833	15L	3/8			
PΣ-001808		1/2			
PΣ-001809	18L	1/2			
PΣ-001834		3/4			
PΣ-001810	22L	3/4			
PΣ-001811	28L	1"			
PΣ-001812	35L	1 1/4			
PΣ-001813	42L	1 1/2			
PΣ-001814	6S	1/4			
PΣ-001815	8S	1/4			
PΣ-001816	10S	3/8			
PΣ-001817	12S	3/8			
PΣ-001835		1/2			
PΣ-001836	14S	3/8			
PΣ-001818		1/2			
PΣ-001837	16S	3/8			
PΣ-001819		1/2			
PΣ-001838	20S	1/2			
PΣ-001820		3/4			
PΣ-001839	25S	3/4			
PΣ-001821		1"			
PΣ-001840	30S	1"			
PΣ-001822		1 1/4			
PΣ-001823	38S	1 1/2			

ΚΩΔΙΚΟΣ	ΣΙΔ/ΝΑ	ΒΑΣΗ	ΣΚΕΤΟ	ΚΟΜΠΛΕ	+ΦΠΑ
PΣ-000601	4LL	8X1			
PΣ-000602	6LL	10X1			
PΣ-000624	6LL	8X1			
PΣ-000603	8LL	10X1			
PΣ-000404	6L	10X1			
PΣ-000430		12X1,5			
PΣ-000446		14X1,5			
PΣ-000440		16X1,5			
PΣ-000436		22X1,5			
PΣ-000641	8L	10X1			
PΣ-000405		12X1,5			
PΣ-000431		14X1,5			
PΣ-000441		16X1,5			
PΣ-000437		22X1,5			
PΣ-000448	10L	12X1,5			
PΣ-000406		14X1,5			
PΣ-000432		16X1,5			
PΣ-000435		18X1,5			
PΣ-000438		22X1,5			
PΣ-000444	12L	12X1,5			
PΣ-000442		14X1,5			
PΣ-000407		16X1,5			
PΣ-000433		18X1,5			
PΣ-000439		22X1,5			
PΣ-000408	15L	18X1,5			
PΣ-000434		22X1,5			
PΣ-000445		26X1,5			
PΣ-000409	18L	22X1,5			
PΣ-000634		18X1,5			
PΣ-000443		26X1,5			
PΣ-000450	22L	22X1,5			
PΣ-000410		26X1,5			
PΣ-000411	28L	33X2			
PΣ-000412	35L	42X2			
PΣ-000413	42L	48X2			
PΣ-000414	6S	12X1,5			
PΣ-000415	8S	14X1,5			
PΣ-000416	10S	16X1,5			
PΣ-000417	12S	18X1,5			
PΣ-000460		20X1,5			
PΣ-000461		22X1,5			
PΣ-000418	14S	20X1,5			
PΣ-000637	16S	18X1,5			
PΣ-000419		22X1,5			
PΣ-000619		24X1,5			
PΣ-000638	20S	22X1,5			
PΣ-000420		27X2			
PΣ-000449	25S	27X2			
PΣ-000421		33X2			
PΣ-000640	30S	33X2			
PΣ-000422		42X2			
PΣ-000423	38S	48X2			

ΚΑΒΙΛΙΑ
& O/R

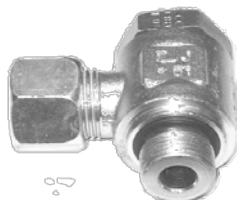

**ΓΩΝΙΕΣ ΜΕΤΑΒΛΗΤΗΣ
ΒΑΣΗ B.S.P**

Τα κομπλέ ρακόρ παξιμάδι καβίλια & λαστιχάκι O/R.

ΑΝΤΙΣΤΡΟΦΑ -ΒΑΣΗ B.S.P

ΚΩΔΙΚΟΣ	ΣΙΔ/ΝΑ	ΒΑΣΗ	ΣΚΕΤΟ	ΚΟΜΠΛΕ	+ΦΠΑ
PΣ-000904	6L	1/8			
PΣ-000924	6L	1/4			
PΣ-000905	8L	1/4			
PΣ-000906	10L	1/4			
PΣ-000929	10L	3/8			
PΣ-000931	12L	1/4			
PΣ-000907	12L	3/8			
PΣ-000932	12L	1/2			
PΣ-000933	15L	3/8			
PΣ-000908	15L	1/2			
PΣ-000909	18L	1/2			
PΣ-000910	22L	3/4			
PΣ-000911	28L	1"			
PΣ-000912	35L	1"1/4			
PΣ-000913	42L	1"1/2			
PΣ-000914	6S	1/4			
PΣ-000915	8S	1/4			
PΣ-000916	10S	3/8			
PΣ-000917	12S	3/8			
PΣ-000918	14S	1/2			
PΣ-000937	16S	3/8			
PΣ-000919	16S	1/2			
PΣ-000920	20S	3/4			
PΣ-000946	25S	3/4			
PΣ-000921	25S	1"			
PΣ-000940	30S	1"			
PΣ-000922	30S	1"1/4			
PΣ-000923	38S	1"1/2			
PΣ-001004	6L	10x1			
PΣ-001005	8L	12x1.5			
PΣ-001006	10L	14x1.5			
PΣ-001007	12L	16x1.5			
PΣ-001039	12L	22x1,5			
PΣ-001008	15L	18x1.5			
PΣ-001033	15L	22x1.5			
PΣ-001009	18L	22x1.5			
PΣ-001010	22L	26x1.5			
PΣ-001011	28L	33x2			
PΣ-001012	35L	42x2			
PΣ-001014	6S	12x1.5			
PΣ-001015	8S	14x1.5			
PΣ-001016	10S	16x1.5			
PΣ-001017	12S	18x1.5			
PΣ-001018	14S	20x1,5			
PΣ-001019	16S	22x1.5			
PΣ-001020	20S	27x2			
PΣ-001021	25S	33x2			
PΣ-001022	30S	42x2			
PΣ-001023	38S	48X2			

ΚΩΔΙΚΟΣ	ΣΙΔ/ΝΑ	ΒΑΣΗ	ΣΚΕΤΟ	ΚΟΜΠΛΕ	+ΦΠΑ
PΣ-001301	4LL	1/8			
PΣ-001302	6LL	1/8			
PΣ-001303	8LL	1/8			
PΣ-001304	6L	1/8			
PΣ-001305	8L	1/4			
PΣ-001306	10L	1/4			
PΣ-001307	12L	3/8			
PΣ-001308	15L	1/2			
PΣ-001309	18L	1/2			
PΣ-001310	22L	3/4			
PΣ-001311	28L	1"			
PΣ-001312	35L	1"1/4			
PΣ-001313	42L	1"1/2			
PΣ-001314	6S	1/4			
PΣ-001315	8S	1/4			
PΣ-001316	10S	3/8			
PΣ-001317	12S	3/8			
PΣ-001318	14S	1/2			
PΣ-001319	16S	1/2			
PΣ-001320	20S	3/4			
PΣ-001321	25S	1"			
PΣ-001322	30S	1"1/4			
PΣ-001323	38S	1"1/2			

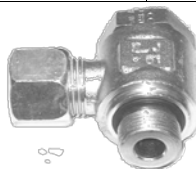

**ΓΩΝΙΕΣ ΜΕΤΑΒΛΗΤΗΣ
ΒΑΣΗ ΜΕΤΡΙΚΟ**

PΣ-001404	6L	10x1			
PΣ-001405	8L	12x1.5			
PΣ-001406	10L	14x1.5			
PΣ-001407	12L	16x1.5			
PΣ-001408	15L	18x1.5			
PΣ-001409	18L	22x1.5			
PΣ-001410	22L	26x1.5			
PΣ-001411	28L	33x2			
PΣ-001412	35L	42x2			
PΣ-001414	6S	12x1.5			
PΣ-001415	8S	14x1.5			
PΣ-001416	10S	16x1.5			
PΣ-001417	12S	18x1.5			
PΣ-001418	14S	20x1,5			
PΣ-001419	16S	22x1.5			
PΣ-001420	20S	27x2			
PΣ-001421	25S	33x2			
PΣ-001422	30S	42x2			
PΣ-001423	38S	48X2			



LAST

**ΓΩΝΙΕΣ
ΒΑΣΗ Β.Σ.Ρ.Τ.
(ΚΩΝΙΚΟ)**



**ΓΩΝΙΕΣ
ΒΑΣΗ Β.Σ.Ρ
ΚΟΝΤΡΑ**

ΚΩΔΙΚΟΣ	ΣΙΔ/ΝΑ	ΒΑΣΗ	ΣΚΕΤΟ	ΚΟΜΠΛΕ	+ΦΠΑ	ΚΩΔΙΚΟΣ	ΣΙΔ/ΝΑ	ΚΟΝΤΡΑ	ΣΚΕΤΟ	ΚΟΜΠΛΕ	+ΦΠΑ
PΣ-002001	4LL	1\8				PΣ-006104	6L	1\8			
PΣ-002002	6LL	1\8				PΣ-006105	8L	1\4			
PΣ-002003	8LL	1\8				PΣ-006106	10L	1\4			
PΣ-002004	6L	1\8				PΣ-006107	12L	3\8			
PΣ-002024		1\4				PΣ-006108	15L	1\2			
PΣ-002025	8L	1\8				PΣ-006109	18L	1\2			
PΣ-002005		1\4				PΣ-006110	22L	3\4			
PΣ-002026		3\8				PΣ-006111	28L	1"			
PΣ-002027		1\2				PΣ-006112	35L	1"1/4			
PΣ-002028	10L	1\8				PΣ-006113	42L	1"1/2			
PΣ-002006		1\4				PΣ-006114	6S	1\4			
PΣ-002029		3\8				PΣ-006115	8S	1\4			
PΣ-002030		1\2				PΣ-006116	10S	3\8			
PΣ-002031	12L	1\4				PΣ-006117	12S	3\8			
PΣ-002007		3\8				PΣ-006118	14S	1\2			
PΣ-002032		1\2				PΣ-006119	16S	1\2			
PΣ-002033	15L	3\8				PΣ-006120	20S	3\4			
PΣ-002008		1\2				PΣ-006121	25S	1"			
PΣ-002009	18L	1\2				PΣ-006122	30S	1"1/4			
PΣ-002034		3\4				PΣ-006123	38S	1"1/2			
PΣ-002010	22L	3\4									
PΣ-002011	28L	1"									
PΣ-002012	35L	1"1/4									
PΣ-002013	42L	1"1/2									
PΣ-002014	6S	1\4									
PΣ-002015	8S	1\4									
PΣ-002016	10S	3\8				PΣ-006204	6L	10x1			
PΣ-002017	12S	3\8				PΣ-006205	8L	12x1.5			
PΣ-002035		1\2				PΣ-006206	10L	14x1.5			
PΣ-002036	14S	3\8				PΣ-006207	12L	16x1.5			
PΣ-002018		1\2				PΣ-006208	15L	18x1.5			
PΣ-002037	16S	3\8				PΣ-006209	18L	22x1.5			
PΣ-002019		1\2				PΣ-006210	22L	27x2			
PΣ-002038	20S	1\2				PΣ-006211	28L	33x2			
PΣ-002020		3\4				PΣ-006212	35L	42x2			
PΣ-002039	25S	3\4				PΣ-006213	42L	48x2			
PΣ-002021		1"				PΣ-006214	6S	12x1.5			
PΣ-002040	30S	1"				PΣ-006215	8S	14x1.5			
PΣ-002022		1"1/4				PΣ-006216	10S	16x1.5			
PΣ-002023	38S	1" 1\2				PΣ-006217	12S	18x1.5			
ΓΩΝΙΕΣ ΒΑΣΗ ΜΕΤΡΙΚΕΣ (ΚΩΝΙΚΟ)											
PΣ-002204	6L	10x1				PΣ-006218	14S	20x1,5			
PΣ-002205	8L	12x1.5				PΣ-006219	16S	22x1.5			
PΣ-002206	10L	14x1.5				PΣ-006220	20S	27x2			
PΣ-002207	12L	16x1.5				PΣ-006221	25S	33x2			
PΣ-002208	15L	18x1.5				PΣ-006222	30S	42x2			
						ΑΜΒΛΕΙΕΣ ΒΑΣΗ ΜΕΤΡΙΚΕΣ ΚΟΝΤΡΑ					
						PΣ-006508	15L	18x1.5			



NEW

**ΓΩΝΙΕΣ
ΒΑΣΗ ΜΕΤΡΙΚΕΣ
ΚΟΝΤΡΑ**

**ΣΥΝΔΕΣΜΟΙ****ΣΥΝΔΕΣΜΟΙ
ΚΟΝΤΡΑ**

ΚΩΔΙΚΟΣ	ΣΙΔ/ΝΑ	ΣΚΕΤΟ	ΚΟΜΠΛΕ	+ΦΠΑ	ΚΩΔΙΚΟΣ	ΣΙΔ/ΝΑ	ΣΚΕΤΟ	ΚΟΜΠΛΕ	+ΦΠΑ
ΡΣ-003501	4LL				ΡΣ-003604	6L			
ΡΣ-003502	6LL				ΡΣ-003605	8L			
ΡΣ-003503	8LL				ΡΣ-003606	10L			
ΡΣ-003504	6L				ΡΣ-003607	12L			
ΡΣ-003505	8L				ΡΣ-003608	15L			
ΡΣ-003506	10L				ΡΣ-003609	18L			
ΡΣ-003507	12L				ΡΣ-003610	22L			
ΡΣ-003508	15L				ΡΣ-003611	28L			
ΡΣ-003509	18L				ΡΣ-003612	35L			
ΡΣ-003510	22L				ΡΣ-003613	42L			
ΡΣ-003511	28L				ΡΣ-003614	6S			
ΡΣ-003512	35L				ΡΣ-003615	8S			
ΡΣ-003513	42L				ΡΣ-003616	10S			
ΡΣ-003514	6S				ΡΣ-003617	12S			
ΡΣ-003515	8S				ΡΣ-003618	14S			
ΡΣ-003516	10S				ΡΣ-003619	16S			
ΡΣ-003517	12S				ΡΣ-003620	20S			
ΡΣ-003518	14S				ΡΣ-003621	25S			
ΡΣ-003519	16S				ΡΣ-003622	30S			
ΡΣ-003520	20S				ΡΣ-003623	38S			
ΡΣ-003521	25S								
ΡΣ-003522	30S								
ΡΣ-003523	38S								

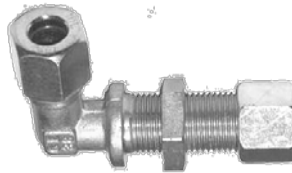
**ΓΩΝΙΑ
ΚΟΝΤΡΑ****ΓΩΝΙΑ Α-Α
ΣΥΝΔΕΣΜΟΣ**

ΚΩΔΙΚΟΣ	ΣΙΔ/ΝΑ	ΣΚΕΤΟ	ΚΟΜΠΛΕ	+ΦΠΑ	ΚΩΔΙΚΟΣ	ΣΙΔ/ΝΑ	ΣΚΕΤΟ	ΚΟΜΠΛΕ	+ΦΠΑ
ΡΣ-003801	4LL				ΡΣ-003704	6L			
ΡΣ-003802	6LL				ΡΣ-003705	8L			
ΡΣ-003803	8LL				ΡΣ-003706	10L			
ΡΣ-003804	6L				ΡΣ-003707	12L			
ΡΣ-003805	8L				ΡΣ-003708	15L			
ΡΣ-003806	10L				ΡΣ-003709	18L			
ΡΣ-003807	12L				ΡΣ-003710	22L			
ΡΣ-003808	15L				ΡΣ-003711	28L			
ΡΣ-003809	18L				ΡΣ-003712	35L			
ΡΣ-003810	22L				ΡΣ-003713	42L			
ΡΣ-003811	28L				ΡΣ-003714	6S			
ΡΣ-003812	35L				ΡΣ-003715	8S			
ΡΣ-003813	42L				ΡΣ-003716	10S			
ΡΣ-003814	6S				ΡΣ-003717	12S			
ΡΣ-003815	8S				ΡΣ-003718	14S			
ΡΣ-003816	10S				ΡΣ-003719	16S			
ΡΣ-003817	12S				ΡΣ-003720	20S			
ΡΣ-003818	14S				ΡΣ-003721	25S			
ΡΣ-003819	16S				ΡΣ-003722	30S			
ΡΣ-003820	20S				ΡΣ-003723	38S			
ΡΣ-003821	25S								
ΡΣ-003822	30S								
ΡΣ-003823	38S								





ΤΑΦ ΣΤΑΘΕΡΑ Α-Α-Α

ΚΩΔΙΚΟΣ	ΣΙΔ/ΝΑ	ΣΚΕΤΟ	ΚΟΜΠΛΕ	+ΦΠΑ
PΣ-003901	4LL			
PΣ-003902	6LL			
PΣ-003903	8LL			
PΣ-003904	6L			
PΣ-003905	8L			
PΣ-003906	10L			
PΣ-003907	12L			
PΣ-003908	15L			
PΣ-003909	18L			
PΣ-003910	22L			
PΣ-003911	28L			
PΣ-003912	35L			
PΣ-003913	42L			
PΣ-003914	6S			
PΣ-003915	8S			
PΣ-003916	10S			
PΣ-003917	12S			
PΣ-003918	14S			
PΣ-003919	16S			
PΣ-003920	20S			
PΣ-003921	25S			
PΣ-003922	30S			
PΣ-003923	38S			



ΣΤΑΥΡΟΙ

ΚΩΔΙΚΟΣ	ΣΙΔ/ΝΑ	ΣΚΕΤΟ	ΚΟΜΠΛΕ	+ΦΠΑ
PΣ-004004	6L			
PΣ-004005	8L			
PΣ-004006	10L			
PΣ-004007	12L			
PΣ-004008	15L			
PΣ-004009	18L			
PΣ-004010	22L			
PΣ-004017	12S			
PΣ-004018	14S			
PΣ-004019	16S			
PΣ-004020	20S			
PΣ-004021	25S			
PΣ-004022	30S			
PΣ-004023	38S			



ΓΩΝΙΕΣ ΤΡΕΛΛΕΣ Α-Θ



ΚΑΒΙΛΙΑ
& O/R

ΕΝΙΣΧΥΜΕΝΑ				
ΚΩΔΙΚΟΣ	ΣΙΔ/ΝΑ	ΣΚΕΤΟ	ΚΟΜΠΛΕ	+ΦΠΑ
PΣ-004204	6L			
PΣ-004205	8L			
PΣ-004206	10L			
PΣ-004207	12L			
PΣ-004208	15L			
PΣ-004209	18L			
PΣ-004210	22L			
PΣ-004211	28L			
PΣ-004212	35L			
PΣ-004213	42L			
PΣ-004214	6S			
PΣ-004215	8S			
PΣ-004216	10S			
PΣ-004217	12S			
PΣ-004218	14S			
PΣ-004219	16S			
PΣ-004220	20S			
PΣ-004221	25S			
PΣ-004222	30S			
PΣ-004223	38S			

ΑΜΒΛΙΕΣ ΤΡΕΛΛΕΣ Α-Θ

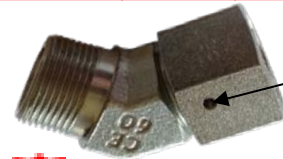

ΚΑΒΙΛΙΑ
& O/R

ΕΝΙΣΧΥΜΕΝΑ				
ΚΩΔΙΚΟΣ	ΣΙΔ/ΝΑ	ΣΚΕΤΟ	ΚΟΜΠΛΕ	+ΦΠΑ
PΣ-005504	6L			
PΣ-005505	8L			
PΣ-005506	10L			
PΣ-005507	12L			
PΣ-005508	15L			
PΣ-005509	18L			
PΣ-005510	22L			
PΣ-005511	28L			
PΣ-005512	35L			
PΣ-005513	42L			
PΣ-005514	6S			
PΣ-005515	8S			
PΣ-005516	10S			
PΣ-005517	12S			
PΣ-005518	14S			
PΣ-005519	16S			
PΣ-005520	20S			
PΣ-005521	25S			
PΣ-005522	30S			
PΣ-005523	38S			

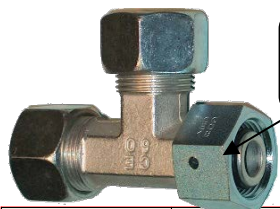

ΚΑΒΙΛΙΑ
& O/R

**ΤΑΦ
ΤΡΕΛΟ ΑΚΡΗ
ΕΝΙΣΧΥΜΕΝΑ**

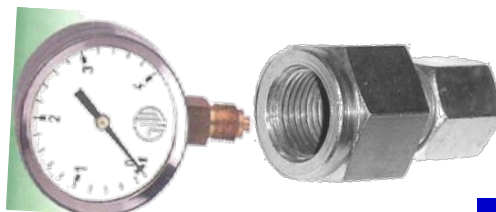

**ΜΑΝΟΜΕΤΡΩΝ
ΑΡΣΕΝΙΚΑ**

ΚΩΔΙΚΟΣ	ΣΙΔ/ΝΑ	ΣΚΕΤΟ	ΚΟΜΠΛΕ	+ΦΠΑ
PΣ-004604	6L			
PΣ-004605	8L			
PΣ-004606	10L			
PΣ-004607	12L			
PΣ-004608	15L			
PΣ-004609	18L			
PΣ-004610	22L			
PΣ-004611	28L			
PΣ-004612	35L			
PΣ-004613	42L			
PΣ-004614	6S			
PΣ-004615	8S			
PΣ-004616	10S			
PΣ-004617	12S			
PΣ-004618	14S			
PΣ-004619	16S			
PΣ-004620	20S			
PΣ-004621	25S			
PΣ-004622	30S			
PΣ-004623	38S			

ΚΩΔΙΚΟΣ	ΣΙΔ/ΝΑ	ΣΚΕΤΟ	ΚΟΜΠΛΕ	+ΦΠΑ
PΣ-005904	6L	1/4		
PΣ-005905	8L			
PΣ-005906	10L			
PΣ-005907	12L			
PΣ-005914	6S	1/2		
PΣ-005915	8S			
PΣ-005916	10S			
PΣ-005917	12S			
PΣ-005900	ΡΟΔΕΛΛΑ 1/4			
PΣ-005901	ΡΟΔΕΛΛΑ 1/2			



NEW

**ΜΑΝΟΜΕΤΡΩΝ
ΘΗΛΥΚΑ**

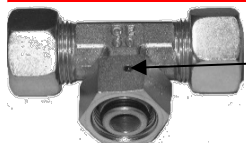

ΚΑΒΙΛΙΑ
& O/R

**ΤΑΦ
ΤΡΕΛΟ ΜΕΣΗ
ΕΝΙΣΧΥΜΕΝΑ**

ΚΩΔΙΚΟΣ	ΣΙΔ/ΝΑ	ΣΚΕΤΟ	ΚΟΜΠΛΕ	+ΦΠΑ
PΣ-005004	6L			
PΣ-005005	8L			
PΣ-005006	10L			
PΣ-005007	12L			
PΣ-005008	15L			
PΣ-005009	18L			
PΣ-005010	22L			
PΣ-005011	28L			
PΣ-005012	35L			
PΣ-005013	42L			
PΣ-005014	6S			
PΣ-005015	8S			
PΣ-005016	10S			
PΣ-005017	12S			
PΣ-005018	14S			
PΣ-005019	16S			
PΣ-005020	20S			
PΣ-005021	25S			
PΣ-005022	30S			
PΣ-005023	38S			

ΚΩΔΙΚΟΣ	ΣΙΔ/ΝΑ	ΚΟΜΠΛΕ	+ΦΠΑ
PΣ-006004	6L	1/4	
PΣ-006005	8L		
PΣ-006006	10L		
PΣ-006007	12L		
PΣ-006014	6S	1/2	
PΣ-006015	8S		
PΣ-006016	10S		
PΣ-006017	12S		

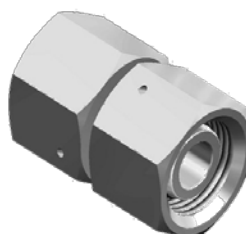

**ΣΥΝΔΕΣΜΟΙ
ΘΗΛΥΚΟ- ΘΗΛΥΚΟ**

PΣ-121212	6L	6L		
PΣ-121414	8L	8L		
PΣ-121616	10L	10L		
PΣ-121818	12L	12L		
PΣ-122222	15L	15L		
PΣ-123030	22L	22L		



ΣΥΝΔΕΣΜΟΙ ΣΥΣΤΟΛΙΚΟΙ

ΚΩΔΙΚΟΣ	ΣΙΑ/ΝΑ	ΣΚΕΤΟ	ΚΟΜΠΛΕ	+ΦΠΑ
PΣ-003400	4LL-6LL			
PΣ-003401	8L-6L			
PΣ-003402	10L-6L			
PΣ-003403	10L-8L			
PΣ-003404	12L-6L			
PΣ-003405	12L-8L			
PΣ-003406	12L-10L			
PΣ-003407	15L-6L			
PΣ-003408	15L-8L			
PΣ-003409	15L-10L			
PΣ-003410	15L-12L			
PΣ-003412	18L-10L			
PΣ-003413	18L-12L			
PΣ-003414	18L-15L			
PΣ-003416	22L-15L			
PΣ-003417	22L-18L			
PΣ-003422	8S-6S			
PΣ-003423	10S-6S			
PΣ-003424	10S-8S			
PΣ-003425	12S-6S			
PΣ-003426	12S-8S			
PΣ-003427	12S-10S			
PΣ-003428	14S-10S			
PΣ-003429	14S-12S			
PΣ-003430	16S-12S			
PΣ-003431	16S-14S			
PΣ-003434	20S-16S			
PΣ-003436	25S-20S			
PΣ-003437	30S-20S			
PΣ-003438	30S-25S			
PΣ-003439	38S-30S			



ΤΑΦ ΜΕΣΗ N.P.T

ΚΩΔΙΚΟΣ	ΣΙΑ/ΝΑ	ΣΚΕΤΟ	ΚΟΜΠΛΕ	+ΦΠΑ
PΣ-002504	6L-1/8			
PΣ-002505	8L-1/4			
PΣ-002506	10L-1/4			
PΣ-002507	12L-3/8			
PΣ-002508	15L-1/2			



ΤΑΦ ΑΚΡΗ N.P.T

ΚΩΔΙΚΟΣ	ΣΙΑ/ΝΑ	ΣΚΕΤΟ	ΚΟΜΠΛΕ	+ΦΠΑ
PΣ-003004	6L-1/8			
PΣ-003005	8L-1/4			
PΣ-003006	10L-1/4			
PΣ-003007	12L-3/8			
PΣ-003008	15L-1/2			



ΚΑΒΙΛΙΑ
& O/R

ΚΟΡ ΣΕΙΡΑ L

ΕΝΙΣΧΥΜΕΝΑ

ΚΩΔΙΚΟΣ	ΘΗΛ-ΑΡΣ	ΣΚΕΤΟ ΑΡΣ	ΚΟΜΠΛΕ	+ΦΠΑ
PΣ-005301	8-6L			
PΣ-005302	10-6L			
PΣ-005303	12-6L			
PΣ-005304	15-6L			
PΣ-005310	10-8L			
PΣ-005311	12-8L			
PΣ-005312	15-8L			
PΣ-005318	12-10L			
PΣ-005319	15-10L			
PΣ-005320	18-10L			
PΣ-005325	15-12L			
PΣ-005326	18-12L			
PΣ-005327	22-12L			
PΣ-005328	28-12L			
PΣ-005329	35-12L			
PΣ-005331	18-15L			
PΣ-005332	22-15L			
PΣ-005333	28-15L			
PΣ-005336	22-18L			
PΣ-005337	28-18L			
PΣ-005340	28-22L			
PΣ-005341	35-22L			
PΣ-005343	35-28L			
PΣ-005345	42-35L			

ΚΟΡ ΣΕΙΡΑ S

ΚΩΔΙΚΟΣ	ΘΗΛ-ΑΡΣ	ΣΚΕΤΟ ΑΡΣ	ΚΟΜΠΛΕ	+ΦΠΑ
PΣ-005401	8-6S			
PΣ-005402	10-6S			
PΣ-005403	12-6S			
PΣ-005410	10-8S			
PΣ-005411	12-8S			
PΣ-005412	14-8S			
PΣ-005413	16-8S			
PΣ-005418	12-10S			
PΣ-005419	14-10S			
PΣ-005420	16-10S			
PΣ-005421	20-10S			
PΣ-005425	14-12S			
PΣ-005426	16-12S			
PΣ-005427	20-12S			
PΣ-005428	25-12S			
PΣ-005429	30-12S			
PΣ-005431	16-14S			
PΣ-005432	20-14S			
PΣ-005436	20-16S			
PΣ-005437	25-16S			
PΣ-005438	30-16S			
PΣ-005440	25-20S			
PΣ-005441	30-20S			
PΣ-005443	30-25S			
PΣ-005444	38-25S			
PΣ-005445	38-30S			

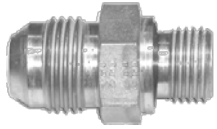

ΜΑΣΤΟΙ

UNF- BSP & O/R

ΚΩΔΙΚΟΣ	ΣΠΕΙΡΩΜΑ	ΒΑΣΗ	€	+ΦΠΑ
AM-011103	7/16X20	1\8		
AM-011106		1\4		
AM-011110		3\8		
AM-011113		1\2		
AM-011303	1/2X20	1\8		
AM-011306		1\4		
AM-011310		3\8		
AM-011403	9/16X18	1\8		
AM-011406		1\4		
AM-011410		3\8		
AM-011413		1\2		
AM-011906	3/4X16	1\4		
AM-011910		3\8		
AM-011913		1\2		
AM-011919		3\4		
AM-012210	7/8X14	3\8		
AM-012213		1\2		
AM-012219		3\4		
AM-012710	1"1/16	3\8		
AM-012713		1\2		
AM-012719		3\4		
AM-012725		1"		
AM-013319	1"5/16	3\4		
AM-013325		1"		
AM-013332		1"¼		
AM-014125	1"5/8	1"		
AM-014132		1"¼		
AM-014138		1"½		
AM-014732	1"7/8	1"¼		
AM-014738		1"½		



ΜΑΣΤΟΙ

UNF- N.P.T

ΚΩΔΙΚΟΣ	ΣΠΕΙΡΩΜΑ	ΒΑΣΗ	€	+ΦΠΑ
AM-021103	7/16X20	1\8		
AM-021106		1\4		
AM-021110		3\8		
AM-021113		1\2		
AM-021303	1/2X20	1\8		
AM-021306		1\4		
AM-021403	9/16X18	1\8		
AM-021406		1\4		
AM-021410		3\8		
AM-021413		1\2		
AM-021906	3/4X16	1\4		
AM-021910		3\8		
AM-021913		1\2		
AM-021919		3\4		
AM-022210	7/8X14	3\8		
AM-022213		1\2		
AM-022219		3\4		
AM-022713	1"1/16	1\2		
AM-022719		3\4		
AM-022725		1"		
AM-023319	1"5/16	3\4		
AM-023325		1"		
AM-024125	1"5/8	1"		
AM-024132		1"¼		
AM-024732	1"7/8	1"¼		
AM-024738		1"½		



ΜΑΣΤΟΙ

UNF-ΜΕΤΡΙΚΟ

ΚΩΔΙΚΟΣ	ΣΠΕΙΡΩΜΑ	ΒΑΣΗ	€	+ΦΠΑ
AM-191110	7/16X20	10X1		
AM-191310	1/2X20			
AM-191112	7/16X20	12X1,5		
AM-191312	1/2X20			
AM-191314	1/2X20	14X1,5		
AM-191414	9/16X18			
AM-191914	3/4X16			
AM-191416	9/16X18	16X1,5		
AM-191916	3/4X16			
AM-191918	3/4X16	18X1,5		
AM-192218	7/8X14			
AM-192220	7/8X14	20X1,5		
AM-192222	7/8X14			
AM-192722	1"1/16	22X1,5		
AM-192727	1"1/16			
AM-193327	1"5/16			



ΜΑΣΤΟΙ

UNF ΠΡΟΕΚΤΑΣΗ ΒΑΣΗ B.S.P.

ΚΩΔΙΚΟΣ	ΠΡΟΕΚΤΑΣΗ	ΒΑΣΗ	€	+ΦΠΑ
AM-621306	1/2X20	1\4		
AM-621406	9\16	1\4		
AM-621410		3\8		
AM-621910	3/4X16	3\8		
AM-621913		1\2		
AM-622213	7\8	1\2		
AM-622219		3\4		
AM-622713	1"1/16	1\2		
AM-622719		3\4		
AM-623325	1"5/16	1"		
AM-624132	1"5/8	1"1/4		



ΜΑΣΤΟΙ
UNF - UNF & O/R



ΑΝΤΙΣΤΡΟΦΑ
UNF- BSP & O/R

ΚΩΔΙΚΟΣ	ΣΠΕΙΡΩΜΑ	ΒΑΣΗ	€	+ΦΠΑ
AM-031111	7/16X20	7/16X20		
AM-031114	9/16X18			
AM-031311	7/16X20	1/2X20		
AM-031313	1/2X20			
AM-031314	9/16X18	9/16X18		
AM-031411	7/16X20			
AM-031413	1/2X20			
AM-031414	9/16X18			
AM-031419	3/4X16			
AM-031911	7/16X20	3/4X16		
AM-031914	9/16X18			
AM-031919	3/4X16			
AM-031922	7/8X14			
AM-031927	1"1/16	7/8X14		
AM-032214	9/16X18			
AM-032219	3/4X16			
AM-032222	7/8X14			
AM-032227	1"1/16			
AM-032233	1"5/16	1"1/16		
AM-032719	3/4X16			
AM-032722	7/8X14			
AM-032727	1"1/16			
AM-032733	1"5/16	1"5/16		
AM-033327	1"1/16			
AM-033333	1"5/16			
AM-033341	1"5/8	1"5/8		
AM-034133	1"5/16			
AM-034141	1"5/8			
AM-034147	1"7/8			
AM-034747	1"7/8	1"7/8		

ΚΩΔΙΚΟΣ	ΣΠΕΙΡΩΜΑ	ΒΑΣΗ	€	+ΦΠΑ
AM-041103	7/16X20	1\8		
AM-041106		1\4		
AM-041110		3\8		
AM-041303	1/2X20	1\8		
AM-041306		1\4		
AM-041310		3\8		
AM-041406	9/16X18	1\4		
AM-041410		3\8		
AM-041413		1\2		
AM-041906	3/4X16	1\4		
AM-041910		3\8		
AM-041913		1\2		
AM-042210	7/8X14	3\8		
AM-042213		1\2		
AM-042219		3\4		
AM-042713	1"1/16	1\2		
AM-042719		3\4		
AM-042725		1"		
AM-043319	1"5/16	3\4		
AM-043325		1"		
AM-043332		1"¼		
AM-044125	1"5/8	1"		
AM-044132		1"¼		
AM-044732	1"7/8	1"¼		
AM-044738		1"½		



ΑΝΤΙΣΤΡΟΦΑ
UNF- N.P.T

ΚΩΔΙΚΟΣ	ΣΠΕΙΡΩΜΑ	ΒΑΣΗ	€	+ΦΠΑ
AM-051103	7/16X20	1\8		
AM-051106		1\4		
AM-051303		1\8		
AM-051306	1/2X20	1\4		
AM-051403	9/16X18	1\8		
AM-051406		1\4		
AM-051410		3\8		
AM-051413	3/4X16	1\2		
AM-051906		1\4		
AM-051910		3\8		
AM-051913	7/8X14	1\2		
AM-051919		3\4		
AM-052210		3\8		
AM-052213	1"1/16	1\2		
AM-052219		3\4		
AM-052713		1\2		
AM-052719	1"5/16	3\4		
AM-053319		3\4		
AM-053325		1"		
AM-054125	1"5/8	1"		
AM-054132		1"¼		
AM-054738	1"7/8	1"½		

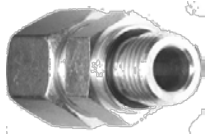

ΜΑΣΤΟΙ
ΒΑΣΗ UNF- L & S

ΚΩΔΙΚΟΣ	ΒΑΣΗ	ΣΙΔ/ΝΑ	ΣΚΕΤΑ	+ΦΠΑ
AM-181106	7/16 X20	6L		
AM-181108		8L		
AM-181110		10L		
AM-181308	1/2X20	8L		
AM-181310		10L		
AM-181412	9\16X18	12L		
AM-181912	3/4X16	12L		
AM-181915		15L		
AM-181916		16S		
AM-181918		18L		
AM-182212	7/8X14	12L		
AM-182215		15L		
AM-182218		18L		
AM-182722	1"1/16	22L		
AM-182720		20S		





ΑΝΤΙΣΤΡΟΦΑ UNF- ΒΑΣΗ UN.F

ΚΩΔΙΚΟΣ	ΒΑΣΗ	ΤΡΕΛΛΟ	€	+ΦΠΑ
AM-061111	7/16X20	7/16X20		
AM-061311	1/2X20	7/16X20		
AM-061313		1/2X20		
AM-061411	9/16	7/16X20		
AM-061414		9/16		
AM-061914	3/4X16	9/16		
AM-061919		3/4X16		
AM-061922		7/8X14		
AM-061927		1"1/16		
AM-062219		7/8	3/4X16	
AM-062222	7/8X14			
AM-062227	1"1/16			
AM-062719	1"1/16	3/4X16		
AM-062722		7/8X14		
AM-062727		1"1/16		
AM-062733		1"5/16		
AM-063327	1"5/16	1"1/16		
AM-063333		1"5/16		
AM-064133	1"5/8	1"5/16		
AM-064141		1"5/8		
AM-064747	1"7/8	1"7/8		



ΓΩΝΙΕΣ UNF- NPT

ΚΩΔΙΚΟΣ	ΣΠΕΙΡΩΜΑ	ΒΑΣΗ	€	+ΦΠΑ
AM-071103	7/16X20	1\8		
AM-071106		1\4		
AM-071110		3\8		
AM-071113		1\2		
AM-071303	1/2X20	1\8		
AM-071306		1\4		
AM-071403	9/16X18	1\8		
AM-071406		1\4		
AM-071410		3\8		
AM-071413		1\2		
AM-071906	3/4X16	1\4		
AM-071910		3\8		
AM-071913		1\2		
AM-071919		3\4		
AM-072210	7/8X14	3\8		
AM-072213		1\2		
AM-072219		3\4		
AM-072713	1"1/16	1\2		
AM-072719		3\4		
AM-072725		1"		
AM-073319		1"5/16	3\4	
AM-073325	1"			
AM-073332	1"1/4			
AM-074125	1"5/8	1"		
AM-074132		1"1/4		
AM-074138		1"1/2		
AM-074732	1"7/8	1"1/4		
AM-074738		1"1/2		



ΑΝΤΙΣΤΡΟΦΑ UNF ΑΡΣ-ΘΗΛ ΤΡΕΛΛΟ

ΚΩΔΙΚΟΣ	ΑΡΣΕΝΙΚΟ	ΘΗΛΥΚΟ	€	+ΦΠΑ
AM-220014	9\16	9\16		
AM-220019	3/4X16	3/4X16		
AM-220022	7\8	7\8		
AM-221114	7\16	9\16		
AM-221411	9\16	7\16		
AM-221922	3/4X16	7\8		



ΑΜΒΛΙΕΣ UNF- ΒΑΣΗ NPT

ΚΩΔΙΚΟΣ	ΣΠΕΙΡΩΜΑ	ΒΑΣΗ	€	+ΦΠΑ
AM-101103	7/16X20	1\8		
AM-101106		1\4		
AM-101303	1/2X20	1\8		
AM-101306		1\4		
AM-101403	9/16X18	1\8		
AM-101406		1\4		
AM-101410		3\8		
AM-101413		1\2		
AM-101906		3/4X16	1\4	
AM-101910	3\8			
AM-101913	1\2			
AM-101919	3\4			
AM-102210	7/8X14	3\8		
AM-102213		1\2		
AM-102219		3\4		
AM-102713	1"1/16	1\2		
AM-102719		3\4		
AM-102725		1"		
AM-103319	1"5/16	3\4		
AM-103325		1"		
AM-104125	1"5/8	1"		
AM-104132		1"1/4		
AM-104738	1"7/8	1"1/2		



ΣΥΝΔΕΣΜΟΙ UNF

ΚΩΔΙΚΟΣ	ΣΠΕΙΡΩΜΑ	€	+ΦΠΑ
AM-350909	3/8X24		
AM-351111	7/16X20		
AM-351313	1/2X20		
AM-351414	9/16X18		
AM-351616	5/8X18		
AM-351919	3/4X16		
AM-352222	7/8X14		
AM-352727	1"1/16		
AM-353030	1"3/16		
AM-353333	1"5/16		
AM-354141	1"5/8		
AM-354747	1"7/8		
ΣΥΝΔΕΣΜΟΙ ΣΥΣΤΟΛΙΚΟΙ UNF			
AM-351411	9/16	7/16	
AM-351914	3/4x16	9/16	
AM-352219	7/8	3/4x16	
AM-352719	1"1/16	3/4x16	
AM-352722	1"1/16	7/8	
AM-353327	1"5/16	1"1/16	



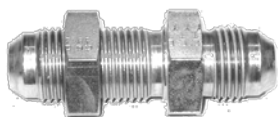

**ΣΥΝΔΕΣΜΟΙ
ΚΟΝΤΡΑ UNF**

ΚΩΔΙΚΟΣ	ΔΙΑΣΤΑΣΗ	€	+ΦΠΑ
AM-360909	3/8X24		
AM-361111	7/16		
AM-361313	1/2X20		
AM-361414	9/16		
AM-361919	3/4X16		
AM-362222	7/8		
AM-362727	1"1/16		
AM-363333	1"5/16		
AM-364141	1"5/8		
AM-364747	1"7/8		



**ΓΩΝΙΕΣ UNF
ΒΑΣΗ ΚΟΝΤΡΑ B.S.P.**

ΚΩΔΙΚΟΣ	ΣΠΕΙΡΩΜΑ	ΒΑΣΗ	€	+ΦΠΑ
AM-081103	7/16X20	1\8		
AM-081106		1\4		
AM-081110		3\8		
AM-081113		1\2		
AM-081303	1/2X20	1\8		
AM-081306		1\4		
AM-081310		3\8		
AM-081406	9/16X18	1\4		
AM-081410		3\8		
AM-081413		1\2		
AM-081906	3/4X16	1\4		
AM-081910		3\8		
AM-081913		1\2		
AM-081919		3\4		
AM-082210	7/8X14	3\8		
AM-082213		1\2		
AM-082219		3\4		
AM-082713	1"1/16	1\2		
AM-082719		3\4		
AM-082725		1"		
AM-083319	1"5/16	3\4		
AM-083325		1"		
AM-083332		1"1\4		
AM-084125	1"5/8	1"		
AM-084132		1"1\4		
AM-084732	1"7/8	1"1\4		
AM-084738		1"1\2		



**ΣΥΝΔΕΣΜΟΙ
ΓΩΝΙΕΣ ΚΟΝΤΡΑ UNF**

AM-371111	7/16X20		
AM-371313	1/2X20		
AM-371414	9/16		
AM-371919	3/4X16		
AM-372222	7/8		
AM-372727	1"1/16		
AM-373333	1"5/16		
AM-374141	1"5/8		
AM-374747	1"7/8		



ΠΑΞΙΜΑΔΙΑ UNF

ΚΩΔΙΚΟΣ	ΣΠΕΙΡΩΜΑ	€	+ΦΠΑ
AM-161106	7/16X20		
AM-161308	1/2X20		
AM-161410	9/16X18		
AM-161912	3/4X16		
AM-162215	7/8X14		
AM-162720	1"1/16		
AM-163325	1"5/16		
AM-164130	1"5/8		
AM-164738	1"7/8		

ΟΔΗΓΟΙ ΣΙΔΗΡΟΣΩΛΗΝΩΝ

ΚΩΔΙΚΟΣ	ΣΠΕΙΡΩΜΑ	ΣΙΔ/ΝΑ	€	+ΦΠΑ
AM-171106	7/16X20	6		
AM-171308	1/2X20	8		
AM-171410	9/16X18	10		
AM-171912	3/4X16	12		
AM-172214	7/8X14	14		
AM-172215	7/8X14	15		
AM-172216	7/8X14	16		
AM-172718	1"1/16	18		
AM-172720	1"1/16	20		
AM-173325	1"5/16	25		
AM-174130	1"5/8	30		
AM-174738	1"7/8	38		



**ΓΩΝΙΕΣ UNF
ΚΟΝΤΡΑ ΜΕΤΡΙΚΟ**

ΚΩΔΙΚΟΣ	ΣΠΕΙΡΩΜΑ	ΒΑΣΗ	€	+ΦΠΑ
AM-201110	7/16X20	10X1		
AM-201112		12X1,5		
AM-201310	1/2X20	10X1		
AM-201312		12X1,5		
AM-201314		14X1,5		
AM-201414	9/16X18	14X1,5		
AM-201416		16X1,5		
AM-201916	3/4X16	16X1,5		
AM-201918		18X1,5		
AM-202218	7/8X14	18X1,5		
AM-202220		20X1,5		
AM-202222		22X1,5		
AM-202722	1"1/16	22X1,5		
AM-202727		27X2		
AM-203327	1"5/16	27X2		
AM-203333		33X2		
AM-204142	1"5/8	42X2		



ΓΩΝΙΕΣ UNF
ΒΑΣΗ ΚΟΝΤΡΑ UNF

ΚΩΔΙΚΟΣ	ΣΠΕΙΡΩΜΑ	ΒΑΣΗ	€	+ΦΠΑ
AM-091111	7/16X20	7/16X20		
AM-091311	7/16X20			
AM-091313	1/2X20	1/2X20		
AM-091314	9/16X18			
AM-091411	7/16X20			
AM-091413	1/2X20	9/16X18		
AM-091414	9/16X18			
AM-091419	3/4X16			
AM-091914	9/16X18			
AM-091919	3/4X16	3/4X16		
AM-091922	7/8X14			
AM-091927	1"1/16			
AM-092214	9/16X18			
AM-092219	3/4X16	7/8X14		
AM-092222	7/8X14			
AM-092227	1"1/16			
AM-092719	3/4X16			
AM-092722	7/8X14			
AM-092727	1"1/16	1"1/16		
AM-092733	1"5/16			
AM-093327	1"1/16	1"5/16		
AM-093333	1"5/16			
AM-094133	1"5/16	1"5/8		
AM-094141	1"5/8			
AM-094747	1"7/8	1"7/8		



ΑΜΒΛΙΕΣ UNF
ΒΑΣΗ ΚΟΝΤΡΑ B.S.P.

ΚΩΔΙΚΟΣ	ΣΠΕΙΡΩΜΑ	ΒΑΣΗ	€	+ΦΠΑ
AM-111103		1\8		
AM-111106	7/16X20	1\4		
AM-111110		3\8		
AM-111113		1\2		
AM-111303		1\8		
AM-111306	1/2X20	1\4		
AM-111310		3\8		
AM-111406		1\4		
AM-111410	9/16X18	3\8		
AM-111413		1\2		
AM-111906		1\4		
AM-111910	3/4X16	3\8		
AM-111913		1\2		
AM-111919		3\4		
AM-112210		3\8		
AM-112213	7/8X14	1\2		
AM-112219		3\4		
AM-112713		1\2		
AM-112719	1"1/16	3\4		
AM-112725		1"		
AM-113319		3\4		
AM-113325	1"5/16	1"		
AM-113332		1"1\4		
AM-114125		1"		
AM-114132	1"5/8	1"1\4		
AM-114732		1"1\4		
AM-114738	1"7/8	1"1\2		



ΑΜΒΛΙΕΣ UNF
ΒΑΣΗ ΚΟΝΤΡΑ UNF

ΚΩΔΙΚΟΣ	ΣΠΕΙΡΩΜΑ	ΒΑΣΗ	€	+ΦΠΑ
AM-121111	7/16X20	7/16X20		
AM-121311	7/16X20			
AM-121313	1/2X20	1/2X20		
AM-121414	9/16X18	9/16X18		
AM-121914	9/16X18			
AM-121919	3/4X16	3/4X16		
AM-121922	7/8X14			
AM-121927	1"1/16			
AM-122219	3/4X16	7/8X14		
AM-122222	7/8X14			
AM-122227	1"1/16			
AM-122727	1"1/16	1"1/16		
AM-122733	1"5/16			
AM-123327	1"1/16	1"5/16		
AM-123333	1"5/16			
AM-124133	1"5/16	1"5/8		
AM-124141	1"5/8			
AM-124747	1"7/8	1"7/8		



ΑΜΒΛΙΕΣ UNF
ΚΟΝΤΡΑ ΜΕΤΡΙΚΟ

ΚΩΔΙΚΟΣ	ΣΠΕΙΡΩΜΑ	ΒΑΣΗ	€	+ΦΠΑ
AM-211110		10X1		
AM-211112	7/16X20	12X1,5		
AM-211310		10X1		
AM-211312	1/2X20	12X1,5		
AM-211314		14X1,5		
AM-211414	9/16X18	14X1,5		
AM-211416		16X1,5		
AM-211916	3/4X16	16X1,5		
AM-211918		18X1,5		
AM-212218		18X1,5		
AM-212220	7/8X14	20X1,5		
AM-212222		22X1,5		
AM-212722	1"1/16	22X1,5		
AM-212727		27X2		
AM-213327	1"5/16	27X2		
AM-213333		33X2		
AM-214142	1"5/8	42X2		



ΓΩΝΙΕΣ ΤΡΕΛΕΣ Α-Θ				ΑΜΒΛΕΙΕΣ ΤΡΕΛΕΣ Α-Θ				ΓΩΝΙΕΣ UNF Α-Α			
ΚΩΔΙΚΟΣ	ΣΠΕΙΡΩΜΑ	€	+ΦΠΑ	ΚΩΔΙΚΟΣ	ΣΠΕΙΡΩΜΑ	€	+ΦΠΑ	ΚΩΔΙΚΟΣ	ΣΠΕΙΡΩΜΑ	€	+ΦΠΑ
AM-421111	7/16X20			AM-131111	7/16X20			AM-381111	7/16X20		
AM-421313	1/2X20			AM-131313	1/2X20			AM-381313	1/2X20		
AM-421414	9/16X18			AM-131414	9/16X18			AM-381414	9/16X18		
AM-421919	3/4X16			AM-131919	3/4X16			AM-381919	3/4X16		
AM-422222	7/8X14			AM-132222	7/8X14			AM-382222	7/8X14		
AM-422727	1"1/16			AM-132727	1"1/16			AM-382727	1"1/16		
AM-423333	1"5/16			AM-133333	1"5/16			AM-383333	1"5/16		
AM-424141	1"5/8			AM-134141	1"5/8			AM-384141	1"5/8		
AM-424747	1"7/8			AM-134747	1"7/8			AM-384747	1"7/8		

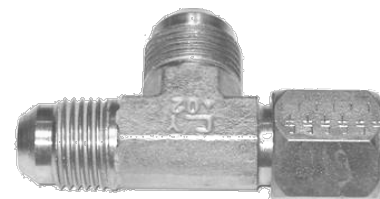
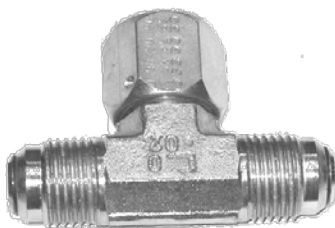

ΤΑΦ UNF Α-Α-Α				ΤΑΦ UNF Α-Θ-Α				ΤΑΦ UNF Α-Α-Θ			
ΚΩΔΙΚΟΣ	ΣΠΕΙΡΩΜΑ	€	+ΦΠΑ	ΚΩΔΙΚΟΣ	ΣΠΕΙΡΩΜΑ	€	+ΦΠΑ	ΚΩΔΙΚΟΣ	ΣΠΕΙΡΩΜΑ	€	+ΦΠΑ
AM-391111	7/16X20			AM-501111	7/16X20			AM-461111	7/16X20		
AM-391313	1/2X20			AM-501313	1/2X20			AM-461313	1/2X20		
AM-391414	9/16X18			AM-501414	9/16X18			AM-461414	9/16X18		
AM-391919	3/4X16			AM-501919	3/4X16			AM-461919	3/4X16		
AM-392222	7/8X14			AM-502222	7/8X14			AM-462222	7/8X14		
AM-392727	1"1/16			AM-502727	1"1/16			AM-462727	1"1/16		
AM-393333	1"5/16			AM-503333	1"5/16			AM-463333	1"5/16		
AM-394141	1"5/8			AM-504141	1"5/8			AM-464141	1"5/8		
AM-394747	1"7/8			AM-504747	1"7/8			AM-464747	1"7/8		



ΤΑΠΕΣ ΘΗΛΥΚΕΣ UNF				ΤΑΠΕΣ ΑΡΣΕΝΙΚΕΣ UNF				ΤΑΠΕΣ ALLEN UNF			
ΚΩΔΙΚΟΣ	ΣΠΕΙΡΩΜΑ	€	+ΦΠΑ	ΚΩΔΙΚΟΣ	ΣΠΕΙΡΩΜΑ	€	+ΦΠΑ	ΚΩΔΙΚΟΣ	ΣΠΕΙΡΩΜΑ	€	+ΦΠΑ
AM-150011	7/16X20			AM-140011	7/16X20			AM-170011	7/16X20		
AM-150013	1/2X20			AM-140013	1/2X20			AM-170013	1/2X20		
AM-150014	9/16X18			AM-140014	9/16X18			AM-170014	9/16X18		
AM-150019	3/4X16			AM-140019	3/4X16			AM-170019	3/4X16		
AM-150022	7/8X14			AM-140022	7/8X14			AM-170022	7/8X14		
AM-150027	1"1/16			AM-140027	1"1/16			AM-170027	1"1/16		
AM-150033	1"5/16			AM-140033	1"5/16			AM-170033	1"5/16		
AM-150041	1"5/8			AM-140041	1"5/8			AM-170041	1"5/8		
AM-150047	1"7/8			AM-140047	1"7/8			AM-170047	1"7/8		



ΤΑΦ ΑΚΡΗ

ΒΑΣΗ ΚΟΝΤΡΑ B.S.P.

ΚΩΔΙΚΟΣ	ΣΠΕΙΡΩΜΑ	ΚΟΝΤΡΑ	€	+ΦΠΑ
AM-521103	7/16X20	1\8		
AM-521303	1/2X20	1\8		
AM-521306	1/2X20	1\4		
AM-521406	9/16X18	1\4		
AM-521410	9\16	3\8		
AM-521910	3/4X16	3\8		
AM-521913	3/4X16	1\2		
AM-522213	7/8X14	1\2		
AM-522713	1"1/16	1\2		
AM-522719	1"1/16	3\4		
AM-523325	1"5/16	1"		
AM-524132	1"5/8	1"1/4		



ΤΑΦ ΑΚΡΗ

ΒΑΣΗ ΚΟΝΤΡΑ UNF

ΚΩΔΙΚΟΣ	ΣΠΕΙΡΩΜΑ	ΚΟΝΤΡΑ	€	+ΦΠΑ
AM-530011	7/16X20	7/16X20		
AM-530013	1/2X20	1/2X20		
AM-530014	9/16X18	9/16X18		
AM-531914	9/16X18	3/4X16		
AM-530019	3/4X16	3/4X16		
AM-531922	7/8X14	3/4X16		
AM-532219	3/4X16	7/8X14		
AM-530022	7/8X14	7/8X14		
AM-532227	1"1/16	7/8X14		
AM-530027	1"1/16	1"1/16		
AM-530033	1"5/16	1"5/16		



ΤΑΦ ΜΕΣΗ

ΒΑΣΗ ΚΟΝΤΡΑ B.S.P.

ΚΩΔΙΚΟΣ	ΣΠΕΙΡΩΜΑ	ΚΟΝΤΡΑ	€	+ΦΠΑ
AM-541103	7/16X20	1\8		
AM-541303	1/2X20	1\8		
AM-541306	1/2X20	1\4		
AM-541406	9/16X18	1\4		
AM-541410	9\16	3\8		
AM-541910	3/4X16	3\8		
AM-541913	3/4X16	1\2		
AM-542213	7/8X14	1\2		
AM-542713	1"1/16	1\2		
AM-542719	1"1/16	3\4		
AM-543325	1"5/16	1"		
AM-544132	1"5/8	1"1/4		



ΤΑΦ ΜΕΣΗ

ΒΑΣΗ ΚΟΝΤΡΑ UNF

ΚΩΔΙΚΟΣ	ΣΠΕΙΡΩΜΑ	ΚΟΝΤΡΑ	€	+ΦΠΑ
AM-551111	7/16X20	7/16X20		
AM-551313	1/2X20	1/2X20		
AM-551414	9/16X18	9/16X18		
AM-551914	9/16X18	3/4X16		
AM-551919	3/4X16	3/4X16		
AM-551922	7/8X14	3/4X16		
AM-552219	3/4X16	7/8X14		
AM-552222	7/8X14	7/8X14		
AM-552227	1"1/16	7/8X14		
AM-552727	1"1/16	1"1/16		
AM-553333	1"5/16	1"5/16		



ΑΓΓΛΙΑΣ

ΑΡΣ BSP-ΘΗΛ UNF

ΚΩΔΙΚΟΣ	ΑΡΣΕΝΙΚΟ	ΘΗΛΥΚΟ	€	+ΦΠΑ
ΡΣ-007532	3\4	1"1\16		
ΡΣ-007533	1"	1"5\16		

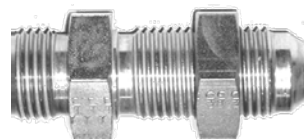

ΜΑΣΤΟΙ B.S.P- ΚΟΝΤΡΑ UNF

ΚΩΔΙΚΟΣ	ΒΑΣΗ	ΚΟΝΤΡΑ	€	+ΦΠΑ
ΡΣ-151319	1\2	3/4X16		
ΡΣ-151322	1\2	7/8X14		
AM-232719	3\4	1"1/16		
AM-233325	1"	1"5/16		



ΣΕΙΡΑ O.R.F.S.



**ΜΑΣΤΟΙ O.R.F.S.
ΒΑΣΗ B.S.P**

ΚΩΔΙΚΟΣ	O.R.F.S.	ΒΑΣΗ	€	+ΦΠΑ
OP-011403	9/16x18	1/8		
OP-011406		1/4		
OP-011410		3/8		
OP-011413		1/2		
OP-011703	11/16x16	1/8		
OP-011706		1/4		
OP-011710		3/8		
OP-011713		1/2		
OP-011719		3/4		
OP-012106	13/16x16	1/4		
OP-012110		3/8		
OP-012113		1/2		
OP-012119		3/4		
OP-012510	1" x 14	3/8		
OP-012513		1/2		
OP-012519		3/4		
OP-012525		1"		
OP-013013	1" 3/16x12	1/2		
OP-013019		3/4		
OP-013025		1"		
OP-013032		1" 1/4		
OP-013719	1" 7/16x12	3/4		
OP-013725		1"		
OP-013732		1" 1/4		
OP-014225	1" 11/16x12	1"		
OP-014232		1" 1/4		
OP-014238		1" 1/2		



ΜΑΣΤΟΙ O.R.F.S ΠΡΟΕΚΤΑΣΗ-ΒΑΣΗ B.S.P

OP-060314	9/16	1/8		
OP-060614		1/4		
OP-060617	11/16	1/4		
OP-061017		3/8		
OP-061317		1/2		
OP-061020	13/16	3/8		
OP-061320		1/2		
OP-061325	1"X14	1/2		
OP-061925		3/4		
OP-061330	1"3/16	1/2		
OP-061930		3/4		
OP-062530		1"		
OP-062537	1"7/16	1"		



**ΑΝΤΙΣΤΡΟΦΑ ΘΗΛ
O.R.F.S-ΑΡΣ.Β.S.P**

**B.S.P
60°**



ΚΩΔΙΚΟΣ	O.R.F.S. ΘΗΛ.	ΒΑΣΗ	€	+ΦΠΑ
OP-041403	9/16	1/8		
OP-041406		1/4		
OP-041706	11/16	1/4		
OP-041710		3/8		
OP-041713		1/2		
OP-042010	13/16	3/8		
OP-042013		1/2		
OP-042513	1"X14	1/2		
OP-042519		3/4		
OP-043013	1"3/16	1/2		
OP-043019		3/4		
OP-043025		1"		
OP-043725	1"7/16	1"		



**ΜΑΣΤΟΙ O.R.F.S.
ΒΑΣΗ U.N.F.**

ΚΩΔΙΚΟΣ	O.R.F.S.	ΒΑΣΗ	€	+ΦΠΑ
OP-021411	9/16x18	7/16x20		
OP-021413		1/2x20		
OP-021414		9/16x18		
OP-021419		3/4x16		
OP-021711	11/16x16	7/16x20		
OP-021713		1/2x20		
OP-021714		9/16x18		
OP-021719		3/4x16		
OP-021722		7/8x14		
OP-021727		1" 1/16x12		
OP-022114	13/16x16	9/16x18		
OP-022119		3/4x16		
OP-022122		7/8x14		
OP-022127		1" 1/16x12		
OP-022133		1" 5/16x12		
OP-022519	1" x 14	3/4x16		
OP-022522		7/8x14		
OP-022527		1" 1/16x12		
OP-023019	1" 3/16x12	3/4x16		
OP-023022		7/8x14		
OP-023027		1" 1/16x12		
OP-023033		1" 5/16x12		
OP-023727	1" 7/16x12	1" 1/16x12		
OP-023733		1" 5/16x12		
OP-023741		1" 5/8x12		
OP-024233	1" 11/16x12	1" 5/16x12		
OP-024241		1" 5/8x12		
OP-024247		1" 7/8x12		
OP-025041		2" x 12	1" 5/8x12	
OP-025047	1" 7/8x12			

**ΜΑΣΤΟΙ O.R.F.S.****ΒΑΣΗ ΜΕΤΡΙΚΟ**

ΚΩΔΙΚΟΣ	ΒΑΣΗ	ΜΕΤΡΟ	€	+ΦΠΑ
OP-041410	9\16	10X1		
OP-041412		12X1,5		
OP-041414		14X1,5		
OP-041714	11\16	14X1,5		
OP-041716		16X1,5		
OP-041718		18X1,5		
OP-042018	13\16	18X1,5		
OP-042522	1"X14	22X1,5		
OP-043027	1"3\16	27X2		
OP-043733	1"7\16	33X2		
OP-044242	1"11\16	42X2		

**ΣΥΝΔΕΣΜΟΙ****O.R.F.S.**

ΚΩΔΙΚΟΣ	O.R.F.S.	€	+ΦΠΑ
OP-351414	9/16x18		
OP-351717	11/16x16		
OP-352121	13/16x16		
OP-352525	1" x 14		
OP-353030	1" 3/16x12		
OP-353737	1" 7/16x12		
OP-354242	1"11/16x12		
OP-355050	2" x 12		

ΣΥΝΔΕΣΜΟΙ ΣΥΣΤΟΛΙΚΟΙ O.R.F.S.

ΚΩΔΙΚΟΣ	O.R.F.S.	€	+ΦΠΑ
OP-351417	9/16x18 11/16x16		
OP-351721	11/16x16 13/16x16		
OP-351730	11/16x16 1" 3/16x12		
OP-352125	13/16x16 1" x 14		
OP-352130	13/16x16 1" 3/16x12		
OP-352530	1" x 14 1" 3/16x12		
OP-353037	1" 3/16x12 1" 7/16x12		
OP-353742	1" 7/16x12 1"11/16x12		

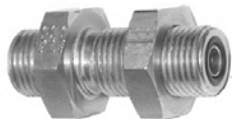
**ΣΥΝΔΕΣΜΟΙ ΚΟΝΤΡΑ****O.R.F.S.**

ΚΩΔΙΚΟΣ	O.R.F.S.	€	+ΦΠΑ
OP-361414	9/16x18		
OP-361717	11/16x16		
OP-362121	13/16x16		
OP-362525	1" x 14		
OP-363030	1" 3/16x12		
OP-363737	1" 7/16x12		
OP-364242	1"11/16x12		
OP-365050	2" x 12		

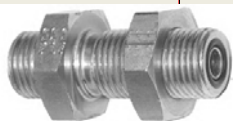
**ΜΑΣΤΟΙ ΒΑΣΗ B.S.P.****ΚΟΝΤΡΑ O.R.F.S.**

ΚΩΔΙΚΟΣ	ΒΑΣΗ	ΚΟΝΤΡΑ	€	+ΦΠΑ
ΡΣ-151320	1\2	13/16 ORFS		
ΡΣ-151325	1\2	1" x 14		
ΡΣ-151925	3\4	1" x 14		
OP-053019	3\4	1" 3/16x12		
OP-053725	1"	1" 7/16x12		

**ΓΩΝΙΑ O.R.F.S.****ΒΑΣΗ N.P.T.F**

ΚΩΔΙΚΟΣ	O.R.F.S.	ΒΑΣΗ	€	+ΦΠΑ
OP-071403	9/16x18	1/8		
OP-071406		1/4		
OP-071410		3/8		
OP-071706	11/16x16	1/4		
OP-071710		3/8		
OP-071713		1/2		
OP-072106	13/16x16	1/4		
OP-072110		3/8		
OP-072113		1/2		
OP-072119	1" x 14	3/4		
OP-072510		3/8		
OP-072513		1/2		
OP-072519	1" 3/16x12	3/4		
OP-073013		1/2		
OP-073019		3/4		
OP-073025	1" 7/16x12	1"		
OP-073719		3/4		
OP-073725		1"		
OP-074225	1"11/16x12	1"		
OP-074232		1" 1/4		
OP-075032		1" 1/4		
OP-075038	2" x 12	1" 1/2		

**ΓΩΝΙΑ A - A**

ΚΩΔΙΚΟΣ	O.R.F.S.	€	+ΦΠΑ
OP-381414	9/16x18		
OP-381717	11/16x16		
OP-382121	13/16x16		
OP-382525	1" x 14		
OP-383030	1" 3/16x12		
OP-383737	1" 7/16x12		
OP-384242	1"11/16x12		
OP-385050	2" x 12		

OP-383020	13/16-1"3/16		
-----------	--------------	--	--

ΗΜΙΓΩΝΙΑ A - A

ΚΩΔΙΚΟΣ	O.R.F.S.	€	+ΦΠΑ
OP-301414	9/16x18		
OP-301717	11/16x16		
OP-302121	13/16x16		
OP-302525	1" x 14		
OP-303030	1" 3/16x12		
OP-303737	1" 7/16x12		
OP-304242	1"11/16x12		
OP-305050	2" x 12		





ΗΜΙΓΩΝΙΑ O.R.F.S

ΚΩΔΙΚΟΣ	O.R.F.S.	ΒΑΣΗ N.P.T.F		
		ΒΑΣΗ	€	+ΦΠΑ
OP-101403	9/16x18	1/8		
OP-101406		1/4		
OP-101410		3/8		
OP-101706	11/16x16	1/4		
OP-101710		3/8		
OP-101713		1/2		
OP-102106	13/16x16	1/4		
OP-102110		3/8		
OP-102113		1/2		
OP-102119		3/4		
OP-102510	1" x 14	3/8		
OP-102513		1/2		
OP-102519		3/4		
OP-103013	1" 3/16x12	1/2		
OP-103019		3/4		
OP-103025		1"		
OP-103719	1" 7/16x12	3/4		
OP-103725		1"		
OP-104225	1"11/16x12	1"		
OP-104232		1" 1/4		
OP-105032	2" x 12	1" 1/4		
OP-105038		1" 1/2		



ΓΩΝΙΑ ORFS

ΒΑΣΗ ΚΟΝΤΡΑ B.S.P

ΚΩΔΙΚΟΣ	O.R.F.S.	ΒΑΣΗ	€	+ΦΠΑ
OP-081403	9/16x18	1/8		
OP-081406		1/4		
OP-081410		3/8		
OP-081706	11/16x16	1/4		
OP-081710		3/8		
OP-081713		1/2		
OP-082106	13/16x16	1/4		
OP-082110		3/8		
OP-082113		1/2		
OP-082119		3/4		
OP-082510	1" x 14	3/8		
OP-082513		1/2		
OP-082519		3/4		
OP-082525		1"		
OP-083013	1" 3/16x12	1/2		
OP-083019		3/4		
OP-083025		1"		
OP-083719	1" 7/16x12	3/4		
OP-083725		1"		
OP-083732		1" 1/4		
OP-084225	1"11/16x12	1"		
OP-084232		1" 1/4		
OP-084238		1" 1/2		

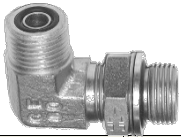

ΓΩΝΙΑ ORFS

ΒΑΣΗ ΚΟΝΤΡΑ U.N.F

ΚΩΔΙΚΟΣ	O.R.F.S.	ΒΑΣΗ	€	+ΦΠΑ
OP-091411	9/16x18	7\16		
OP-091414		9\16		
OP-091419		3/4x16		
OP-091711	11/16x16	7\16		
OP-091714		9\16		
OP-091719		3/4x16		
OP-091722		7\8		
OP-091727	1" 1/16			
OP-092114	13/16x16	9\16		
OP-092119		3/4x16		
OP-092122		7\8		
OP-092127		1" 1/16		
OP-092519	1" x 14	3/4x16		
OP-092522		7\8		
OP-092527		1" 1/16		
OP-093019	1" 3/16x12	3/4x16		
OP-093022		7\8		
OP-093027		1" 1/16		
OP-093033		1" 5/16		
OP-093727	1" 7/16x12	1" 1/16		
OP-093733		1" 5/16		
OP-093741		1" 5/8		
OP-094233	1"11/16x12	1" 5/16		
OP-094241		1" 5/8		
OP-094247		1" 7/8		



ΓΩΝΙΑ ORFS

ΒΑΣΗ ΚΟΝΤΡΑ ΜΕΤΡΙΚΟ

OP-521410	9\16	10X1		
OP-521412		12X1,5		
OP-521714	11\16	14X1,5		
OP-521716		16X1,5		
OP-522017	13\16	16X1,5		
OP-522018		18X1,5		
OP-522022		22X1,5		
OP-522518	1"X14	18X1,5		
OP-522522		22X1,5		
OP-522527		27X2		
OP-523022	1"3\16	22X1,5		
OP-523027		27X2		
OP-523727	1"7\16	27X2		
OP-523733		33X2		
OP-523742		42X2		
OP-524242	1"11\16	42X2		
OP-524248		48X2		





ΗΜΙΓΩΝΙΑ ORFS
ΒΑΣΗ ΚΟΝΤΡΑ Β.Σ.Ρ

ΚΩΔΙΚΟΣ	O.R.F.S.	ΒΑΣΗ	€	+ΦΠΑ
OP-111403	9/16x18	1/8		
OP-111406		1/4		
OP-111410		3/8		
OP-111706	11/16x16	1/4		
OP-111710		3/8		
OP-111713		1/2		
OP-112106	13/16x16	1/4		
OP-112110		3/8		
OP-112113		1/2		
OP-112119		3/4		
OP-112510	1" x 14	3/8		
OP-112513		1/2		
OP-112519		3/4		
OP-112525		1"		
OP-113013	1" 3/16x12	1/2		
OP-113019		3/4		
OP-113025	1" 7/16x12	1"		
OP-113719		3/4		
OP-113725		1"		
OP-113732	1"11/16x12	1" 1/4		
OP-114225		1"		
OP-114232		1" 1/4		
OP-114238		1" 1/2		



ΗΜΙΓΩΝΙΑ ORFS
ΒΑΣΗ ΚΟΝΤΡΑ U.N.F.

ΚΩΔΙΚΟΣ	O.R.F.S.	ΒΑΣΗ	€	+ΦΠΑ
OP-121411	9/16x18	7/16x20		
OP-121414		9/16x18		
OP-121419		3/4x16		
OP-121711	11/16x16	7/16x20		
OP-121714		9/16x18		
OP-121719		3/4x16		
OP-121722		7/8x14		
OP-121727	13/16x16	1" 1/16x12		
OP-122114		9/16x18		
OP-122119		3/4x16		
OP-122122	1" x 14	7/8x14		
OP-122127		1" 1/16x12		
OP-122519		3/4x16		
OP-122522		7/8x14		
OP-122527	1" 3/16x12	1" 1/16x12		
OP-123019		3/4x16		
OP-123022		7/8x14		
OP-123027	1" 7/16x12	1" 1/16x12		
OP-123033		1" 5/16x12		
OP-123727	1" 7/16x12	1" 1/16x12		
OP-123733		1" 5/16x12		
OP-123741		1" 5/8x12		
OP-124233	1"11/16x12	1" 5/16x12		
OP-124241		1" 5/8x12		
OP-124247		1" 7/8x12		



ΠΑΞΙΜΑΔΙΑ



ΚΩΔΙΚΟΣ	O.R.F.S.	ΣΙΔ/ΝΑ	€	+ΦΠΑ
OP-000314	9\16	6		
OP-000317	11\16	8 10		
OP-000321	13\16	12		
OP-000325	1" x 14	14-15-16		
OP-000330	1" 3/16	18-20		
OP-000337	1" 7/16	22-25		
OP-000342	1"11/16	28-30-32		
OP-000350	2"	35-38		

ΜΠΙΜΠΙΚΙΑ O.R.F.S.

ΚΩΔΙΚΟΣ	O.R.F.S.	ΣΙΔ/ΝΑ	€	+ΦΠΑ
OP-000101	9\16	6		
OP-000102	11\16	10		
OP-000103	13\16	12		
OP-000104	1" x 14	16		
OP-000105	1" 3/16	20		
OP-000106	1" 7/16	25		
OP-000107	1"11/16	30		
OP-000108	2"	38		
OP-000109	11\16	8		
OP-000110	1" x 14	14		
OP-000111	1" x 14	15		
OP-000112	1" 3/16	18		
OP-000113	1" 7/16	22		
OP-000114	1"11/16	28		
OP-000115	1"11/16	32		
OP-000116	2"	35		



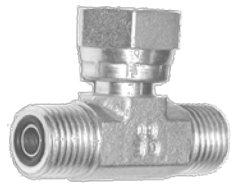
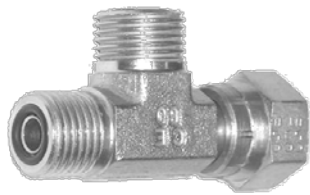
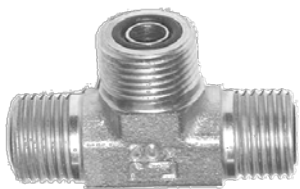

ΤΑΦ Α-Α-Α Ο.Ρ.Φ.Σ.				ΤΑΦ Α-Α-Θ Ο.Ρ.Φ.Σ.				ΤΑΦ Α-Θ-Α Ο.Ρ.Φ.Σ.			
ΚΩΔΙΚΟΣ	O.R.F.S.	€	+ΦΠΑ	ΚΩΔΙΚΟΣ	O.R.F.S.	€	+ΦΠΑ	ΚΩΔΙΚΟΣ	O.R.F.S.	€	+ΦΠΑ
OP-391414	9\16			OP-461414	9\16			OP-501414	9\16		
OP-391717	11\16			OP-461717	11\16			OP-501717	11\16		
OP-392121	13\16			OP-462121	13\16			OP-502121	13\16		
OP-392525	1" x 14			OP-462525	1" x 14			OP-502525	1" x 14		
OP-393030	1" 3/16			OP-463030	1" 3/16			OP-503030	1" 3/16		
OP-393737	1" 7/16			OP-463737	1" 7/16			OP-503737	1" 7/16		
OP-394242	1"11/16			OP-464242	1"11/16			OP-504242	1"11/16		
OP-395050	2" x 12			OP-465050	2" x 12			OP-505050	2" x 12		

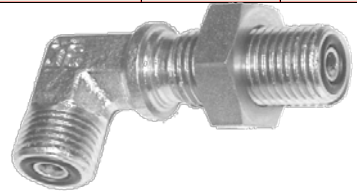

ΤΑΦ ΑΚΡΗ ΚΟΝΤΡΑ Ο.Ρ.Φ.Σ.				ΤΑΦ ΜΕΣΗ ΚΟΝΤΡΑ Ο.Ρ.Φ.Σ.				ΓΩΝΙΑ ΚΟΝΤΡΑ Ο.Ρ.Φ.Σ.			
ΚΩΔΙΚΟΣ	O.R.F.S.	€	+ΦΠΑ	ΚΩΔΙΚΟΣ	O.R.F.S.	€	+ΦΠΑ	ΚΩΔΙΚΟΣ	O.R.F.S.	€	+ΦΠΑ
OP-471414	9\16			OP-481414	9\16			OP-371414	9\16		
OP-471717	11\16			OP-481717	11\16			OP-371717	11\16		
OP-472121	13\16			OP-482121	13\16			OP-372121	13\16		
OP-472525	1" x 14			OP-482525	1" x 14			OP-372525	1" x 14		
OP-473030	1" 3/16			OP-483030	1" 3/16			OP-373030	1" 3/16		
OP-473737	1" 7/16			OP-483737	1" 7/16			OP-373737	1" 7/16		
OP-474242	1"11/16			OP-484242	1"11/16			OP-374242	1"11/16		

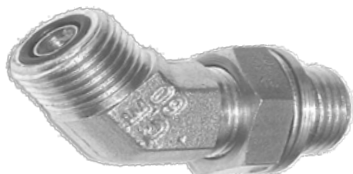

ΗΜΙΓΩΝΙΑ ΚΟΝΤΡΑ Ο.Ρ.Φ.Σ.				ΓΩΝΙΑ Α-Θ Ο.Ρ.Φ.Σ.				ΗΜΙΓΩΝΙΑ Α-Θ Ο.Ρ.Φ.Σ.			
ΚΩΔΙΚΟΣ	O.R.F.S.	€	+ΦΠΑ	ΚΩΔΙΚΟΣ	O.R.F.S.	€	+ΦΠΑ	ΚΩΔΙΚΟΣ	O.R.F.S.	€	+ΦΠΑ
OP-451414	9\16			OP-421414	9\16			OP-131414	9\16		
OP-451717	11\16			OP-421717	11\16			OP-131717	11\16		
OP-452121	13\16			OP-422121	13\16			OP-132121	13\16		
OP-452525	1" x 14			OP-422525	1" x 14			OP-132525	1" x 14		
OP-453030	1" 3/16			OP-423030	1" 3/16			OP-133030	1" 3/16		
OP-453737	1" 7/16			OP-423737	1" 7/16			OP-133737	1" 7/16		
OP-454242	1"11/16			OP-424242	1"11/16			OP-134242	1"11/16		



ΤΑΠΕΣ ΘΗΛΥΚΕΣ



ΤΑΠΕΣ ΑΡΣΕΝΙΚΕΣ



ΠΑΞΙΜΑΔΙΑ ΚΟΝΤΡΑ

ΚΩΔΙΚΟΣ	O.R.F.S.	€	+ΦΠΑ	ΚΩΔΙΚΟΣ	O.R.F.S.	€	+ΦΠΑ	ΚΩΔΙΚΟΣ	O.R.F.S.	€	+ΦΠΑ
OP-150014	9\16			OP-140014	9\16			OP-000014	9\16		
OP-150017	11\16			OP-140017	11\16			OP-000017	11\16		
OP-150021	13\16			OP-140021	13\16			OP-000021	13\16		
OP-150025	1" x 14			OP-140025	1" x 14			OP-000025	1" x 14		
OP-150030	1" 3/16			OP-140030	1" 3/16			OP-000030	1" 3/16		
OP-150037	1" 7/16			OP-140037	1" 7/16			OP-000037	1" 7/16		
OP-150042	1"11/16			OP-140042	1"11/16						
OP-150050	2" x 12			OP-140050	2" x 12						



ΚΥΑΘΙΑ FLEX ΑΛΟΥΜΙΝΙΟΥ

ΚΩΔΙΚΟΣ	ΔΙΑΣΤΑΣΗ	€	+ΦΠΑ
ΡΠ-310010	10X12		
ΡΠ-310011	11X13		
ΡΠ-310012	12x14		
ΡΠ-310013	13x15		
ΡΠ-310014	14x16		
ΡΠ-310015	15x17		
ΡΠ-310016	16x18		
ΡΠ-310018	18x20		
ΡΠ-310020	20x22		
ΡΠ-310022	22X24		
ΡΠ-310024	24x26		
ΡΠ-310026	26X28		
ΡΠ-310028	28x30		
ΡΠ-310030	30x32		
ΡΠ-310033	33x35		
ΡΠ-310038	38x40		
ΡΠ-310048	48X50		
ΡΠ-310051	50x52		
ΡΠ-310057	57x60		
ΡΠ-310060	60x62		
ΡΠ-310065	65X67		
ΡΠ-310076	76X78		

ΚΥΑΘΙΑ FLEX ΓΕΡΜΑΝΙΑΣ σιδερένια

ΡΠ-310Σ10	10,5mm		
ΡΠ-310Σ11	11,5mm		
ΡΠ-310Σ12	12,5mm		
ΡΠ-310Σ13	13,5mm		
ΡΠ-310Σ14	14,5mm		
ΡΠ-310Σ15	15,5mm		
ΡΠ-310Σ16	16mm		
ΡΠ-310Σ18	18mm		
ΡΠ-310Σ20	20mm		
ΡΠ-310Σ22	22mm		
ΡΠ-310Σ23	23mm		
ΡΠ-310Σ24	24,5mm		
ΡΠ-310Σ25	25,5mm		
ΡΠ-310Σ26	26,5mm		
ΡΠ-310Σ28	28mm		
ΡΠ-310Σ30	30,5mm		
ΡΠ-310Σ33	33mm		

ΑΡΣΕΝΙΚΑ ΚΟΜΦΛΕΡ ουρά πίεσεως

ΚΩΔΙΚΟΣ	ΔΙΑΣΤΑΣΗ	€	ΚΟΜΠΛΕ	+ΦΠΑ
ΡΦ-010003	22X1,5-1/2 ΙΣΙΑ			
ΡΦ-010008	22X1,5-1/2 16L			
ΡΦ-010028	26X1,5-1/2 ΙΣΙΑ			
ΡΦ-010009	22X1,5-5/8 ΙΣΙΑ			
ΡΦ-010007	26X1,5-5/8 ΙΣΙΑ			

ΘΗΛΥΚΑ ΚΟΜΦΛΕΡ ουρά πίεσεως

ΚΩΔΙΚΟΣ	ΔΙΑΣΤΑΣΗ	€	ΚΟΜΠΛΕ	+ΦΠΑ
ΡΦ-020007	22X1,5-1/2 ΙΣΙΑ			
ΡΦ-020009	26X1,5-1/2 ΙΣΙΑ			
ΡΦ-020014	22X1,5-5/8 ΙΣΙΑ			
ΡΦ-020008	26X1,5-5/8 ΙΣΙΑ			

ΑΡΣΕΝΙΚΑ Ν.Ρ.Τ. χειρόπρεσσας

ΚΩΔΙΚΟΣ	ΔΙΑΣΤΑΣΗ	€	+ΦΠΑ
PX-002610	1\4 - 3\8		
PX-002620	3\8 - 3\8		
PX-002621	3\8 - 1\2		
PX-002630	1\2 - 1\2		
PX-002631	3\4 - 5\8		
PX-002640	3\4 - 3\4		
PX-002641	1" - 3/4		
PX-002650	1" - 1"		

ΘΗΛΥΚΑ Β.Σ.Ρ. χειρόπρεσσας

PX-002730	1\8 - 1\4		
PX-002740	1\4 - 1\4		
PX-002741	1\4 - 5\16		
PX-002760	3\8 - 3\8		
PX-002770	1\2 - 1\2		
PX-002780	3\4 - 3\4		
PX-002782	3\4 - 5\8 I.E.		
PX-002783	3\4 - 3\4 I.E.		
PX-002781	1" - 3\4 I.E.		
PX-002790	1" - 1"		

ΘΗΛΥΚΑ ΜΕΤΡΙΚΑ χειρόπρεσσας

PX-002800	10X1-1/4		
PX-002810	12 X 1,5-1/4		
PX-002820	14 X 1,5-5/16		
PX-002830	16 X 1,5-3/8		

ΑΡΣΕΝΙΚΑ αεροφρένων χειρόπρεσσας

ΡΦ-010027	16X1,5 -3/8 ΙΣΙΑ		
ΡΦ-010000	16X1,5 -1/2 ΙΣΙΑ		
ΡΦ-010001	22X1,5-1/2 ΙΣΙΑ		
ΡΦ-010002	22X1,5-5/8 ΙΣΙΑ		
ΡΦ-010004	26X1,5-1/2 ΙΣΙΑ		
ΡΦ-010006	26X1,5-5/8 ΙΣΙΑ		

ΘΗΛΥΚΑ αεροφρένων χειρόπρεσσας

ΡΦ-020001	18X1,5 -3/8 12L		
ΡΦ-020002	18X1,5 -1/2 12L		
ΡΦ-020003	22X1,5 -1/2 I.E		
ΡΦ-020006	22X1,5 -5/8 I.E		
ΡΦ-020004	26X1,5 -1/2 I.E		
ΡΦ-020005	26X1,5 -5/8 I.E		

ΟΥΡΕΣ ΧΕΙΡΟΠΡΕΣΣΑΣ ΣΚΕΤΕΣ

ΡΦ-020016	1/8 & 10X1 -1/4		
ΡΦ-020018	12X1,5 -1/4		
ΡΦ-020019	1/4 & 14X1,5- 5/16		
ΡΦ-020023	3/8 & 16X1,5-3/8		
ΡΦ-020020	18X1,5-3/8		
ΡΦ-020021	18x1,5-1/2		
ΡΦ-020022	22x1,5-1/2 I.E		
ΡΦ-020027	22X,1,5-13/16-1/2		
ΡΦ-020025	22X1,5-5/8 I.E		
ΡΦ-020024	26X1,5-5/8 I.E		



ΘΗΛΙΕΣ FLEX			
PX-002961	6mm	3\16	
PX-002960	8mm	3\16	
PX-002966	8mm	1\4	
PX-002970	10mm	1\4	
PX-002975	10mm	5\16	
PX-002965	10mm	3\8	
PX-002979	12mm	5,5mm	
PX-002980	12mm	1\4	
PX-002981	12mm	5\16	
PX-002987	12mm	3\8	
PX-002988	14mm	5,5mm	
PX-002992	14mm	1\4	
PX-002991	14mm	5\16	
PX-003000	14mm	3\8	
PX-003011	16mm	3\8	
PX-003010	16mm	1\2	
PX-003021	18mm	3\8	
PX-003020	18mm	1\2	
PX-002993	1\2X20	3\8	



ΘΗΛΙΕΣ FLEX ΔΙΠΛΕΣ			
PX-002964	6mm	3\16	
PX-002962	8mm	3\16	
PX-002974	10mm	1\4	
PX-002985	12mm	5\16	
PX-003022	14mm	3\8	



ΘΗΛΙΕΣ ΠΟΛΥΑΜΙΔΙΟΥ			
PX-002967	6mm	6x4	
PX-002963	8mm	6x4	
PX-002971	10mm	6X4	
PX-002972	10mm	8X6	
PX-002986	12mm	6x4	
PX-002982	12mm	8X6	
PX-002983	12mm	10X8	
PX-002984	14mm	6X4	
PX-003001	14mm	8X6	
PX-003002	14mm	10X8	
PX-003003	14mm	12X9	
PX-003014	16mm	6X4	
PX-003013	16mm	8X6	
PX-003012	16mm	10X8	
PX-003004	16mm	12X9	
PX-003015	18mm	15X12	

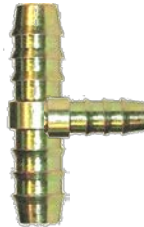

ΘΗΛΙΕΣ ΜΕ ΣΠΕΙΡΩΜΑ 60°

PX-003005	ΘΗΛΙΑ 10-12X1,5		
PX-003006	ΘΗΛΙΑ 12-14X1,5		
PX-003007	ΘΗΛΙΑ 14-16X1,5		
PX-003008	ΘΗΛΙΑ 16-18X1,5		
PX-003009	ΘΗΛΙΑ 18-22X1,5		

ΟΥΡΕΣ ΣΥΝΔΕΣΜΟΙ ΠΟΛΥΑΜΙΔΙΟΥ

PΦ-140030	6X4		
PΦ-140031	8X6		
PΦ-140032	10X8		
PΦ-140034	12X9		
PΦ-140035	15X12		
PΦ-140036	16X12		

ΤΑΦ ΟΥΡΑ ΣΥΝΔΕΣΜΟΣ ΠΟΛΥΑΜΙΔΙΟΥ

PΦ-140040	6X4		
PΦ-140041	8X6		
PΦ-140042	10X8		
PΦ-140043	12X9		

ΑΝΤΙΣΤΑΣΕΙΣ ΠΛΑΣΤΙΚΟΣΩΛΗΝΩΝ

ΚΩΔΙΚΟΣ	ΔΙΑΣΤΑΣΗ- ΣΩΛΗΝΑ	€	+ΦΠΑ
PΦ-080001	2mm (4X2)		
PΦ-080015	3mm (5X3-6X3)		
PΦ-080002	4mm (6X4)		
PΦ-080016	5mm (7X5)		
PΦ-080003	6mm (8X6)		
PΦ-080013	7mm (10X7-3/8)		
PΦ-080004	7,5mm(10X7,5)		
PΦ-080005	8mm(10X8-11X8)		
PΦ-080006	9mm (12X9)		
PΦ-080007	10mm (14X10)		
PΦ-080008	11mm (16X11)		
PΦ-080009	12mm (15X12-16X12)		
PΦ-080014	14mm (18X14)		
PΦ-080010	4,3mm (1/4)		
PΦ-080011	6,2mm (3/8)		
PΦ-080012	9,5mm (1/2)		

ΜΠΙΜΠΙΚΙΑ ΟΡΕΙΧ/ΝΑ

PΦ-090001	1\8		
PΦ-090002	3\16		
PΦ-090003	1\4		
PΦ-090004	5\16		
PΦ-090005	3\8		
PΦ-090006	7\16		
PΦ-090007	1\2		
PΦ-090008	4mm		
PΦ-090025	5mm		
PΦ-090009	6mm		
PΦ-090010	8mm		
PΦ-090011	10mm		
PΦ-090012	12mm		
PΦ-090013	16mm		
PΦ-090024	7 L		
PΦ-090014	9 L		
PΦ-090000	11 L		
PΦ-090027	13 L		

ΡΑΚΟΡ VOLVO - SCANIA

ΑΡΣΕΝΙΚΑ



ΚΩΔΙΚΟΣ	ΔΙΑΣΤΑΣΗ	€	+ΦΠΑ
PΦ-030002	17/32-3/8		
PΦ-030005	11/16-3/8		
PΦ-030008	11/16-1/2		
PΦ-030011	13/16-1/2		

ΑΡΣΕΝΙΚΑ ΚΟΝΤΡΑ



ΚΩΔΙΚΟΣ	ΔΙΑΣΤΑΣΗ	€	+ΦΠΑ
PΦ-030000	7/16X24-1/4		
PΦ-030001	17/32-3/8		
PΦ-030004	11/16-3/8		
PΦ-030007	11/16-1/2		
PΦ-030010	13/16-1/2		

ΘΗΛΥΚΑ



ΚΩΔΙΚΟΣ	ΔΙΑΣΤΑΣΗ	€	+ΦΠΑ
PΦ-030013	7/16X24-1/4		
PΦ-030003	17/32-3/8		
PΦ-030006	11/16-3/8		
PΦ-030009	11/16-1/2		
PΦ-030012	13/16-1/2		



RZ ΧΕΙΡ/ΣΑΣ ΙΣΙΑ

PX-180405	4 mm -3/16		
PX-180505	5 mm -3/16		
PX-180606	6 mm -1/4		



RZ ΧΕΙΡ/ΣΑΣ ΓΩΝΙΕΣ

PX-190405	4 mm -3/16		
PX-190505	5 mm -3/16		
PX-190606	6 mm -1/4		



ΠΑΞΙΜΑΔΙΑ VOLVO-SCANIA

PΦ-090015	5/16X24	(1/8)		
PΦ-090016	3/8X24	(3/16)		
PΦ-090017	7/16X24	(1/4)		
PΦ-090018	1/2X24	(5/16)		
PΦ-090019	17/32	(3/8)		
PΦ-090021	11/16	(1/2)		
PΦ-090023	13/16	(5/8)		

ΣΥΝΔΕΣΜΟΙ VOLVO-SCANIA

ΚΩΔΙΚΟΣ	ΠΕΡΙΓΡΑΦΗ	€	+ΦΠΑ
PΦ-140001	1\8		
PΦ-140002	3\16		
PΦ-140003	1\4		
PΦ-140004	3\8		
PΦ-140005	1\2		
PΦ-140006	5\8		

ΜΑΣΤΟΙ VOLVO-SCANIA

PΦ-030015	1/8-5/16X24	(1/8)		
PΦ-030016	1/8-3/8X24	(3/16)		
PΦ-030017	1/8-7/16X24	(1/4)		
PΦ-030026	1/4-7/16X24	(1/4)		
PΦ-030018	1/4-17/32	(3/8)		
PΦ-030019	1/4-11/116	(1/2)		
PΦ-030020	3/8-11/16	(1/2)		
PΦ-030021	3/8-13/16	(5/8)		
PΦ-030022	1/2-13/16	(5/8)		
PΦ-030031	16X1,5-17/32	(3/8)		
PΦ-030024	16X1,5-11/16	(1/2)		
PΦ-030025	16X1,5-13/16	(5/8)		

ΜΑΣΤΟΙ για TURBO

PΦ-030023	6L -7/16X24 TURBO		
PΦ-030029	6L -7/16X24 1,5mm		
PΦ-030028	7\16x20-7/16X24		

ΡΑΚΟΡ ΑΥΤΟΛΙΠΑΝΣΗΣ ΣΥΣΤΟΛΗ ΑΡΣΕΝΙΚΟ ΘΗΛΥΚΟ

ΚΩΔΙΚΟΣ	ΑΡΣΕΝ.-ΘΗΛΥΚΟ	€	+ΦΠΑ
PΦ-100039	6X1 8X1		
PΦ-100040	8X1 8X1		
PΦ-100041	10X1 8X1		
PΦ-100044	8X1 10X1		
PΦ-100046	10X1 10X1		

ΓΩΝΙΑ ΑΡΣΕΝΙΚΟ ΘΗΛΥΚΟ

ΚΩΔΙΚΟΣ	ΑΡΣΕΝ.-ΘΗΛΥΚΟ	€	+ΦΠΑ
PΦ-100045	6X1 8X1		
PΦ-100042	8X1 8X1		
PΦ-100043	10X1 8X1		



ΜΟΥΦΕΣ ΑΜΕΡΙΚΗΣ αεροφρένων

ΚΩΔΙΚΟΣ	ΑΡΣΕΝ.-ΘΗΛΥΚΟ	€	+ΦΠΑ
PΦ-110001	22X1,5-1/4		
PΦ-110002	22X1,5-16X1,5		
PΦ-110003	22X1,5-3/8		
PΦ-110007	22X1,5-14X1,5		
PΦ-110008	22X1,5-18X1,5		
PΦ-110006	26X1,5-1/2		



ΜΟΥΦΕΣ ΑΓΓΛΙΑΣ

αεροφρένων

ΚΩΔΙΚΟΣ	ΑΡΣΕΝ.-ΘΗΛΥΚΟ	€	+ΦΠΑ
PΣ-071203	12X1,5-1/8		
PΦ-120002	1/4-22X1,5		
PΦ-120012	3/8-18X1,5		
PΦ-120003	3/8-22X1,5		
PΦ-120014	1/2-18X1,5		
PΦ-120004	1/2-22X1,5		
PΦ-120007	16X1,5-1/4		
PΦ-120001	16x1,5-22x1,5		
PΦ-120011	18X1,5-1/4		
PΦ-120005	22X1,5-1/2		
PΦ-120009	22X1,5 A-Θ VOSS		
PΦ-120010	A16-Θ22X1,5 VOSS		
PΦ-120008	16X1,5 A-Θ VOSS		
PΦ-120006	A22X1,5 Θ16 VOSS		



ΣΥΝΔΕΣΜΟΙ ΚΟΝΤΡΑ αεροφρένων

ΚΩΔΙΚΟΣ	ΒΑΣΗ -ΚΟΝΤΡΑ	€	+ΦΠΑ
PΦ-010019	22X1,5-10L		
PΦ-010013	22X1,5-12L		
PΦ-010014	22X1,5-15L		
PΦ-010015	22X1,5-22X1,5		
PΦ-010016	16X1,5-12L		
PΦ-010017	16X1,5-22X1,5		
PΦ-010018	18X1,5-22X1,5		
PΦ-010020	18X1,5-10L		



ΡΟΖΕΤΕΣ 16X1,5

Για αναμονές βαλβίδων υπουργείου

PA-016411	16X,15-1/4		
PA-016414	16X,15-5/16		



ΠΕΤΑΛΟΥΔΕΣ 16X1,5

PA-016412	ΠΕΤΑΛΟΥΔΑ 16X1,5-1/4		
PA-016413	ΛΑΣΤΙΧΑ		

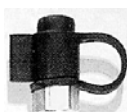

ΑΝΑΜΟΝΕΣ βαλβίδες Υπουργείου

PΦ-130020	ΘΗΛΥΚΟ 12X1,5		
-----------	---------------	--	--



ΠΑΞΙΜΑΔΙΑ ΤΥΠΟΣ LL ΑΕΡΟΦΡΕΝΩΝ

PΦ-020040	5 LL (10X1)		
PΦ-020041	10LL (14X1)		
PΦ-020042	12LL (14X1)		
PΦ-020043	16 LL (22X1,5)		

ΜΠΙΜΠΙΚΙΑ ΤΥΠΟΣ LL ΑΕΡΟΦΡΕΝΩΝ

PΦ-020050	5 LL		
PΦ-020051	10LL		
PΦ-020052	12LL		
PΦ-020053	16 LL		

ΣΥΝΔΕΣΜΟΙ ΑΕΡΟΦΡΕΝΩΝ

PΦ-140015	5mm		
PΦ-140013	7mm		
PΦ-140007	9mm		
PΦ-140008	11mm		
PΦ-140014	13mm		
PΦ-140016	16L (22X1,5)		
PΦ-140009	8-9mm		
PΦ-140010	10-11mm		
PΦ-140011	12-11mm		
PΦ-140012	14-12mm		

ΠΑΞΙΜΑΔΙΑ ΜΑΚΡΥΑ

ΚΩΔΙΚΟΣ	ΔΙΑΣΤΑΣΗ	€	+ΦΠΑ
PΦ-020010	22X1,5		
PΦ-020011	26X1,5		

ΚΑΠΕΛΑΚΙΑ ΦΡΕΝΩΝ

PΦ-020012	L15		
PΦ-020013	L18		

ΜΑΣΤΟΙ ΙΣΙΑ ΕΔΡΑ

PΦ-010010	22X1,5-22X1,5		
PΦ-010011	26X,15-26X1,5		
PΦ-010012	22X1,5-26X1,5		

ΣΥΝΔΕΣΜΟΣ ΚΟΝΤΡΑ 8L ΘΗΛ.1/4 (ΜΑΝΟΜΕΤΡΟ)

PΦ-100030	ΚΟΝΤΡΑ 8L-ΘΗΛ. 1/4		
-----------	--------------------	--	--

ΤΑΦ ΑΝΑΜΟΝΩΝ

PΦ-130001	16X1,5-ANAM-10L		
PΦ-130002	16X1,5-ANAM-12L		
PΦ-130003	16X1,5-ANAM-11\16		
PΦ-130004	22X1,5-ANAM-12L		
PΦ-130005	22X1,5-ANAM-22X1,5		
PΦ-130006	18X1,5-ANAM-18X1,5		
PΦ-130007	18X1,5-ANAM-12L τρελό		
PΦ-130008	16X1,5-10L-ANAMONH		
PΦ-130009	16X1,5-12L-ANAM		
PΦ-130010	16X1,5-11\16-ANAM		
PΦ-130011	22X1,5-12L-ANAM		
PΦ-130012	22X1,5-22X1,5-ANAM		
PΦ-130013	16X1,5-ANAM-17\32		

ΕΞΑΕΡΩΤΗΡΑΣ 22X1,5

PΦ-130024	Εξαερωτήρας 22x1,5		
-----------	--------------------	--	--



ΣΠΙΡΑΛ ΜΕ ΑΚΡΑ 16X1,5 ΕΛΑΤΗΡΙΟ 12X9

ΠΟΙΟΤΗΤΑ RILSAN ΡΑ 12 ΔΙΑΜΕΤΡΟΣ 96mm 21 ΣΠΕΙΡΕΣ

ΚΩΔΙΚΟΣ	ΠΕΡΙΓΡΑΦΗ	€	+ΦΠΑ
ΡΑ-013405	SPIRAL 12X9 A-A 16X1.5		

Σε χρώματα κόκκινο και κίτρινο.



ΣΠΙΡΑΛ ΝΤΑΛΙΚΑΣ ΡΑ 12 18 σπείρες χωρίς άκρα

ΚΩΔΙΚΟΣ	ΠΕΡΙΓΡΑΦΗ	€	+ΦΠΑ
ΡΑ-013406	SPIRAL 12X9 ΧΩΡΙΣ ΑΚΡΑ		

Σε χρώματα μαύρο και κίτρινο.



ΧΟΥΦΤΕΣ ΝΤΑΛΙΚΑΣ

ΚΩΔΙΚΟΣ	ΠΕΡΙΓΡΑΦΗ	€	+ΦΠΑ
ΡΑ-013420	ΧΟΥΦΤΕΣ 22X1,5 ΑΠΛΕΣ		
ΡΑ-013421	ΧΟΥΦΤΕΣ 22X1,5 ΑΥΤΟΜΑΤΕΣ		
ΡΑ-013422	ΛΑΣΤΙΧΑ ΓΙΑ ΧΟΥΦΤΕΣ		



ΠΡΟΕΚΤΑΣΕΙΣ L90 ΓΙΑ ΧΟΥΦΤΕΣ ΝΤΑΛΙΚΑΣ

ΚΩΔΙΚΟΣ	ΠΕΡΙΓΡΑΦΗ	€	+ΦΠΑ
ΡΣ-048016	ΑΡΣ-ΘΗΛΥΚΟ 16X1,5 L90		

SPIRAL HTR 5μέτρων με πιστόλι-(αλλη ακρη σκέτη)

ΚΩΔΙΚΟΣ	ΠΕΡΙΓΡΑΦΗ	€	+ΦΠΑ
ΠΠ-000023	6X4 HTR L5 ίσιες άκρες &πιστόλι		
ΠΠ-000024	8X6 HTR L5 ίσιες άκρες &πιστόλι		



Σε χρώματα πορτοκαλί, μπλε και μαύρο.

SPIRAL P.U. 5μέτρων με πιστόλι (αλλη ακρη σκέτη)

ΚΩΔΙΚΟΣ	ΠΕΡΙΓΡΑΦΗ	€	+ΦΠΑ
ΠΠ-000039	6x4 P.U L5 ίσιες άκρες &πιστόλι		

Σε χρώματα κίτρινο, μπλε και μαύρο.

ΣΩΛΗΝΑ ΑΕΡΟΣ 6MM ΜΕ ΡΟΖΕΤΑ & ΑΕΡΟΜΕΤΡΟ

ΚΩΔΙΚΟΣ	ΠΕΡΙΓΡΑΦΗ	€	+ΦΠΑ
ΠΠ-000051	20 bar 6mm 10μ. Ροζέτα-αερόμετρο		
ΠΠ-000052	20 bar 6mm 12μ. Ροζέτα-αερόμετρο		
ΠΠ-000053	20 bar 6mm 15μ. Ροζέτα-αερόμετρο		
ΠΠ-000054	20 bar 6mm 10μ. Ροζέτα-μανταλάκι		
ΠΠ-000055	20 bar 6mm 12μ. Ροζέτα-μανταλάκι		
ΠΠ-000056	20 bar 6mm 15μ. Ροζέτα-μανταλάκι		



ΦΡΕΝΩΝ ΓΙΑ 3/16 R1T



ΑΡΣΕΝΙΚΑ ΜΕ ΕΔΡΑ- ΒΙΖΟΥΛΟ				ΑΡΣΕΝΙΚΑ ΚΟΝΤΡΑ			
PΦ-004000	ΑΡΣ.10X1 ΕΔΡΑ			PΦ-004020	ΑΡΣ.10X1 ΚΟΝΤΡΑ		
PΦ-004010	ΑΡΣ.10X1 ΡΟΔΕΛΑ			PΦ-004051	ΑΡΣ.12X1 ΚΟΝΤΡΑ		
PΦ-004001	ΑΡΣ.10X1 ΒΙΖΟΥΛΟ			PΦ-004052	ΑΡΣ.12X1,25 ΚΟΝΤΡΑ ΒΙΖΟΥΛΟ		
PΦ-004040	ΑΡΣ.10X1,25 ΕΔΡΑ			PΦ-004110	ΑΡΣ.3/8X24 ΚΟΝΤΡΑ		
PΦ-004050	ΑΡΣ.12X1 ΕΔΡΑ			PΦ-004121	ΑΡΣ.7/16X20 ΚΟΝΤΡΑ		
PΦ-004295	ΑΡΣ.12X1,25 ΕΔΡΑ			PΦ-004150	ΑΡΣ.1/2X20 ΚΟΝΤΡΑ		
PΦ-004053	ΑΡΣ.12X1,5 ΡΟΔΕΛΑ						
PΦ-004296	ΑΡΣ.12X1,5 ΕΔΡΑ			PΦ-004071	A.16X1,5-Θ10X1 ΒΙΖΟΥΛΟ		
PΦ-004297	ΑΡΣ.14X1 ΕΔΡΑ			PΦ-004072	A.16X1,5-Θ10X1,25 ΒΙΖΟΥΛΟ		
PΦ-004070	ΑΡΣ.14X1,5 ΕΔΡΑ			PΦ-004080	A.16X1,5-Θ.12X1 ΒΙΖΟΥΛΟ		
PΦ-004100	ΑΡΣ.3/8X24 ΡΟΔΕΛΑ			PΦ-004090	A.16X1,5-Θ.8X1,25 ΙΣΙΟ		
PΦ-004101	ΑΡΣ.3/8X24 ΒΙΖΟΥΛΟ			PΦ-004091	A. 20X1,5-Θ12X1 ΦΡΕΖΑ		
PΦ-004120	ΑΡΣ.7/16X20 ΕΔΡΑ			PΦ-004160	A.5/8X18-Θ.7/16X24 ΒΙΖΟΥΛΟ		
PΦ-004122	ΑΡΣ.7/16X20 ΡΟΔΕΛΑ			PΦ-004170	A.5/8X26-Θ.3/8X24 ΦΡΕΖΑ		
PΦ-004130	ΑΡΣ.1/2X20 ΕΔΡΑ			PΦ-004180	A.5/8X18-Θ.3/8X24 ΒΙΖΟΥΛΟ		
PΦ-004140	ΑΡΣ.1/2X20 ΡΟΔΕΛΑ						
PΦ-004053	ΑΡΣ.11/16X16 ΡΟΔΕΛΑ						



ΘΗΛΥΚΑ ΒΙΖΟΥΛΟ				ΘΗΛΥΚΑ ΜΕ ΦΡΕΖΑ			
PΦ-004210	ΘΗΛ.10X1 ΒΙΖΟΥΛΟ			PΦ-004200	ΘΗΛ.10X1 ΦΡΕΖΑ		
PΦ-004211	ΘΗΛ.10X1 ΣΧΙΣΤΑ ΒΙΖΟΥΛΟ			PΦ-004220	ΘΗΛ.10X1,25 ΦΡΕΖΑ		
PΦ-004212	ΘΗΛ.10X1 ΒΙΖΟΥΛΟ ΗΙΝΟ			PΦ-004240	ΘΗΛ.10X1 ΑΣΦΑΛΕΙΑ ΦΡΕΖΑ		
PΦ-004241	ΘΗΛ.10X1 ΒΙΖ. ΔΙΠΛΗ ΑΣΦΑΛΕΙΑ			PΦ-004251	ΘΗΛ.12X1 ΦΡΕΖΑ		
PΦ-004230	ΘΗΛ.10X1,25 ΒΙΖΟΥΛΟ			PΦ-004300	ΘΗΛ. 12X1,25 ΦΡΕΖΑ		
PΦ-004250	ΘΗΛ.12X1 ΒΙΖΟΥΛΟ			PΦ-004270	ΘΗΛ.3/8X24 ΦΡΕΖΑ		
PΦ-004299	ΘΗΛ. 12X1,25 ΒΙΖΟΥΛΟ						
PΦ-004298	ΘΗΛ. 12X1,5 ΒΙΖΟΥΛΟ						
PΦ-004280	ΘΗΛ.14X1 ΒΙΖΟΥΛΟ						
PΦ-004290	ΘΗΛ.14X1,5 ΒΙΖΟΥΛΟ						
PΦ-004260	ΘΗΛ.3/8X24 ΒΙΖΟΥΛΟ						



ΘΗΛΙΕΣ ΛΟΞΕΣ

PΦ-004291	ΘΗΛΙΑ ΛΟΞΗ FIAT Φ10		
PΦ-004281	ΘΗΛΙΑ ΛΟΞΗ Φ12		
PΦ-004294	ΘΗΛΙΑ OPEL		



ΑΡΣΕΝΙΚΑ ΣΙΔΗΡΟΣΩΛΗΝΑΣ				ΤΑΠΕΣ ΦΡΕΝΩΝ			
PΦ-070000	8X1-4mm			PΦ-070015	10X1		
PΦ-070001	10X1-3\16			PΦ-070016	10X1,25		
PΦ-070002	10X1,25-3\16			PΦ-070017	12X1		
PΦ-070003	12X1-3\16			PΦ-070018	3\8X24		
PΦ-070004	12X1-1\4						
PΦ-070005	12X1,25-1\4						
PΦ-070006	14X1-5\16						
PΦ-070007	14X1,5-5\16						
PΦ-070008	3\8X24-3\16			PΦ-004500	ΒΙΣΜΑ ACTROS -ΑΡΣ. 1/4		
PΦ-070009	7\16X24-1\4			PΦ-004501	ΒΙΣΜΑ ACTROS -1/4 ουρά		
PΦ-070010	1\2X20-1\4						
PΦ-070011	1\2X20-5\16						
PΦ-070019	9\16X18-5\16						
PΦ-070020	9\16X24-5\16						
PΦ-070012	5\8X18-3\8						



ΑΡΣΕΝΙΚΟ 12X1 ΖΕΤΟΡ ΜΑΚΡΥ				ΑΡΣΕΝΙΚΑ ΦΡΕΝΩΝ 3/16 R1T			
PΦ-070023	zetur 12x1 Μακρύ			ΡΠ-151200	ΑΡΣ 12X1 ΒΙΖ.-3/16 ΚΟΝΤΟ		
				ΡΠ-151201	ΑΡΣ 12X1 ΒΙΖ.-3/16 ΚΟΝΤΡΑ		



ΦΡΕΝΩΝ ΠΡΕΣΣΑΡΙΣΤΑ ΓΙΑ 1/8 TEFLON



ΑΡΣΕΝΙΚΑ ΜΕ ΕΔΡΑ

ΘΗΛΥΚΑ ΒΙΖΟΥΛΟ

ΚΩΔΙΚΟΣ	ΠΕΡΙΓΡΑΦΗ	ΣΚΕΤΑ	ΚΟΜΠΛΕ	+ΦΠΑ	ΚΩΔΙΚΟΣ	ΠΕΡΙΓΡΑΦΗ	ΣΚΕΤΑ	ΚΟΜΠΛΕ	+ΦΠΑ
ΡΦ-271000	ΑΡΣ.10X1 ΕΔΡΑ				ΡΦ-281006	ΘΗΛ. 10X1 ΒΙΖ. ΑΣΦΑΛΕΙΑ			
ΡΦ-271001	ΑΡΣ.10X1 ΒΙΖΟΥΛΟ				ΡΦ-280001	ΘΗΛ. 10X1 ΤΡΕΛΛΟ ΒΙΖΟΥΛΟ			
ΡΦ-271006	ΑΡΣ.10X1,25 ΕΔΡΑ				ΡΦ-281007	ΘΗΛ. 10X1,25 ΒΙΖ. ΑΣΦΑΛΕΙΑ			
ΡΦ-271004	ΑΡΣ. 12X1 ΕΔΡΑ				ΡΦ-281001	ΘΗΛ. 12X1 ΒΙΖ. ΑΣΦΑΛΕΙΑ			
ΡΦ-271009	ΑΡΣ.3/8X24 ΕΔΡΑ				ΡΦ-281009	ΘΗΛ. 3/8X24 ΒΙΖ. ΑΣΦΑΛΕΙΑ			
ΡΦ-271002	ΑΡΣ.10X1 ΚΟΝΤΡΑ				ΘΗΛΥΚΑ ΜΕ ΦΡΕΖΑ				
ΡΦ-271008	ΑΡΣ.16X1.5-10X1.25 ΒΙΖΟΥΛΟ				ΡΦ-280002	ΘΗΛ. 10X1 ΤΡΕΛΛΟ Φ14 ΦΡΕΖΑ			
ΡΦ-281004	ΑΡΣ.5/8X26-3/8X24				ΡΦ-281002	ΘΗΛ. 10X1 ΦΡΕΖΑ ΣΤΑΘΕΡΟ			
ΡΦ-271010	ΑΡΣ.3/8X24 ΚΟΝΤΡΑ				ΡΦ-281000	ΘΗΛ. 10X1 ΤΡΕΛΛΟ ΦΡΕΖΑ ΑΣΦ.			
ΡΦ-281004	ΑΡΣ.5/8X26-3/8X24				ΡΦ-281012	ΘΗΛ.10X1 ΦΡΕΖΑ ΑΣΦΑΛΕΙΑ			
ΡΦ-271011	ΑΡΣ.12X1,25 ΚΟΝΤΡΑ				ΡΦ-281008	ΘΗΛ.10X1,25 ΦΡΕΖΑ ΑΣΦΑΛΕΙΑ			
					ΡΦ-281010	ΘΗΛ.3/8X24 ΦΡΕΖΑ ΑΣΦΑΛΕΙΑ			
					ΡΦ-281011	ΘΗΛ.12X1,25 ΦΡΕΖΑ ΤΡΕΛΛΟ			



ΘΗΛΙΕΣ ΙΣΙΕΣ & ΓΩΝΙΕΣ

ΑΡΣΕΝΙΚΑ ΤΡΕΛΛΑ ΙΣΙΑ- ΓΩΝΙΕΣ

ΡΦ-270803	Φ8 ΙΣΙΑ μακρυνά κολλητή				ΡΦ-271007	ΑΡΣ.10X1 ΤΡΕΛΟ ΒΙΖΟΥΛΟ			
ΡΦ-271003	Φ10 ΙΣΙΑ μονοκόματη				ΡΦ-271005	ΑΡΣ.10X1 ΤΡΕΛΟ ΦΡΕΖΑ			
ΡΦ-281203	Φ12 ΙΣΙΑ				ΡΦ-280004	ΑΡΣ.10X1 ΤΡΕΛΟ 45° ΒΙΖΟΥΛΟ			
ΡΦ-280003	Φ10 ΙΣΙΑ μακρυνά κολλητή				ΡΦ-280005	ΑΡΣ.10X1 ΤΡΕΛΟ 90° ΒΙΖΟΥΛΟ			
ΡΦ-290005	Φ10 ΙΣΙΑ μακρυνά μονοκόματη				ΡΦ-280006	ΑΡΣ.10X1 ΤΡΕΛΟ 45° ΦΡΕΖΑ			
ΡΦ-290004	Φ12 ΙΣΙΑ μακρυνά κολλητή				ΡΦ-280007	ΑΡΣ.10X1 ΤΡΕΛΟ 90° ΦΡΕΖΑ			
ΡΦ-281003	Φ10 45° κολλητή				ΡΦ-271012	ΑΡΣ.3/8X24 ΤΡΕΛΟ ΒΙΖΟΥΛΟ			
ΡΦ-291003	Φ10 90° κολλητή				ΡΦ-271013	ΑΡΣ.3/8X24 ΤΡΕΛΟ ΦΡΕΖΑ			
ΡΦ-281005	Φ10 30° μονοκόματη				ΣΩΛΗΝ ΤΕΦΛΟΝ ΜΕ ΚΑΛΥΜΑ				
ΡΦ-290001	Φ10 45° μονοκόματη								
ΡΦ-290002	Φ10 90° μονοκόματη								

ΔΙΑΦΟΡΑ ΡΑΚΟΡ ΓΙΑ 1/8 ΣΩΛΗΝΑ

ΡΠ-100303	ΘΗΛΥΚΑ 1/8-1/8				<p>Σωλήν teflon 1/8 AISI 304 Stainless steel με κάλυμα από PA 11, σε διάφορα χρώματα. Β.Ρ 827bar</p>				
ΡΠ-110303	ΓΩΝΙΕΣ 1/8-1/8								
ΡΠ-180403	RZ 4LL-1/8								
ΡΠ-180603	RZ 6L-S-1/8								
ΡΠ-161203	ΘΗΛΥΚΑ 6L-1/8								
ΡΠ-160603	ΘΗΛΥΚΑ 6S-1/8								
ΡΠ-171203	ΓΩΝΙΕΣ 6L-1/8								
ΡΠ-170603	ΓΩΝΙΕΣ 6S-1/8								
ΚΤ-310003	ΚΥΑΘΙΟ ΤΕΦΛΟΝ 1/8				ΣΒ-18ΔΙ03	teflon 1/8 ΔΙΑΦΑΝΕΣ			
ΡΠ-317003	ΚΥΑΘΙΟ OL5-R7-R8 1/8				ΣΒ-18ΚΟ03	teflon 1/8 ΚΟΚΚΙΝΟ			
					ΣΒ-18ΜΑ03	teflon 1/8 ΜΑΥΡΟ			
					ΣΒ-18ΚΙ03	teflon 1/8 ΚΙΤΡΙΝΟ			
					ΣΒ-18ΜΠ03	teflon 1/8 ΜΠΛΕ			
					ΣΒ-18ΠΡ03	teflon 1/8 ΠΡΑΣΙΝΟ			
					ΣΒ-18ΠΟ03	teflon 1/8 ΠΟΡΤΟΚΑΛΙ			

ΡΑΚΟΡ ΚΑΜΠΙΝΑΣ ΦΟΡΤΗΓΩΝ ΓΙΑ 1/8 OL5-R8 ΣΩΛΗΝΑ

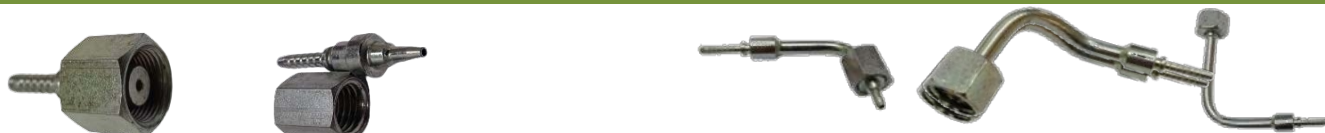

ΚΩΔΙΚΟΣ	ΔΙΑΣΤΑΣΗ	€	ΚΟΜΠΛΕ	+ΦΠΑ	ΚΩΔΙΚΟΣ	ΔΙΑΣΤΑΣΗ	€	ΚΟΜΠΛΕ	+ΦΠΑ
ΚΑ-000010	ΘΗΛΥΚΟ 12X1.5-1/8 D 3.3 VOLVO				ΚΑ-000000	ΓΩΝ.12X1,5-1/8 6L ΣΠΑΣΤΗ			
ΚΑ-000011	ΘΗΛΥΚΟ 12X1.5-1/8 6L TPS				ΚΑ-000001	ΓΩΝ.14X1,5-1/8 6S ΣΠΑΣΤΗ SCANIA			
ΚΑ-000012	ΘΗΛΥΚΟ 12X1-1/8 6L TPS				ΚΑ-000002	ΓΩΝΙΑ 12X1-1/8 VOLVO D3.3			
ΚΑ-000013	ΘΗΛΥΚΟ14X1.5-1/8 6S TPS				ΚΑ-000003	ΓΩΝΙΑ14X1,5-1/8 6S L70SCANIA			
					ΚΑ-000004	ΓΩΝΙΑ 12X1.5-1/8 VOLVO D 3.3			
					ΚΑ-000005	ΓΩΝΙΑ12X1.5-1/8 6L TPS			
					ΚΑ-000006	ΓΩΝΙΑ 12X1-1/8 6LL TPS			
					ΚΑ-000007	ΓΩΝΙΑ14X1.5-1/8 6S TPS			

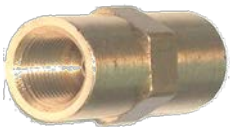

ΜΟΥΦΕΣ ΦΡΕΝΩΝ ΘΗΛΥΚΕΣ

ΚΩΔΙΚΟΣ	ΔΙΑΣΤΑΣΗ	€	+ΦΠΑ
PΦ-060001	10X1 ΒΙΖΟΥΛΟ		
PΦ-060002	10X1 ΦΡΕΖΑ		
PΦ-060003	10X1,25ΦΡΕΖΑ		
PΦ-060006	10X1,25 ΒΙΖΟΥΛΟ		
PΦ-060004	12X1 ΒΙΖΟΥΛΟ		
PΦ-060017	12X1 ΦΡΕΖΑ		
PΦ-060008	14X1 ΒΙΖΟΥΛΟ		
PΦ-060009	14X1,5 ΒΙΖΟΥΛΟ		
PΦ-060005	3\8X24 ΦΡΕΖΑ		
PΦ-060007	3\8X24 ΒΙΖΟΥΛΟ		
PΦ-060020	7\16X24 ΒΙΖΟΥΛΟ		
PΦ-060021	1\2X20 ΒΙΖΟΥΛΟ		



ΣΥΣΤΟΛΕΣ ΦΡΕΝΩΝ

ΚΩΔΙΚΟΣ	ΑΡΣΕΝ.-ΘΗΛΥΚΟ	€	+ΦΠΑ
PΦ-060010	A 10X1-Θ 10X1		
PΦ-060011	A 10X1-Θ 12X1		
PΦ-060012	A 12X1-Θ 12X1		
PΦ-060013	A 12X1-Θ 10X1		
PΦ-060014	A 14X1,5-Θ 12X1		
PΦ-060015	A 12X1-Θ 14X1,5		
PΦ-060016	A 12X1-Θ 14X1		

ΤΑΦ ΦΡΕΝΩΝ

PΦ-050001	10X1 ΒΙΖ.		
PΦ-050002	10X1ΦΡΕΖΑ		
PΦ-050003	10X1,25ΦΡΕΖ		
PΦ-050006	10X1,25 ΒΙΖ		
PΦ-050004	12X1 ΒΙΖ		
PΦ-050009	12X1ΦΡΕΖΑ		
PΦ-050005	3\8X24ΦΡΕΖ		
PΦ-050007	3\8X24ΒΙΖ		



ΣΤΑΥΡΟΙ

PΦ-040001	10X1 ΒΙΖ.		
PΦ-040002	10X1ΦΡΕΖΑ		
PΦ-040003	10X1,25ΦΡΕΖ		
PΦ-040006	10X1,25 ΒΙΖ		
PΦ-040004	12X1 ΒΙΖ.		
PΦ-040005	3\8X24 ΦΡΕΖ		
PΦ-040007	3\8X24 ΒΙΖ		



ΕΞΑΕΡΩΤΗΡΕΣ ΦΡΕΝΩΝ

PΦ-150000	6X1		
PΦ-150001	7X1		
PΦ-150004	8X1,25 FIAT		
PΦ-150002	10X1		
PΦ-150003	3\8X24		
PΦ-150005	8X1,25MERCEDES		
PΦ-150006	7\16x24		
PΦ-150007	8x1		



ΤΑΦ ΟΡΓΑΝΩΝ ΟΡΕΙΧΑΛΚΙΝΑ

PΦ-150010	1\8		
PΦ-150014	1\4		
PΦ-150011	10X1		
PΦ-150012	12X1,5		
PΦ-150013	14X1,5		
PΦ-150016	16X1,5		
PΦ-150017	18X1,5		



ΠΑΞΙΜΑΔΙΑ ΣΙΔ/ΝΩΝ ΜΠΕΚ

PΦ-100023	12X1,5		
PΦ-100024	14X1,5		

ΡΟΔΕΛΕΣ ΜΠΕΚ

PΦ-010024	12		
PΦ-010025	14		

ΚΩΝΟΙ ΚΟΛΗΤΟΙ ΜΠΕΚ

PΦ-100025	12		
PΦ-100026	14		
PΦ-100027	ΟΔΗΓΟΙ		



ΡΑΚΟΡ ΘΕΡΜΟΜΕΤΡΟΥ

PΦ-150020	14X1,5	10X1		
PΦ-150021	16X1,5	10X1		
PΦ-150022	18X1,5	10X1		
PΦ-150023	5/8X18	10X1		
PΦ-150024	3/8 BSP	10X1		
PΦ-150025	1/2 BSP	10X1		



ΡΑΚΟΡ FORD ΠΕΤΡΕΛΑΙΟΥ 1/2X20-5/16

PΦ-070013	ΙΣΙΟ 1/2X20-5/16			
PΦ-070014	ΓΩΝΙΑ 1/2X20			
PΦ-070022	7/16 αρσ.τρελλό			

ΡΑΚΟΡ ΑΕΡΟΣ ΑΥΤΟΜΑΤΑ ΟΡΕΙΧΑΛΚΙΝΑ ΝΙΚΕΛΩΜΕΝΑ



ΜΑΣΤΟΙ ΒΑΣΗ B.S.P.T (κωνικό)

ΚΩΔΙΚΟΣ	ΣΩΛΗΝΑ	ΒΑΣΗ	€	+ΦΠΑ
MA-110418	4	1/8		
MA-110414		1/4		
MA-110618	6	1/8		
MA-110614		1/4		
MA-110818	8	1/8		
MA-110814		1/4		
MA-110838		3/8		
MA-111014	10	1/4		
MA-111038		3/8		
MA-111012		1/2		
MA-111214	12	1/4		
MA-111238		3/8		
MA-111212		1/2		
MA-111438	14	3/8		
MA-111412		1/2		



μαστοί βάση μετρικό

MA-1203M3	3	M3		
MA-1203M5		M5		
MA-1204M5	4	M5		
MA-1204M6		M6		
MA-1206M5	6	M5		
MA-1206M6		M6		
MA-120612		12X1		
MA-126125		12X1,25		
MA-120615		12X1,5		
MA-120815	8	12X1,5		



Μαστοί σε ίντσα βάση NPT

ΚΩΔΙΚΟΣ	ΣΩΛΗΝΑ	ΒΑΣΗ	€	+ΦΠΑ
PN-111818	1/8	1/8		
PN-111418	1/4	1/8		
PN-111414		1/4		
PN-113814	3/8	1/4		
PN-113838		3/8		
PN-113812		1/2		
PN-111238	1/2	3/8		
PN-111212		1/2		

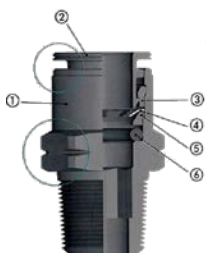

ΜΑΣΤΟΙ ΘΗΛΥΚΟ B.S.P.



MA-130418	4	1/8		
MA-130618	6	1/8		
MA-130614		1/4		
MA-130818	8	1/8		
MA-130814		1/4		
MA-131014		10	1/4	

ΜΑΣΤΟΙ ΘΗΛΥΚΟ σε ίντσα

PN-131418	1/4	1/8		
PN-131414		1/4		
PN-133814	3/8	1/4		
PN-133838		3/8		

ΓΩΝΙΕΣ B.S.P.T. ΠΕΡΙΣΤΡΟΦΙΚΕΣ



MA-150418	4	1/8		
MA-150414		1/4		
MA-150618	6	1/8		
MA-150614		1/4		
MA-150818	8	1/8		
MA-150814		1/4		
MA-150838		3/8		
MA-151014	10	1/4		
MA-151038		3/8		
MA-151214	12	1/4		
MA-151238		3/8		
MA-151438	14	3/8		
MA-151412		1/2		



Γωνίες βάση μετρικό

MA-1604M5	4	M5		
MA-1604M6		M6		
MA-1606M5	6	M5		
MA-1606M6		M6		
MA-166125		12X1,25		
MA-160615		12X1,5		
MA-160815		8	12X1,5	



Γωνίες σε ίντσα βάση NPT

ΚΩΔΙΚΟΣ	ΣΩΛΗΝΑ	ΒΑΣΗ	€	+ΦΠΑ
PN-151818	1/8	1/8		
PN-151418	1/4	1/8		
PN-151414		1/4		
PN-153814	3/8	1/4		
PN-153838		3/8		
PN-151238		3/8		
PN-151212	1/2	1/2		

Η σειρά των αυτόματων ρακόρ είναι κατάλληλη για σωλήνες:









PA 11 RILSAN-NYLON 6 -P.U. elastolan Πίεση -0.99εως 15 bar WP

σε θερμοκρασία από -20 εως +70 οC.

Κατασκευασμένα από τα εξής υλικά.

- 1) σωμα ορειχαλκίνο UNI EN 12164-5
- 2) Δακτύλιος απόσφυξης ορειχαλκίνο
- 3) Αποστάτης συγκρατησης Acetal Resin
- 4) Δακτυλίδι σύσφυξης ατσάλι inox
- 5) Δακτυλίδι προστασίας Acetal Resin
- 6) O/R από NBR



ΣΥΝΔΕΣΜΟΙ ΑΥΤΟΜΑΤΟΙ					ΤΑΦ ΑΥΤΟΜΑΤΑ					ΤΑΦ Β.Σ.Ρ.Τ ΜΕΣΗ ΑΡΣ. ΤΡΕΛΛΟ					
															
ΚΩΔΙΚΟΣ	ΣΩΛ	€	+ΦΠΑ		ΚΩΔΙΚΟΣ	ΣΩΛΗΝΑ	€	+ΦΠΑ		ΚΩΔΙΚΟΣ	ΣΩΛ	ΒΑΣΗ	€	+ΦΠΑ	
MA-260300	3				MA-290303	3				MA-200418	4	1/8			
MA-260400	4				MA-290404	4				MA-200618	6	1/8			
MA-260500	5				MA-290505	5				MA-200614		1/4			
MA-260600	6				MA-290606	6				MA-200818	8	1/8			
MA-260800	8				MA-290808	8				MA-200814		1/4			
MA-260909	9				MA-291010	10				MA-201014	10	1/4			
MA-261000	10				MA-291212	12				MA-201238	12	3/8			
MA-261111	11				MA-291414	14				ΤΑΦ Β.Σ.Ρ.Τ ΑΚΡΗ ΑΡΣ. ΤΡΕΛΛΟ					
MA-261200	12				MA-291515	15									
MA-261400	14				MA-291616	16				MA-230418	4	1/8			
MA-261515	15				PN-291818	1/8				MA-230618	6	1/8			
MA-261616	16				PN-291414	1/4				MA-230614		1/4			
MA-260604	6 - 4				PN-293838	3/8				MA-230818	8	1/8			
MA-260806	8 - 6				PN-291313	1/2				MA-230814		1/4			
MA-261008	10 - 8				ΣΥΝΔΕΣΜΟΙ ΚΟΝΤΡΑ					MA-231014	10	1/4			
PN-261818	1/8									MA-231238	12	3/8			
PN-261414	1/4				ΚΩΔΙΚΟΣ					ΚΟΡ ΣΥΣΤΟΛΙΚΟ					
PN-263838	3/8				MA-270404	4	12X1	€	+ΦΠΑ						
PN-261313	1/2				MA-270606	6	14X1			ΚΩΔΙΚΟΣ					
ΓΩΝΙΕΣ ΑΥΤΟΜΑΤΕΣ					MA-270808	8	16X1			MA-250304	3	4			
					MA-271010	10	18X1			MA-250406	4	6			
					MA-271212	12	20X1			MA-250408		8			
					ΑΝΤΙΣΤΡΟΦΟ ΑΡΣΕΝΙΚΟ					MA-250604	6	4			
										MA-250608		8			
					MA-280303	3				MA-250610		10			
					MA-280404	4				MA-250612		12			
					MA-280606	6				MA-250806	8	6			
					MA-280808	8				MA-250810		10			
					MA-281010	10				MA-250812	12				
					MA-281212	12				MA-251012	10	12			
					MA-281414	14				MA-251214	12	14			
					MA-281616	16				PN-251438	1/4	3/8			
					PN-281818	1/8				PN-251412		1/2			
					PN-281414	1/4				PN-253812	3/8	1/2			
					PN-283838	3/8				ΡΥΘΙΣΤΕΣ ΑΕΡΟΣ					
					PN-281313	1/2									
ΤΑΦ Υψιλον					MA-380818	8	1/8			MA-180618	6	1/8			
					MA-380814		1/4				MA-180818	8	1/8		
					MA-381014	10	1/4								
					MA-381238	12	3/8								
					PN-381418	1/4	1/8								
					PN-381414		1/4								
					PN-383814	3/8	1/4								
					PN-383838		3/8								
					PN-381238	1/2	3/8								
					PN-381212		1/2								

MT
LINE

**SAFETY
AND
STABILITY
ON THE MOVE**

0-16 BAR



ΜΑΣΤΟΙ ΒΑΣΗΣ

ΣΕΙΡΑ MT



ΓΩΝΙΕΣ ΒΑΣΗΣ

ΣΕΙΡΑ MT

ΚΩΔΙΚΟΣ	ΣΩΛΗΝ	ΒΑΣΗ	€	+ΦΠΑ
MT12 06 M10	6	10x1		
MT12 06 M12	6	12x1,5		
MT12 06 M14	6	14x1,5		
MT12 06 M16	6	16x1,5		
MT12 08 M10	8	10x1		
MT12 08 M12	8	12x1,5		
MT12 08 M14	8	14x1,5		
MT12 08 M16	8	16x1,5		
MT12 08 M22	8	22x1,5		
MT12 10 M12	10	12x1,5		
MT12 10 M14	10	14x1,5		
MT12 10 M16	10	16x1,5		
MT12 10 M22	10	22x1,5		
MT12 12 M12	12	12x1,5		
MT12 12 M14	12	14x1,5		
MT12 12 M16	12	16x1,5		
MT12 12 M22	12	22x1,5		
MT12 15 M16	15	16x1,5		
MT12 15 M22	15	22x1,5		
MT12 16 M16	16	16x1,5		
MT12 16 M22	16	22x1,5		
MT12 18 M22	18	22x1,5		

ΚΩΔΙΚΟΣ	ΣΩΛΗΝ	ΒΑΣΗ	€	+ΦΠΑ
MT1606 M10	6	10x1		
MT1606 M12	6	12x1,5		
MT1606 M14	6	14x1,5		
MT1606 M16	6	16x1,5		
MT1608 M10	8	10x1		
MT1608 M12	8	12x1,5		
MT1608 M14	8	14x1,5		
MT1608 M16	8	16x1,5		
MT1608 M22	8	22x1,5		
MT1610 M12	10	12x1,5		
MT1610 M14	10	14x1,5		
MT1610 M16	10	16x1,5		
MT1610 M22	10	22x1,5		
MT1612 M12	12	12x1,5		
MT1612 M14	12	14x1,5		
MT1612 M16	12	16x1,5		
MT1612 M22	12	22x1,5		
MT1615 M16	15	16x1,5		
MT1615 M22	15	22x1,5		
MT1616 M16	16	16x1,5		
MT1616 M22	16	22x1,5		
MT1618 M22	18	22x1,5		

Η νέα σειρά αυτόματων ρακόρ σχεδιασμένη ειδικά για τὰ πνευματικά συστήματα των φορτηγών. Διαθέτουν προστατευτική τάπα για προστασία από βρωμίες και υγρασία των εσωτερικών μερών του ρακόρ, μέγιστη ασφάλεια λόγω της εσωτερικής αντίστασης και απασφαλίζουν εύκολα με το εργαλείο.



C.Matic's MT fittings achieved the TUV Product certifications according to DIN 74324:1996 - DIN EN ISO 9227:2017-07 and DIN EN 60068-2-6:2008



MADE IN ITALY

ΣΥΝΔΕΣΜΟΙ



ΣΕΙΡΑ ΜΤ

ΚΩΔΙΚΟΣ	ΣΩΛΗΝ	€	+ΦΠΑ
MT-260606	6		
MT-260808	8		
MT-261010	10		
MT-261212	12		
MT-261515	15		
MT-261616	16		
MT-261818	18		



ΓΩΝΙΕΣ ΣΥΝΔΕΣΜΟΙ ΣΕΙΡΑ ΜΤ

ΚΩΔΙΚΟΣ	ΣΩΛΗΝ	€	+ΦΠΑ
MT-280606	6		
MT-280808	8		
MT-281010	10		
MT-281212	12		
MT-281515	15		
MT-281616	16		
MT-281818	18		



ΤΑΦ

ΣΕΙΡΑ ΜΤ

ΚΩΔΙΚΟΣ	ΣΩΛΗΝ	€	+ΦΠΑ
MT-290606	6		
MT-290808	8		
MT-291010	10		
MT-291212	12		
MT-291515	15		
MT-291616	16		
MT-291818	18		



ΤΑΦ ΜΕΣΗ ΒΑΣΗ

ΣΕΙΡΑ ΜΤ

ΚΩΔΙΚΟΣ	ΣΩΛΗΝ	ΒΑΣΗ	€	+ΦΠΑ
MT-2106M10	6	10x1		
MT-2106M12	6	12x1,5		
MT-2106M14	6	14x1,5		
MT-2106M16	6	16x1,5		
MT-2108M10	8	10x1		
MT-2108M12	8	12x1,5		
MT-2108M14	8	14x1,5		
MT-2108M16	8	16x1,5		
MT-2108M22	8	22x1,5		
MT-2110M12	10	12x1,5		
MT-2110M14	10	14x1,5		
MT-2110M16	10	16x1,5		
MT-2110M22	10	22x1,5		
MT-2112M12	12	12x1,5		
MT-2112M14	12	14x1,5		
MT-2112M16	12	16x1,5		
MT-2112M22	12	22x1,5		
MT-2115M16	15	16x1,5		
MT-2115M22	15	22x1,5		
MT-2116M16	16	16x1,5		
MT-2116M22	16	22x1,5		
MT-2118M22	18	22x1,5		



ΤΑΦ ΑΚΡΗ ΒΑΣΗ

ΣΕΙΡΑ ΜΤ

ΚΩΔΙΚΟΣ	ΣΩΛΗΝ	ΒΑΣΗ	€	+ΦΠΑ
MT-2406 M10	6	10x1		
MT-2406 M12	6	12x1,5		
MT-2406 M14	6	14x1,5		
MT-2406 M16	6	16x1,5		
MT-2408 M10	8	10x1		
MT-2408 M12	8	12x1,5		
MT-2408 M14	8	14x1,5		
MT-2408 M16	8	16x1,5		
MT-2408 M22	8	22x1,5		
MT-2410 M12	10	12x1,5		
MT-2410 M14	10	14x1,5		
MT-2410 M16	10	16x1,5		
MT-2410 M22	10	22x1,5		
MT-2412 M12	12	12x1,5		
MT-2412 M14	12	14x1,5		
MT-2412 M16	12	16x1,5		
MT-2412 M22	12	22x1,5		
MT-2415 M16	15	16x1,5		
MT-2415 M22	15	22x1,5		
MT-2416 M16	16	16x1,5		
MT-2416 M22	16	22x1,5		
MT-2418 M22	18	22x1,5		



ΕΡΓΑΛΕΙΟ ΑΠΟΣΥΝΔΕΣΗΣ

ΚΩΔΙΚΟΣ	ΓΙΑ ΣΩΛΗΝΕΣ	€	+ΦΠΑ
MT-Σ10001	6-8-10-12		
MT-Σ10002	15-16-18		



ΚΟΦΤΕΣ ΣΩΛΗΝΩΝ

ΚΩΔΙΚΟΣ	ΠΕΡΙΓΡΑΦΗ	ΚΟΠΗ	€	€+ΦΠΑ
ΣΒ-110000	ΜΕΤΑΛΚΟΣ 2-12mm			
ΣΒ-110001	ΜΕΤΑΛΚΟΣ 2-28mm			
ΣΒ-120000	ΠΛΑΣΤΙΚΟΣ 2-20mm			

ΛΑΜΑΚΙΑ ΑΝΤΑΛΛΑΚΤΙΚΑ

ΣΒ-110003	ΜΕΤΑΛΚΟΥ 2-12mm			
ΣΒ-110002	ΜΕΤΑΛΚΟΥ 2-28mm			
ΣΒ-120001	ΠΛΑΣΤΙΚΟΥ 2-20mm			

ΡΑΚΟΡ ΑΥΤΟΛΙΠΑΝΣΗΣ ΑΥΤΟΜΑΤΑ 60 BAR



ΜΑΣΤΟΙ ΣΕΙΡΑ MP 80bar					ΓΩΝΙΑ ΣΕΙΡΑ MP 80bar				
ΚΩΔΙΚΟΣ	ΣΩΛΗΝΑ	ΒΑΣΗ	€	+ΦΠΑ	ΚΩΔΙΚΟΣ	ΣΩΛΗΝΑ	ΒΑΣΗ	€	+ΦΠΑ
MP-110418	4	1/8			MP-150418	4	1/8		
MP-1104M6		6X1			MP-1504M6		6X1		
MP-1104M8		8X1			MP-1504M8		8X1		
MP-1104M1		10X1			MP-1504M1		10X1		
MP-110618	6	1/8			MP-150618	6	1/8		
MP-1106M6		6X1			MP-1506M6		6X1		
MP-1106M8		8X1			MP-1506M8		8X1		
MP-1106M1		10X1			MP-1506M1		10X1		

ΣΥΝΔΕΣΜΟΙ ΣΕΙΡΑ MP 80bar			
ΚΩΔΙΚΟΣ	ΣΩΛΗΝΑ	€	+ΦΠΑ
MP-260404	4		
MP-260606	6		
MP-260808	8		

ΤΑΦ ΣΕΙΡΑ MP 80bar			
ΚΩΔΙΚΟΣ	ΣΩΛΗΝΑ	€	+ΦΠΑ
MP-290404	4		
MP-290606	6		
MP-290808	8		

ΣΩΛΗΝ ΡΑ12 NSR ΑΥΤΟΛΙΠΑΝΣΗΣ - ΥΔΡΟΝΕΦΩΣΗΣ



ΚΩΔΙΚΟΣ	ΔΙΑΣΤΑΣΗ	bar	€	+ΦΠΑ
MP-110402	4X2	91		
MP-110603	6X3	93		

ΡΑΚΟΡ ΑΥΤΟΛΙΠΑΝΣΗΣ ΑΥΤΟΜΑΤΑ 150 BAR



ΜΑΣΤΟΙ ΣΕΙΡΑ HP 150bar					ΓΩΝΙΕΣ ΣΕΙΡΑ HP 150bar				
ΚΩΔΙΚΟΣ	ΣΩΛΗΝΑ	ΒΑΣΗ	€	+ΦΠΑ	ΚΩΔΙΚΟΣ	ΣΩΛΗΝΑ	ΒΑΣΗ	€	+ΦΠΑ
HP-110418	4	1/8			HP-180418	4	1/8		
HP-1104M6		6X1			HP-1804M6		6X1		
HP-1104M8		8X1			HP-1804M8		8X1		
HP-1104M1		10X1			HP-1804M1		10X1		
HP-1106M6	6	6X1			HP-1806M6	6	6X1		
HP-1106M8		8X1			HP-1806M8		8X1		
HP-1106M1		10X1			HP-1806M1		10X1		

ΡΑΚΟΡ ΑΥΤΟΜΑΤΑ ΥΔΡΟΝΕΦΩΣΗΣ 80 BAR

ΜΑΣΤΟΣ ΥΔΡΟΝΕΦΩΣΗΣ			
ΚΩΔΙΚΟΣ	ΔΙΑΣΤΑΣΗ	bar	€
ΜΦ-111414	1\4-1\4		
ΜΦ-113838	3\8-3\8		

ΣΩΛΗΝ ΡΑ12 NSR ΥΔΡΟΝΕΦΩΣΗΣ			
ΚΩΔΙΚΟΣ	ΔΙΑΣΤΑΣΗ	bar	€
ΜΦ-010006	1\4	95bar	
ΜΦ-010010	3\8	87 bar	

ΤΑΦ ΣΥΝΔΕΣΜΟΣ ΥΔΡΟΝΕΦΩΣΗΣ			
ΚΩΔΙΚΟΣ	ΔΙΑΣΤΑΣΗ	bar	€
ΜΦ-291414	1\4		
ΜΦ-293838	3\8		

ΤΑΦ ΓΙΑ ΜΠΕΚ 10-24 UNC			
ΚΩΔΙΚΟΣ	ΔΙΑΣΤΑΣΗ	bar	€
ΜΦ-261010	10 mm		
ΜΦ-601414	1\4		
ΜΦ-603838	3\8		

ΤΕΛΟΣ ΓΡΑΜΜΗΣ - ΜΠΕΚ 10-24 UNC			
ΚΩΔΙΚΟΣ	ΔΙΑΣΤΑΣΗ	bar	€
ΜΦ-610014	1\4		
ΜΦ-610038	3\8		



ΜΠΕΚ ΥΔΡΟΝΕΦΩΣΗΣ			
ΚΩΔΙΚΟΣ	ΔΙΑΣΤΑΣΗ	bar	€
ΜΦ-990015	0,15		
ΜΦ-990020	0,2		
ΜΦ-990030	0,3		
ΜΦ-990040	0,4		

ΠΑΡΟΧΗ ΝΕΡΟΥ LIT/MIN				
size	35 bar	45 bar	70 bar	84 bar
0,15	0,033	0,0338	0,0460	0,0510
0,2	0,0568	0,0643	0,0787	0,0980
0,3	0,0790	0,0867	0,1080	0,1590
0,4	0,1048	0,1190	0,1483	0,1950

ΡΑΚΟΡ ΑΥΤΟΜΑΤΑ ΑΕΡΟΣ ΠΛΑΣΤΙΚΑ



**ΤΑΦ Β.Σ.Ρ.Τ
ΜΕΣΗ ΑΡΣΕΝΙΚΟ**



ΣΥΝΔΕΣΜΟΙ

ΚΩΔΙΚΟΣ	ΣΩΛΗΝΑ	€	+ΦΠΑ
ΠΛ-260404	4		
ΠΛ-260505	5		
ΠΛ-260606	6		
ΠΛ-260707	7		
ΠΛ-260808	8		
ΠΛ-261010	10		
ΠΛ-261212	12		
ΠΛ-261414	14		
ΠΛ-261616	16		
ΠΛ-260604	6 - 4		
ΠΛ-260806	8 - 6		
ΠΛ-261008	10 - 8		
ΠΛ-261210	12-10		

ΜΑΣΤΟΙ Β.Σ.Ρ.Τ

ΚΩΔΙΚΟΣ	ΣΩΛΗΝΑ	€	+ΦΠΑ	ΚΩΔΙΚΟΣ	ΣΩΛΗΝΑ	ΒΑΣΗ	€	+ΦΠΑ
ΠΛ-110418	4	1/8		ΠΛ-200418	4	1/8		
ΠΛ-110414	4	1/4		ΠΛ-200618	6	1/8		
ΠΛ-110618	6	1/8		ΠΛ-200614	6	1/4		
ΠΛ-110614	6	1/4		ΠΛ-200818	8	1/8		
ΠΛ-110818	8	1/8		ΠΛ-200814	8	1/4		
ΠΛ-110814	8	1/4		ΠΛ-201014	10	1/4		
ΠΛ-111014	10	1/4		ΠΛ-201214	12	1/4		
ΠΛ-111238	12	3/8		ΠΛ-201238	12	3/8		
ΠΛ-111212	12	1/2						



ΤΑΦ

ΠΛ-290400	4		
ΠΛ-290500	5		
ΠΛ-290600	6		
ΠΛ-290800	8		
ΠΛ-291000	10		
ΠΛ-291200	12		
ΠΛ-291400	14		
ΠΛ-291600	16		

ΓΩΝΙΕΣ Β.Σ.Ρ & Ο/Ρ

ΠΛ-150418	4	1/8	
ΠΛ-150414	4	1/4	
ΠΛ-150618	6	1/8	
ΠΛ-150614	6	1/4	
ΠΛ-150818	8	1/8	
ΠΛ-150814	8	1/4	
ΠΛ-151014	10	1/4	
ΠΛ-151214	12	1/4	
ΠΛ-151238	12	3/8	
ΠΛ-151212	12	1/2	



**ΤΑΦ Β.Σ.Ρ.Τ
ΑΚΡΗ ΑΡΣΕΝΙΚΟ**

ΠΛ-230418	4	1/8	
ΠΛ-230618	6	1/8	
ΠΛ-230614	6	1/4	
ΠΛ-230818	8	1/8	
ΠΛ-230814	8	1/4	
ΠΛ-231014	10	1/4	
ΠΛ-231214	12	1/4	
ΠΛ-231238	12	3/8	



ΓΩΝΙΕΣ

ΠΛ-280400	4		
ΠΛ-280500	5		
ΠΛ-280600	6		
ΠΛ-280800	8		
ΠΛ-281000	10		
ΠΛ-281200	12		
ΠΛ-281400	14		
ΠΛ-281600	16		

**ΓΩΝΙΑ ΜΕΤΑΒΛΗΤΗΣ
BSP Ο/Ρ**

ΠΛ-160418	4	1/8	
ΠΛ-160618	6	1/8	
ΠΛ-160614	6	1/4	
ΠΛ-160818	8	1/8	
ΠΛ-160814	8	1/4	
ΠΛ-161014	10	1/4	
ΠΛ-161214	12	1/4	
ΠΛ-161238	12	3/8	



**ΣΥΝΔΕΣΜΟΙ
ΚΟΝΤΡΑ**

ΠΛ-270404	4		
ΠΛ-270606	6		
ΠΛ-270808	8		
ΠΛ-271010	10		
ΠΛ-271212	12		



ΚΟΡ ΣΥΣΤΟΛΙΚΟ

ΚΩΔΙΚΟΣ	ΣΩΛ	βισμα	€	+ΦΠΑ
ΠΛ-250406	4	6		
ΠΛ-250408	4	8		
ΠΛ-250608	6	8		
ΠΛ-250610	6	10		
ΠΛ-250810	8	10		
ΠΛ-250812	8	12		
ΠΛ-251012	10	12		



ΣΤΑΥΡΟΙ

ΠΛ-300400	4		
ΠΛ-300600	6		
ΠΛ-300800	8		
ΠΛ-301000	10		
ΠΛ-301200	12		

ΤΑΦ ΥΨΙΛΟΝ

ΠΛ-370400	4		
ΠΛ-370500	5		
ΠΛ-370600	6		
ΠΛ-370800	8		
ΠΛ-371000	10		
ΠΛ-371200	12		

ΡΑΚΟΡ ΟΡΕΙΧΑΛΚΙΝΑ ΜΕ ΜΠΙΜΠΙΚΙ



ΜΑΣΤΟΙ ΒΑΣΗΣ BSP-T



ΣΥΝΔΕΣΜΟΙ



ΤΑΦ ΜΕΣΗ N.P.T

ΚΩΔΙΚΟΣ	ΣΩΛΗΝ	ΒΑΣΗ	€	+ΦΠΑ	ΚΩΔΙΚΟΣ	ΣΩΛΗΝ	€	+ΦΠΑ	ΚΩΔΙΚΟΣ	ΣΩΛΗΝ	ΒΑΣΗ	€	+ΦΠΑ	
MO-110418	4	1/8			MO-140400	4			MO-190418	4	1/8			
MO-110518	5	1/8			MO-140500	5			MO-190618	6	1/8			
MO-110618	6	1/8			MO-140600	6			MO-190614		1/4			
MO-110614		1/4			MO-140800	8			MO-190818	8	1/8			
MO-110638		3/8			MO-141000	10			MO-190814		1/4			
MO-110612		1/2			MO-141200	12			MO-190838		3/8			
MO-110818	8	1/8			MO-141500	15			MO-191014		1/4			
MO-110814		1/4			<p>ΓΩΝΙΕΣ Α-Α ΣΥΝΔΕΣΜΟΙ</p>	MO-191038	10	3/8						
MO-110838		3/8				MO-191012		1/2						
MO-111014	10	1/4				MO-191214	12	1/4						
MO-111038		3/8				MO-191238		3/8						
MO-111012	1/2				MO-191212	1/2								
MO-111214	12	1/4			MO-191512	15			<p>ΤΑΦ ΑΚΡΗ N.P.T</p>					
MO-111238		3/8			ΚΩΔΙΚΟΣ	ΣΩΛΗΝ	ΒΑΣΗ	€		+ΦΠΑ				
MO-111212		1/2			MO-200418	4	1/8							
MO-111512	15	1/2			MO-200618	6	1/8							
MO-1204M5	4	M5			MO-200614		1/4							



ΘΗΛΥΚΟ B.S.P. ΓΙΑ ΣΩΛΗΝΑ

MO-130614	6	1/4		
MO-130814	8	1/4		
MO-130838		3/8		
MO-131014	10	1/4		
MO-131038		3/8		
MO-131012		1/2		



ΤΑΦ Α-Α-Α ΣΥΝΔΕΣΜΟΙ

ΚΩΔΙΚΟΣ	ΣΩΛΗΝ	€	+ΦΠΑ
MO-180400	4		
MO-180500	5		
MO-180600	6		
MO-180800	8		
MO-181000	10		
MO-181200	12		
MO-181500	15		



ΤΑΦ ΑΚΡΗ N.P.T

ΚΩΔΙΚΟΣ	ΣΩΛΗΝ	ΒΑΣΗ	€	+ΦΠΑ
MO-200418	4	1/8		
MO-200618	6	1/8		
MO-200614		1/4		
MO-200818	8	1/8		
MO-200814		1/4		
MO-200838		3/8		
MO-201014	10	1/4		
MO-201038		3/8		
MO-201012		1/2		
MO-201214	12	1/4		
MO-201238		3/8		
MO-201212		1/2		



ΓΩΝΙΕΣ BSP-T

MO-160418	4	1/8		
MO-160518	5	1/8		
MO-160618	6	1/8		
MO-160614	6	1/4		
MO-160818	8	1/8		
MO-160814	8	1/4		
MO-161014	10	1/4		
MO-161038	10	3/8		
MO-161238	12	3/8		
MO-161212	12	1/2		
MO-161412	14	1/2		
MO-161512	15	1/2		



ΣΥΝΔΕΣΜΟΙ ΚΟΝΤΡΑ

MO-150400	4		
MO-150500	5		
MO-150600	6		
MO-150800	8		
MO-151000	10		
MO-151200	12		
MO-151500	15		



ΚΟΡ

ΚΩΔΙΚΟΣ	RZ	ΣΩΛΗΝ	€	+ΦΠΑ
MO-260806	8	6		
MO-261006	10	6		
MO-261008	10	8		
MO-261208	12	8		



ΠΑΞΙΜΑΔΙΑ ΟΡΕΙΧΑΛΚΙΝΑ ΝΙΚΕΛ

ΚΩΔΙΚΟΣ	ΣΩΛΗΝ	ΒΟΛΤΑ	€	+ΦΠΑ
MO-210400	4	8X1		
MO-210500	5	10X1		
MO-210600	6	10X1		
MO-210800	8	12X1		
MO-211000	10	14X1		
MO-211200	12	16X1		
MO-211500	15	20X1		

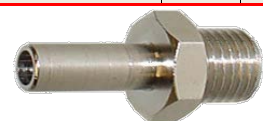

ΑΝΤΙΣΤΡΟΦΑ ΑΡΣΕΝΙΚΑ

ΚΩΔΙΚΟΣ	ΣΩΛΗΝ	ΒΑΣΗ	€	+ΦΠΑ
MO-240418	1/8	4		
MO-240618	1/8	6		
MO-240814	1/4	8		
MO-241014	1/4	10		
MO-241238	3/8	12		
MO-241212	1/2	12		



ΜΠΙΜΠΙΚΙΑ ΟΡΕΙΧΑΛΚΙΝΑ

ΚΩΔΙΚΟΣ	ΣΩΛΗΝ	€	+ΦΠΑ
MO-220465	4		
MO-220565	5		
MO-220675	6		
MO-220875	8		
MO-221095	10		
MO-221295	12		
MO-221510	15		

Κατασκευασμένα από χαλκό DIN 3861 60 bar W.P (Παξιμάδια DIN 3870) για υδραυλικά,πνευματικά συστήματα. Για σωλήνες από: χαλκό , σίδηρο, αλουμίνιο, PA11, NY 6



made in italy

ΤΑΧΥΣΥΝΔΕΣΜΟΙ ΑΕΡΟΣ UNIVERSAL ΙΤΑΛΙΑΣ

Κουμπώνουν με ταχυσύνδεσμούς Ιταλίας NW 6,5 & Γερμανίας NW 7,2.

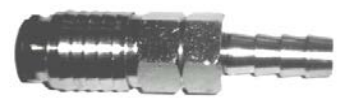

ΑΡΣΕΝΙΚΟ ΣΠΕΙΡΩΜΑ				ΘΗΛΥΚΟ ΣΠΕΙΡΩΜΑ				ΜΕ ΟΥΡΑ ΣΩΛΗΝΑ			
ΚΩΔΙΚΟΣ	ΠΕΡΙΓΡΑΦΗ	€	+ΦΠΑ	ΚΩΔΙΚΟΣ	ΠΕΡΙΓΡΑΦΗ	€	+ΦΠΑ	ΚΩΔΙΚΟΣ	ΠΕΡΙΓΡΑΦΗ	€	+ΦΠΑ
PA-010001	1/4			PA-010101	1/4			PA-010203	1/4		
PA-010002	3/8			PA-010102	3/8			PA-010201	5/16		
PA-010003	1/2			PA-010103	1/2			PA-010202	3/8		



ΚΟΥΜΠΩΜΑ UNI ΟΥΡΑ				ΚΟΥΜΠΩΜΑ UNI ΑΡΣΕΝΙΚΟ				ΚΟΥΜΠΩΜΑ UNI ΘΗΛΥΚΟ			
PA-010301	8mm			PA-010302	1/4			PA-010304	1/4		



ΚΟΥΜΠΩΜΑ UNI ΕΛΑΤΗΡΙΟ				ΑΡΣΕΝΙΚΟ ΕΛΑΤΗΡΙΟ			
PA-010309	6X4			PA-014300	1/8 - 6X4		
PA-010307	8X6			PA-014301	1/4 - 6X4		
PA-010308	10X8			PA-014302	1/4 - 8X6		

ΚΟΥΜΠΩΜΑ UNI ΦΡΕΖΟΒΙΔΑ				ΑΡΣ. ΕΛΑΤΗΡΙΟ ΠΕΡΙΣΤΡΕΦΟΜΕΝΟ				ΘΗΛΥΚΟ ΕΛΑΤΗΡΙΟ			
PA-010306				PA-014310	1/8 - 6X4			PA-014320	1/4 - 6X4		
				PA-014312	1/4 - 6X4			PA-014304	1/4 - 8X6		
				PA-014308	1/4 - 8X6			PA-014305	1/4 - 10X8		
				PA-014313	1/4 - 8X5			PA-014321	3/8 - 12X10		
				PA-014309	1/4 - 10X8						
				PA-014314	1/4-10X6,5						
				PA-014325	1/4-12X10						

ΦΡΕΖΟΒΙΔΑ ΕΛΑΤΗΡΙΟ				ΘΗΛΥΚΟ ΕΛΑΤΗΡΙΟ			
PA-014306	8X6			PA-014320	1/4 - 6X4		
PA-014307	10X8			PA-014304	1/4 - 8X6		

ΤΑΧΥΣΥΝΔΕΣΜΟΙ ΑΕΡΟΣ ΓΕΡΜΑΝΙΑΣ NW 7,2

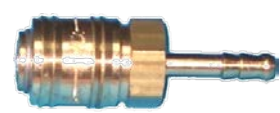
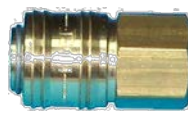

ΑΡΣΕΝΙΚΟ ΣΠΕΙΡΩΜΑ				ΘΗΛΥΚΟ ΣΠΕΙΡΩΜΑ				ΜΕ ΟΥΡΑ ΣΩΛΗΝΑ			
PA-012501	1/4			PA-012601	1/4			PA-012701	1/4		
PA-012502	3/8			PA-012602	3/8			PA-012700	5/16		
PA-012503	1/2			PA-012603	1/2			PA-012702	3/8		
								PA-012703	1/2		



ΚΟΥΜΠΩΜΑ ΟΥΡΑ				ΚΟΥΜΠΩΜΑ ΑΡΣΕΝΙΚΟ				ΚΟΥΜΠΩΜΑ ΘΗΛΥΚΟ			
PA-012801	1/4			PA-012901	1/4			PA-013001	1/4		
PA-012800	5/16										
PA-012802	3/8										
PA-012803	1/2										

ΤΑΧΥΣΥΝΔΕΣΜΟΙ MIGNION NW 5



ΑΡΣΕΝΙΚΟΙ				ΘΗΛΥΚΟΙ				ΚΟΥΜΠΩΜΑ ΑΡΣΕΝΙΚΟ			
PA-010010	1/8			PA-010110	1/8			PA-010311	1/4		
PA-010011	1/4			PA-010111	1/4						



ΚΟΥΜΠΩΜΑ ΟΥΡΑ				ΚΟΥΜΠΩΜΑ ΒΙΔΩΤΟ				ΚΟΥΜΠΩΜΑ ΘΗΛΥΚΟ			
PA-010313	6mm			PA-010315	6X4			PA-010316	1/8		
				PA-010314	8X6			PA-010312	1/4		

ΤΑΧΥΣΥΝΔΕΣΜΟΙ ΑΕΡΟΣ ΚΑΥΑΣΑΚΙ ΙΑΡΑΝ

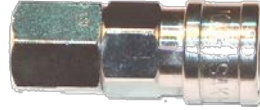

ΑΡΣΕΝΙΚΟ ΣΠΕΙΡΩΜΑ

ΘΗΛΥΚΟ ΣΠΕΙΡΩΜΑ

ΜΕ ΟΥΡΑ ΣΩΛΗΝΑ

ΚΩΔΙΚΟΣ	ΠΕΡΙΓΡΑΦΗ	€	+ΦΠΑ	ΚΩΔΙΚΟΣ	ΠΕΡΙΓΡΑΦΗ	€	+ΦΠΑ	ΚΩΔΙΚΟΣ	ΠΕΡΙΓΡΑΦΗ	€	+ΦΠΑ
PA-012510	1/4			PA-012610	1/4			PA-012710	5/16		
PA-012511	3/8			PA-012611	3/8			PA-012711	3/8		
PA-012512	1/2							PA-012712	1/2 full		
PA-012513	1/2 full										



Η σειρά **Kawasaki 1/2 full** είναι κατάλληλη για μεγάλα αεροεργαλεία

ΚΟΥΜΠΩΜΑ ΟΥΡΑ

ΚΟΥΜΠΩΜΑ ΑΡΣΕΝΙΚΟ

PA-012810	5/16			PA-012910	1/4		
PA-012811	3/8			PA-012911	3/8		
PA-012812	1/2 full			PA-012912	1/2 full		

ΤΑΧΥΣΥΝΔΕΣΜΟΙ ΑΕΡΟΣ ΓΙΓΑΣ ΙΤΑΛΙΑΣ - FULL ΠΑΡΟΧΗ ΑΕΡΟΣ



ΑΡΣΕΝΙΚΟΙ

ΓΙΓΑΣ ΘΗΛΥΚΟΙ

ΓΙΓΑΣ ΜΕ ΟΥΡΑ

ΚΩΔΙΚΟΣ	ΠΕΡΙΓΡΑΦΗ	€	+ΦΠΑ	ΚΩΔΙΚΟΣ	ΠΕΡΙΓΡΑΦΗ	€	+ΦΠΑ	ΚΩΔΙΚΟΣ	ΠΕΡΙΓΡΑΦΗ	€	+ΦΠΑ
PA-012522	3/8			PA-012622	3/8			PA-012721	10mm		
PA-012523	1/2			PA-012623	1/2			PA-012722	13mm		
								PA-012723	15mm		



ΓΙΓΑΣ ΚΟΥΜΠΩΜΑ ΟΥΡΑ

ΓΙΓΑΣ ΚΟΥΜΠΩΜΑ ΑΡΣΕΝΙΚΟ

PA-012822	10mm			PA-012922	3/8		
PA-012823	13mm			PA-012923	1/2		
PA-012824	15mm						

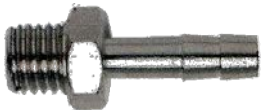

ΑΡΣΕΝΙΚΑ ΜΕ ΟΥΡΑ

ΣΥΝΔΕΣΜΟΣ ΦΡΕΖΟΒΙΔΑΣ

ΦΡΕΖΟΒΙΔΑ (ASTURO)

PA-010801	1/8-6mm			PA-010701	1/4			PA-010401	6mm		
PA-010802	1/8-8mm							PA-010402	8mm		
PA-010803	1/4-6mm							PA-010403	10mm		



ΜΑΣΤΟΣ ΦΡΕΖΟΒΙΔΑΣ

PA-010805	1/4-10mm			PA-010601	1/4		
PA-010806	1/4-12mm						
PA-010808	3/8-9mm						
PA-010809	3/8-10mm						
PA-010810	3/8-12mm						



ΦΡΕΖΟΒΙΔΑ ΒΙΔΩΤΗ

PA-010811	1/2-8mm			PA-010501	1/4			PA-010405	6X14		
PA-010812	1/2-10mm							PA-010406	8X17		

ΠΑΞΙΜΑΔΙ ΦΡΕΖΟΒΙΔΑΣ

PA-010813	1/2-12mm										
PA-010814	1/2-16mm										
PA-010815	3/4-20mm										



ΦΡΕΖΟΒΙΔΑ ΘΗΛΥΚΟ

PA-010816	3/4-25mm			PA-010310	1/4			PA-010705	1/4-6X14		
PA-010817	1"-25mm							PA-010706	1/4-8X17		

ΑΡΣΕΝΙΚΟ ΒΙΔΩΤΟ



ΓΩΝΙΑ ΑΡΣΕΝΙΚΗ ΜΕ ΟΥΡΑ				ΣΥΣΤΟΛΕΣ ΑΜΕΡΙΚΗΣ				ΣΥΣΤΟΛΕΣ ΑΓΓΛΙΑΣ			
ΚΩΔΙΚΟΣ	ΠΕΡΙΓΡΑΦΗ	€	+ΦΠΑ	ΚΩΔΙΚΟΣ	ΑΡΣ-ΘΗΛ	€	+ΦΠΑ	ΚΩΔΙΚΟΣ	ΑΡΣ-ΘΗΛ	€	+ΦΠΑ
PA-011118	1/8-6mm			PA-011901	1/4-1/8			PA-012001	1/8-1/8		
PA-011119	1/8-8mm			PA-011902	3/8-1/8			PA-012002	1/8-1/4		
PA-011120	1/4-6mm			PA-011903	3/8-1/4			PA-012003	1/4-1/4		
PA-011121	1/4-8mm			PA-011904	1/2-1/8			PA-012004	1/8-3/8		
PA-011122	1/4-10mm			PA-011905	1/2-1/4			PA-012005	1/4-3/8		



ΟΥΡΕΣ ΟΡΕΙΧΑΛΚΙΝΕΣ			
ΚΩΔΙΚΟΣ	ΠΕΡΙΓΡΑΦΗ	€	+ΦΠΑ
PA-011706	6mm		
PA-011701	8mm		
PA-011705	10mm		



PA-011906	1/2-3/8			PA-012006	3/8-3/8		
PA-011907	3/4-1/2			PA-012007	1/8-1/2		
PA-011908	1"-1/2			PA-012008	1/4-1/2		
PA-011909	1"-3/4			PA-012009	3/8-1/2		
				PA-012010	1/2-1/2		



ΤΑΦ ΟΥΡΑ ΟΡΕΙΧΑΛΚΙΝΟ			
ΚΩΔΙΚΟΣ	ΠΕΡΙΓΡΑΦΗ	€	+ΦΠΑ
PA-011700	6mm		
PA-011702	8mm		
PA-011707	10mm		



ΔΙΑΚΛΑΔΩΤΗΡΑΣ Α-Θ-Θ				ΜΑΣΤΟΙ ΑΕΡΟΣ			
ΚΩΔΙΚΟΣ	ΠΕΡΙΓΡΑΦΗ	€	+ΦΠΑ	ΚΩΔΙΚΟΣ	ΠΕΡΙΓΡΑΦΗ	€	+ΦΠΑ

PA-011600	1/8			PA-012101	1/8		
PA-011601	1/4			PA-012102	1/4		
PA-011602	3/8			PA-012103	3/8		
PA-011603	1/2			PA-012104	1/2		
				PA-012105	3/4		
				PA-012106	1"		



ΟΥΡΕΣ ΠΛΑΣΤΙΚΕΣ			
ΚΩΔΙΚΟΣ	ΠΕΡΙΓΡΑΦΗ	€	+ΦΠΑ
PA-011720	4mm		
PA-011721	5mm		
PA-011722	6mm		
PA-011723	8mm		
PA-011724	10mm		
PA-011719	12mm		
PA-011725	14mm		
PA-011726	6-4mm		
PA-011727	8-4mm		
PA-011728	8-6mm		
PA-011729	10-8mm		

ΔΙΑΚΛΑΔΩΤΗΡΑΣ Θ-Θ-Θ				ΣΥΣΤΟΛΙΚΟΙ ΜΑΣΤΟΙ ΑΕΡΟΣ			
ΚΩΔΙΚΟΣ	ΠΕΡΙΓΡΑΦΗ	€	+ΦΠΑ	ΚΩΔΙΚΟΣ	ΠΕΡΙΓΡΑΦΗ	€	+ΦΠΑ

PA-011605	1/8			PA-012201	1/4-1/8		
PA-011606	1/4			PA-012202	3/8-1/8		
PA-011607	3/8			PA-012203	3/8-1/4		
PA-011608	1/2			PA-012204	1/2-1/8		
				PA-012205	1/2-1/4		
				PA-012206	1/2-3/8		
				PA-012207	1/2-3/4		
				PA-012208	3/4-1"		



ΤΑΦ ΟΥΡΑ ΠΛΑΣΤΙΚΟ			
ΚΩΔΙΚΟΣ	ΠΕΡΙΓΡΑΦΗ	€	+ΦΠΑ
PA-011710	4mm		
PA-011711	5mm		
PA-011712	6mm		
PA-011713	8mm		
PA-011714	10mm		
PA-011715	12mm		
PA-011716	14mm		
PA-011717	16mm		

ΤΑΠΕΣ ΑΡΣΕΝΙΚΕΣ ΑΕΡΟΣ			
ΚΩΔΙΚΟΣ	ΠΕΡΙΓΡΑΦΗ	€	+ΦΠΑ

PA-012301	1/8			PA-011801	1/8-1/8		
PA-012302	1/4			PA-011802	1/4-1/8		
PA-012303	3/8			PA-011803	1/4-1/4		
PA-012304	1/2			PA-011804	3/8-3/8		
PA-012305	3/4			PA-011805	3/8-1/8		
PA-012306	1"			PA-011806	3/8-1/4		



ΤΑΠΕΣ ΘΗΛΥΚΕΣ ΑΕΡΟΣ			
ΚΩΔΙΚΟΣ	ΠΕΡΙΓΡΑΦΗ	€	+ΦΠΑ

PA-012310	1/8			PA-011807	1/2-1/2		
PA-012311	1/4			PA-011808	1/2-1/8		
PA-012312	3/8			PA-011809	1/2-1/4		
PA-012313	1/2			PA-011810	1/2-3/8		
PA-012314	3/4			PA-011811	3/4-3/4		
				PA-011812	1/2-3/4		
				PA-011813	1"-1"		
				PA-011814	3/4-1"		



ΓΩΝΙΕΣ ΑΕΡΟΣ ΘΗΛ-ΘΗΛ			
ΚΩΔΙΚΟΣ	ΠΕΡΙΓΡΑΦΗ	€	+ΦΠΑ
PA-011001	1/8		
PA-011002	1/4		
PA-011003	3/8		
PA-011004	1/2		



ΓΩΝΙΕΣ ΑΕΡΟΣ ΑΡΣ-ΘΗΛ			
ΚΩΔΙΚΟΣ	ΠΕΡΙΓΡΑΦΗ	€	+ΦΠΑ
PA-011101	1/8		
PA-011102	1/4		
PA-011103	3/8		
PA-011104	1/2		



ΤΑΦ ΑΕΡΟΣ Θ - Θ - Θ			
ΚΩΔΙΚΟΣ	ΠΕΡΙΓΡΑΦΗ	€	+ΦΠΑ
PA-011201	1/8		
PA-011202	1/4		
PA-011203	3/8		
PA-011204	1/2		



ΤΑΦ ΑΕΡΟΣ Θ - Α - Θ			
ΚΩΔΙΚΟΣ	ΠΕΡΙΓΡΑΦΗ	€	+ΦΠΑ
PA-011301	1/8		
PA-011302	1/4		
PA-011303	3/8		
PA-011304	1/2		



ΣΤΑΥΡΟΣ ΑΕΡΟΣ Θ-Θ-Θ-Θ			
ΚΩΔΙΚΟΣ	ΠΕΡΙΓΡΑΦΗ	€	+ΦΠΑ
PA-011401	1/8		
PA-011402	1/4		
PA-011403	3/8		
PA-011404	1/2		



ΣΤΑΥΡΟΣ ΑΕΡΟΣ Α-Θ-Θ-Θ			
ΚΩΔΙΚΟΣ	ΠΕΡΙΓΡΑΦΗ	€	+ΦΠΑ
PA-011501	1/8		
PA-011502	1/4		
PA-011503	3/8		
PA-011504	1/2		



ΡΑΚΟΡ ΑΕΡΟΣ ΕΞΑΕΡΩΣΗΣ			
ΚΩΔΙΚΟΣ	ΠΕΡΙΓΡΑΦΗ	€	+ΦΠΑ
PA-012400	1/8		
PA-012401	1/4		
PA-012402	3/8		

ΡΑΚΟΡ ΠΛΑΣΤΙΚΟΣ ΩΛΗΝΟΣ ΒΙΔΩΤΑ

ΜΑΣΤΟΙ ΑΡΣΕΝΙΚΟΙ			
ΚΩΔΙΚΟΣ	ΠΕΡΙΓΡΑΦΗ	€	+ΦΠΑ
PA-013601	1/8 - 6X4		
PA-013602	1/8 - 8X6		
PA-013603	1/4 - 6X4		
PA-013604	1/4 - 8X6		
PA-013605	1/4 - 10X8		
PA-013606	3/8 - 8X6		
PA-013607	3/8 - 10X8		
PA-013608	3/8 - 12X10		



ΜΑΣΤΟΙ ΘΗΛΥΚΟΙ			
ΚΩΔΙΚΟΣ	ΠΕΡΙΓΡΑΦΗ	€	+ΦΠΑ
PA-013701	1/8 - 6X4		
PA-013702	1/8 - 8X6		
PA-013703	1/4 - 6X4		
PA-013704	1/4 - 8X6		
PA-013705	1/4 - 10X8		



ΓΩΝΙΑ ΑΡΣΕΝΙΚΟ			
ΚΩΔΙΚΟΣ	ΠΕΡΙΓΡΑΦΗ	€	+ΦΠΑ
PA-013801	1/8 - 6X4		
PA-013802	1/8 - 8X6		
PA-013803	1/4 - 6X4		
PA-013804	1/4 - 8X6		
PA-013805	1/4 - 10X8		



ΤΑΦ ΜΕΣΗ Β.Σ.Ρ.Τ			
ΚΩΔΙΚΟΣ	ΠΕΡΙΓΡΑΦΗ	€	+ΦΠΑ
PA-013901	1/8 - 6X4		
PA-013902	1/8 - 8X6		
PA-013903	1/4 - 6X4		
PA-013904	1/4 - 8X6		
PA-013905	1/4 - 10X8		

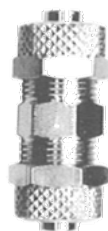

ΣΥΝΔΕΣΜΟΣ			
ΚΩΔΙΚΟΣ	ΠΕΡΙΓΡΑΦΗ	€	+ΦΠΑ
PA-014001	6X4		
PA-014002	8X6		
PA-014003	10X8		
PA-014000	12X10		



ΓΩΝΙΑ ΣΥΝΔΕΣΜΟΣ			
ΚΩΔΙΚΟΣ	ΠΕΡΙΓΡΑΦΗ	€	+ΦΠΑ
PA-014101	6X4		
PA-014102	8X6		
PA-014103	10X8		
PA-014104	12X10		



ΤΑΦ ΣΥΝΔΕΣΜΟΣ			
ΚΩΔΙΚΟΣ	ΠΕΡΙΓΡΑΦΗ	€	+ΦΠΑ
PA-014201	6X4		
PA-014202	8X6		
PA-014203	10X8		
PA-014204	12X10		



ΒΑΝΕΣ ΜΙΝΙ Θ-Θ			
ΚΩΔΙΚΟΣ	ΠΕΡΙΓΡΑΦΗ	€	+ΦΠΑ
PA-014400	1/8		
PA-014401	1/4		
PA-014402	3/8		
PA-014403	1/2		
PA-014404	3/4		



ΒΑΝΕΣ ΜΙΝΙ Α-Θ			
ΚΩΔΙΚΟΣ	ΠΕΡΙΓΡΑΦΗ	€	+ΦΠΑ
PA-014500	1/8		
PA-014501	1/4		
PA-014502	3/8		
PA-014503	1/2		

ΤΑΧΥΣΥΝΔΕΣΜΟΙ - ΣΦΥΚΤΗΡΕΣ ΑΕΡΟΣΦΥΡΑΣ



ΟΥΡΑ			
PA-013101	1/2		
PA-013102	3/4		
PA-013103	1"		



ΑΡΣΕΝΙΚΟΣ			
PA-013201	1/2		
PA-013202	3/4		
PA-013203	1"		

ΛΑΣΤΙΧΑ ΑΕΡΟΣΦΥΡΑΣ

PA-013304	1/2 - 3/4-1"		
PA-013305	1"1/4 - 1"1/2		



ΘΗΛΥΚΟΣ			
PA-013301	1/2		
PA-013302	3/4		
PA-013303	1"		
PA-013306	1" 1/4		
PA-013307	1" 1/2		

ΣΦΥΚΤΗΡΕΣ ΔΙΑΙΡΟΥΜΕΝΟΙ

ΣΦ-030201	20-29(1/2)		
ΣΦ-030202	28-34(3/4)		
ΣΦ-030203	32-40(1")		
ΣΦ-030204	39-49(1"1/4)		
ΣΦ-030205	48-60(1"1/2)		
ΣΦ-030206	60-76(2")		
ΣΦ-030207	74-94 (2"1/2)		
ΣΦ-030208	95-115(3")		
ΣΦ-030210	104-127(3"1/2)		
ΣΦ-030209	127-140(4")		



Δεματικά καλωδίων

DAMESA MIKALOR ΙΣΠΑΝΙΑΣ

πολυαμιδίου μαύρα ενισχυμένα.

ΚΩΔΙΚΟΣ	ΜΕΓΕΘΟΣ	€/100	+ ΦΠΑ
ΣΦ-030501	2,5X140		
ΣΦ-030503	3,6X150		
ΣΦ-030504	3,6X200		
ΣΦ-030505	4,8X200		
ΣΦ-030506	4,8X250		
ΣΦ-030507	4,8X300		
ΣΦ-030508	4,8X370		
ΣΦ-030509	4,8X450		
ΣΦ-030510	4,8X530		



ΚΟΛΛΑ ΣΠΕΙΡΩΜΑΤΩΝ

Για στεγανοποίηση σε νερό, αέρα, λάδι, πετρέλαιο

ΚΩΔΙΚΟΣ	ΠΟΣΟΤΗΤΑ	€	+ ΦΠΑ
ΑΠ-000078	50 gr.		
ΑΠ-000029	250 gr.		



ΣΦΥΚΤΗΡΕΣ ΜΙΚΑΛΟΡ



ASFA-L (9mm)
ASFA-S (12mm)



NORMAL



ΚΩΔΙΚΟΣ	ΜΕΓΕΘΟΣ	πλάτος-κουτί	€	+ ΦΠΑ	ΣΦΥΚΤΗΡΕΣ μίνι (βιδάκι-παξιμάδι) γαλβανιζέ				
ΣΦ-010001	08-16	9mm-200			ΚΩΔΙΚΟΣ	ΜΕΓΕΘΟΣ	πλάτος-κουτί	€	+ ΦΠΑ
ΣΦ-010002	12-22	9mm-200			ΣΦ-020001	6mm	8,4mm-100		
ΣΦ-010003	16-27	9mm-200			ΣΦ-020002	8mm	9mm-100		
ΣΦ-010004	20-32	9mm-200			ΣΦ-020003	9mm	10mm-100		
ΣΦ-010005	25-40	12mm-50			ΣΦ-020004	9,5-10mm	10mm-100		
ΣΦ-010006	30-45	12mm-50			ΣΦ-020005	10-11mm	10mm-100		
ΣΦ-010007	32-50	12mm-50			ΣΦ-020006	12-13mm	10mm-100		
ΣΦ-010008	40-60	12mm-50			ΣΦ-020007	13-14mm	10mm-100		
ΣΦ-010009	50-70	12mm-50			ΣΦ-020008	14-15mm	10mm-100		
ΣΦ-010010	60-80	12mm-50			ΣΦ-020009	15-17mm	10mm-100		
ΣΦ-010011	70-90	12mm-50			ΣΦ-020010	16-18mm	10mm-100		
ΣΦ-010012	80-100	12mm-25			ΣΦ-020011	18-20mm	10mm-100		
ΣΦ-010013	90-110	12mm-25							
ΣΦ-010014	100-120	12mm-25							
ΣΦ-010015	110-130	12mm-25							
ΣΦ-010016	120-140	12mm-25							
ΣΦ-010017	130-150	12mm-25							



**ΣΦΥΚΤΗΡΕΣ ΙΣΠΑΝΙΑΣ
MIKALOR SUPER W1**

Βαρέως τύπου γαλβανιζέ



ΚΩΔΙΚΟΣ	ΜΕΓΕΘΟΣ	πλάτος	κουτί	€	+ ΦΠΑ
ΣΦ-036017	17-19	18	50		
ΣΦ-036020	20-22	18	50		
ΣΦ-036023	23-25	18	50		
ΣΦ-036026	26-28	18	50		
ΣΦ-036029	29-31	20	50		
ΣΦ-036032	32-35	20	50		
ΣΦ-036036	36-39	20	50		
ΣΦ-036040	40-43	20	50		
ΣΦ-036044	44-47	22	50		
ΣΦ-036048	48-51	22	50		
ΣΦ-036052	52-55	22	25		
ΣΦ-036056	56-59	22	25		
ΣΦ-036060	60-63	22	25		
ΣΦ-036064	64-67	22	25		
ΣΦ-036068	68-73	24	25		
ΣΦ-036074	74-79	24	25		
ΣΦ-036080	80-85	24	25		
ΣΦ-036086	86-91	24	25		
ΣΦ-036092	92-97	24	25		
ΣΦ-036098	98-103	24	25		
ΣΦ-036104	104-112	24	25		
ΣΦ-036113	113-121	24	25		
ΣΦ-036122	122-130	24	25		
ΣΦ-036131	131-139	24	10		
ΣΦ-036140	140-148	24	10		
ΣΦ-036149	149-161	24	10		
ΣΦ-036162	162-174	24	10		

NEW



**INOX
ΣΦΥΚΤΗΡΕΣ ΙΣΠΑΝΙΑΣ
MIKALOR SUPRA W4**

ΚΩΔΙΚΟΣ	ΜΕΓΕΘΟΣ	πλάτος	κουτί	€	+ ΦΠΑ
ΣΦ-037017	17-19	18	50		
ΣΦ-037019	19-21	18	50		
ΣΦ-037021	21-23	18	50		
ΣΦ-037023	23-25	18	50		
ΣΦ-037025	25-27	20	50		
ΣΦ-037027	27-29	20	50		
ΣΦ-037029	29-31	20	50		
ΣΦ-037031	31-34	20	50		
ΣΦ-037034	34-37	22	50		
ΣΦ-037040	40-43	22	50		
ΣΦ-037043	43-47	22	50		
ΣΦ-037047	47-51	22	50		
ΣΦ-037051	51-55	22	25		
ΣΦ-037055	55-59	22	25		
ΣΦ-037059	59-63	24	25		
ΣΦ-037063	63-68	24	25		
ΣΦ-037068	68-73	24	25		
ΣΦ-037073	73-79	24	25		
ΣΦ-037079	79-85	24	25		
ΣΦ-037088	85-91	24	25		
ΣΦ-037091	91-97	24	25		
ΣΦ-037097	97-104	24	25		
ΣΦ-037104	104-112	24	25		
ΣΦ-037112	112-121	24	25		
ΣΦ-037121	121-130	24	25		
ΣΦ-037130	130-140	24	10		
ΣΦ-037140	140-150	24	10		

NEW



**INOX
ASFA-L (9mm)
ASFA-S (12mm)**

ΚΩΔΙΚΟΣ	ΜΕΓΕΘΟΣ	πλάτος	κουτί	€	+ ΦΠΑ
ΣΦ-011001	08-16	9mm	200		
ΣΦ-011002	12-22	9mm	200		
ΣΦ-011003	16-27	9mm	200		
ΣΦ-011004	20-32	9mm	200		
ΣΦ-011005	25-40	12mm	50		
ΣΦ-011006	30-45	12mm	50		
ΣΦ-011007	32-50	12mm	50		
ΣΦ-011008	40-60	12mm	50		
ΣΦ-011009	50-70	12mm	50		
ΣΦ-011010	60-80	12mm	50		
ΣΦ-011011	70-90	12mm	50		
ΣΦ-011012	80-100	12mm	25		
ΣΦ-011013	90-110	12mm	25		
ΣΦ-011014	100-120	12mm	25		
ΣΦ-011015	110-130	12mm	25		
ΣΦ-011016	120-140	12mm	25		
ΣΦ-011017	130-150	12mm	25		



AML : Κλίπ γαλβανιζέ

ΚΩΔΙΚΟΣ	ΜΕΓΕΘΟΣ	πλάτος	κουτί	€	+ ΦΠΑ
ΣΦ-030001	8		500		
ΣΦ-030002	9		500		
ΣΦ-030003	10		500		
ΣΦ-030004	11		500		
ΣΦ-030005	12		500		
ΣΦ-030006	14		500		
ΣΦ-030007	20		500		

AAL : Συρμάτινο κλίπ γαλβανιζέ



ΚΩΔΙΚΟΣ	ΜΕΓΕΘΟΣ	πλάτος	κουτί	€	+ ΦΠΑ
ΣΦ-010020	09,3 - 09,9		1.000		
ΣΦ-010021	09,8 - 10,4		1.000		
ΣΦ-010022	10,4 - 11,0		1.000		
ΣΦ-010023	11,0 - 11,6		1.000		
ΣΦ-010024	11,6 - 12,3		1.000		
ΣΦ-010025	12,1 - 13,1		500		
ΣΦ-010026	12,9 - 13,6		500		
ΣΦ-010027	13,6 - 14,4		500		
ΣΦ-010028	14,4 - 15,1		500		

ΡΑΚΟΡ AIR CONDITION ΑΛΟΥΜΙΝΙΟΥ



ΘΗΛΥΚΑ ΜΕ O/R				ΑΜΒΛΕΙΕΣ 45° ΜΕ O/R				ΓΩΝΙΕΣ 90° ΜΕ O/R			
ΚΩΔΙΚΟΣ	ΔΙΑΣΤΑΣΗ	€	+ ΦΠΑ	ΚΩΔΙΚΟΣ	ΔΙΑΣΤΑΣΗ	€	+ ΦΠΑ	ΚΩΔΙΚΟΣ	ΔΙΑΣΤΑΣΗ	€	+ ΦΠΑ
AK-001608	5/8X18-5\16			AK-101608	5/8X18-5\16			AK-201608	5/8X18-5\16		
AK-001910	3/4X16-13\32			AK-101910	3/4X16-13\32			AK-201910	3/4X16-13\32		
AK-002213	7/8X14 -1\2			AK-102213	7/8X14 -1\2			AK-202213	7/8X14 -1\2		
AK-002716	1"1/16-5\8			AK-102716	1"1/16-5\8			AK-202716	1"1/16-5\8		

ΘΗΛΥΚΑ UNF ΚΩΝΟΣ				ΑΜΒΛΕΙΕΣ 45° UNF ΚΩΝΟΣ				ΓΩΝΙΕΣ 90° UNF ΚΩΝΟΣ			
ΚΩΔΙΚΟΣ	ΔΙΑΣΤΑΣΗ	€	+ ΦΠΑ	ΚΩΔΙΚΟΣ	ΔΙΑΣΤΑΣΗ	€	+ ΦΠΑ	ΚΩΔΙΚΟΣ	ΔΙΑΣΤΑΣΗ	€	+ ΦΠΑ
AK-401608	5/8X18-5\16			AK-421608	5/8X18-5\16			AK-411608	5/8X18-5\16		
AK-401910	3/4X16-13\32			AK-421910	3/4X16-13\32			AK-411910	3/4X16-13\32		
AK-402213	7/8X14 -1\2			AK-422213	7/8X14 -1\2			AK-412213	7/8X14 -1\2		
AK-402716	1"1/16-5\8			AK-422716	1"1/16-5\8			AK-412716	1"1/16-5\8		



ΑΡΣΕΝΙΚΑ ΙΣΙΑ ΜΕ O/R				ΑΡΣΕΝΙΚΑ 45° ΜΕ O/R				ΑΡΣΕΝΙΚΑ 90° ΜΕ O/R			
ΚΩΔΙΚΟΣ	ΔΙΑΣΤΑΣΗ	€	+ ΦΠΑ	ΚΩΔΙΚΟΣ	ΔΙΑΣΤΑΣΗ	€	+ ΦΠΑ	ΚΩΔΙΚΟΣ	ΔΙΑΣΤΑΣΗ	€	+ ΦΠΑ
AK-011608	5/8X18-5\16			AK-021608	5/8X18-5\16			AK-031608	5/8X18-5\16		
AK-011910	3/4X16-13\32			AK-021910	3/4X16-13\32			AK-031910	3/4X16-13\32		
AK-012213	7/8X14 -1\2			AK-022213	7/8X14 -1\2			AK-032213	7/8X14 -1\2		
AK-012716	1"1/16-5\8			AK-022716	1"1/16-5\8			AK-032716	1"1/16-5\8		



ΑΡΣΕΝΙΚΑ ΙΣΙΑ ΜΕ ΕΔΡΑ				ΑΡΣΕΝΙΚΑ 45° ΜΕ ΕΔΡΑ				ΑΡΣΕΝΙΚΑ 90° ΜΕ ΕΔΡΑ			
ΚΩΔΙΚΟΣ	ΔΙΑΣΤΑΣΗ	€	+ ΦΠΑ	ΚΩΔΙΚΟΣ	ΔΙΑΣΤΑΣΗ	€	+ ΦΠΑ	ΚΩΔΙΚΟΣ	ΔΙΑΣΤΑΣΗ	€	+ ΦΠΑ
AK-501608	5/8X18-5\16			AK-521608	5/8X18-5\16			AK-511608	5/8X18-5\16		
AK-501910	3/4X16-13\32			AK-521910	3/4X16-13\32			AK-511910	3/4X16-13\32		
AK-502213	7/8X14 -1\2			AK-522213	7/8X14 -1\2			AK-512213	7/8X14 -1\2		
AK-502716	1"1/16-5\8			AK-522716	1"1/16-5\8			AK-512716	1"1/16-5\8		



ΟΥΡΕΣ ΔΙΠΛΗΣ ΕΝΩΣΕΩΣ				ΟΥΡΕΣ ΔΙΠΛΗΣ ΜΕ ΒΑΛΒΙΔΑ				ΘΗΛΥΚΑ O/R & βαλβίδα			
ΚΩΔΙΚΟΣ	ΔΙΑΣΤΑΣΗ	€	+ ΦΠΑ	ΚΩΔΙΚΟΣ	ΔΙΑΣΤΑΣΗ	€	+ ΦΠΑ	ΚΩΔΙΚΟΣ	ΔΙΑΣΤΑΣΗ	€	+ ΦΠΑ
AK-000008	5\16			AK-000108	5\16			AK-091608	5/8X18-5\16		
AK-000010	13\32			AK-000110	13\32			AK-091910	3/4X16-13\32		
AK-000013	1\2			AK-000113	1\2			AK-092213	7/8X14 -1\2		
AK-000016	5\8			AK-000116	5\8			AK-092716	1"1/16-5\8		
AK-000810	5/16-13\32										
AK-001013	13\32-1\2										
AK-001316	1/2-5\8										



ΚΥΑΘΙΑ FREON FLEX

ΚΩΔΙΚΟΣ	ΔΙΑΣΤΑΣΗ	€	+ ΦΠΑ
AK-311008	5\16		
AK-311010	13\32		
AK-311013	1\2		
AK-311016	5\8		



ΛΑΣΤΙΧΑΚΙΑ O/R FREON				ΚΥΑΘΙΑ FREON FLEX REDUCED				ΓΩΝΙΕΣ O/R & βαλβίδα			
ΚΩΔΙΚΟΣ	ΔΙΑΣΤΑΣΗ	€	+ ΦΠΑ	ΚΩΔΙΚΟΣ	ΔΙΑΣΤΑΣΗ	€	+ ΦΠΑ	ΚΩΔΙΚΟΣ	ΔΙΑΣΤΑΣΗ	€	+ ΦΠΑ
AK-350008	5/8X18			AK-310108	5\16			AK-221608	5/8X18-5\16		
AK-350010	3/4X16			AK-310110	13\32			AK-221910	3/4X16-13\32		
AK-350013	7/8X14			AK-310113	1\2			AK-222213	7/8X14 -1\2		
AK-350016	1"1/16X12			AK-310116	5\8			AK-222716	1"1/16-5\8		

1SN ΑΚΑΘΑΡΙΣΤΟ				2SN ΑΚΑΘΑΡΙΣΤΟ				OL 5-7 R7-ΔΙΝΟ				ΜΤΗ1 ΣΥΡΜΑ				OL8 ΔΙΝΑ	
TIPIIN	META	ΔΟΝΤΙΑ	ΔΕΙΚΤΗΣ	TIPIIN	META	ΔΟΝΤΙΑ	ΔΕΙΚΤΗΣ	TIPIIN	META	ΔΟΝΤΙΑ	ΔΕΙΚΤΗΣ	TIPIIN	META	ΔΟΝΤΙΑ			
3/16	19	14,5						14	10,8			15°	12				
1/4	20	16,3		22	17,8			17	13,9			17	14,1		17	13,9	
5/16	22	18,3		24	20,2			19	15,6			19	16				
3/8	24	20,1		25,5	21,4			21	17,8			21	18		21	17,9	
1/2	28,5	23,7		30	25,8			25,5	22,3			25,5	22,5		25,5	22,4	
5/8	32	27		34	28,5			28,5	25,8								
3/4	36	31,5		38	33,3			32	28,6								
1"	43	38,8		46	41			40	36,7								
1SN ΚΑΘΑΡΙΣΜΑ				2SN ΚΑΘΑΡΙΣΜΑ				4SP ΚΑΘΑΡΙΣΜΑ				TEFLON ΜΕ R7 ΚΥΑΘΙΟ					
TIPIIN	META	ΔΟΝΤΙΑ	ΔΕΙΚΤΗΣ	TIPIIN	META	ΔΟΝΤΙΑ	ΔΕΙΚΤΗΣ	TIPIIN	META	ΔΟΝΤΙΑ	ΔΕΙΚΤΗΣ	TIPIIN	META	ΔΟΝΤΙΑ	ΔΕΙΚΤΗΣ		
1/4				21	17,3			23	18,7			3/16	10,3				
5/16				22	18,7							1/4	12,6				
3/8				25	21,8			25	23			5/16	13,4				
1/2				28,5	25			30	26,9			3/8	16,5				
5/8				32	27,6			34	30,5			1/2	21				
3/4				36	32,3			38	34,1			5/8	22,5				
1"				45	41,2			46	41,5			3/4					
1" 1/4	52	46,5		56	50,5			55	50,5			TEFLON ΣΤΙΡΡΑ R7 ΚΥΑΘΙΟ					
1" 1/2	58	53		62	57			62	58			1/2	20,5				
2"	70	66,3		75	69,5			75	70,5			5/8	24,3				
ΣΩΛΗΝΑ 1"1/4 SH ME KYAΘIO Φ 52 MM				52				48				3/4				28	
4SH INTERLOCK				R13- INTERLOCK								1"				34,8	
TIPIIN	META	ΔΟΝΤΙΑ	ΔΕΙΚΤΗΣ	TIPIIN	META	ΔΟΝΤΙΑ	ΔΕΙΚΤΗΣ										
3/4	38	34,1															
1"	46	41,5															
1" 1/4	55	50,5															
1" 1/2	62	58															
2"	78,5	74,2															
ΣΩΛΗΝΕΣ ΠΛΥΣΤΙΚΟΝ																	
TIPIIN	META	ΔΟΝΤΙΑ	ΔΕΙΚΤΗΣ														
	1/4 ΔΙΝΑ HOBBY			17	R7 13,9												
	1/4 1SN 210 BAR			20	R1T 16,3												
	1/4 2SN 400 BAR καθαρίζω			20	R1T 16,3												
	5/162SN 400BAR καθαρίζω			22	22 18,5												
	3/8 2SN400 BAR καθαρίζω			25	19,9												
MICROTUBI																	
	8	7,3															
TEFLON 1/8																	
	10	8,5															
ΦΠΕΝΟΝ 3/16																	
	16	13,2															

Το προτεινόμενο πρεσαδίσκιο είναι με σωλήνα DUNLOP

ΠΙΝΑΚΑΣ ΠΡΕΣΣΑΡΙΣΜΑΤΟΣ ΓΙΑ ΠΑΚΟΡ: ΣΕΙΡΑ "80"

	3/16	1/4	5/16	3/8	1/2	5/8	3/4	1"	1"1/4	1"1/2	2"	
1SN ΑΚΑΘΑΡΙΣΤΟ	ΑΠΡΕΣΑΡΙΣΤΟ	18	19	21	23	27,5	31	35	43	51	58	
	ΠΡΕΣΑΡΙΣΜΕΝΟ	13,5	15	16,5	19	22,8	26,6	30,3	38,1	45,8	52,8	
	ΔΟΝΤΙΑ ΔΕΙΚΤΗΣ ΠΡΕΣΣΑΣ											
2SN ΑΚΑΘΑΡΙΣΤΟ	ΑΠΡΕΣΑΡΙΣΤΟ		21	23	24,5	28	32	36	45	56	64	
	ΠΡΕΣΑΡΙΣΜΕΝΟ		16,6	19	20	23,4	27,4	31,2	39,5	48,4	56	
	ΔΟΝΤΙΑ ΔΕΙΚΤΗΣ ΠΡΕΣΣΑΣ											
1SN ΚΑΘΑΡΙΣΜΕΝΟ	ΑΠΡΕΣΑΡΙΣΤΟ		19	21	23	28	31	35	42	50	56	
	ΠΡΕΣΑΡΙΣΜΕΝΟ		15,2	17,6	19,3	23,6	26,3	30,1	37,6	45,2	50,8	65
	ΚΑΘΑΡΙΣΜΑ ΔΟΝΤΙΑ ΔΕΙΚΤΗΣ ΠΡΕΣΣΑΣ											
2SN ΚΑΘΑΡΙΣΜΕΝΟ	ΑΠΡΕΣΑΡΙΣΤΟ		20	23	24,5	29	33	37	45	55	61	
	ΠΡΕΣΑΡΙΣΜΕΝΟ		16,4	19,7	20,7	24,9	28	31,5	40,9	49,5	55,5	69,2
	ΚΑΘΑΡΙΣΜΑ ΔΟΝΤΙΑ ΔΕΙΚΤΗΣ ΠΡΕΣΣΑΣ		18	17,5	18,5	19,5	22,5	25	32	33,5	39	45,5

	3/16	1/4	5/16	3/8	1/2	
OL5-7-ΜΤΗ1 ΑΚΑΘΑΡΙΣΤΟ	ΑΠΡΕΣΑΡΙΣΤΟ	14	17	19	21	
	ΠΡΕΣ/ΣΜΑ OL7	11,2	13,8	16	17,9	21,6
	ΠΡΕΣ/ΜΑ ΜΤΗ1	11,7	13,9	16,2	18	21,9

	1/4SP	3/8SP	1/2SP	5/8SP	3/4-4SH	1"4SH	1¼4SH	1½4SH	2"4SH	
4SP-4SH ΚΑΘΑΡΙΣΜΕΝΟ	ΑΠΡΕΣΑΡΙΣΤΟ	22	25	29	33	38	45	52	60	
	ΠΡΕΣΑΡΙΣΜΕΝΟ	18,4	21,6	25,3	29,1	34,2	40,7	47,3	55,5	70
	ΚΑΘΑΡΙΣΜΑ ΔΟΝΤΙΑ ΔΕΙΚΤΗΣ ΠΡΕΣΣΑΣ	23	23,5	26,5	28,5	32	44,5	49	56	63,5

Το προτεινόμενο πρόσδεσμο είναι με σωλήνα DUNLOP

Πιστοποιητικό

Σύστημα Διαχείρισης σύμφωνα με
ΕΛΟΤ EN ISO 9001 : 2015

Ο Φορέας Πιστοποίησης TÜV HELLAS (TUV NORD) S.A. επιβεβαιώνει με το παρόν ότι, ως αποτέλεσμα επιθεώρησης, αξιολόγησης και απόφασης πιστοποίησης σύμφωνα με το ISO/IEC 17021-1 : 2015 ο οργανισμός

HYDROFLEX ΕΛΛΑΣ ΑΝΩΝΥΜΗ ΕΤΑΙΡΕΙΑ ΣΥΣΤΗΜΑΤΩΝ
ΚΑΙ ΜΗΧΑΝΗΜΑΤΩΝ ΠΙΕΣΕΩΣ
«HYDROFLEX ΕΛΛΑΣ Α.Ε.»
Λεωφ. Αθηνών 113Α
104 47 Αθήνα
Ελλάδα



εφαρμόζει ένα Σύστημα Διαχείρισης σύμφωνα με τις απαιτήσεις του προτύπου ΕΛΟΤ EN ISO 9001 : 2015, του οποίου η συμμόρφωση θα αξιολογείται κατά τη διάρκεια της τριετούς ισχύος

Πεδίο Εφαρμογής

- Εμπορία Σωλήνων - Ρακόρ Υψηλής Πίεσης, Μηχανημάτων Λίπανσης & Καθαρισμού (Πλαστικά, Σκούπες, Σάρωθρα)
- Τοποθέτηση Ρακόρ Επί Σωλήνων Υψηλής Πίεσης
- Τεχνική Υποστήριξη Μηχανημάτων Μετά την Πώληση
- Συναρμολόγηση Μηχανημάτων Υψηλής Πίεσης Κρύου Νερού

Αριθμός Μητρώου Πιστοποιητικού 041 06 0077
Αρ. Αναφοράς Επιθεώρησης E-0594/2024

Ισχύει από 2024-07-07
Ισχύει μέχρι 2027-07-06
Αρχική Πιστοποίηση 2006

Αθήνα, 04.07.2024

TUV HELLAS (TUV NORD) A.E. Φορέας Πιστοποίησης

TUV HELLAS (TUV NORD) A.E.
Λ. Μεσογείων 282
155 62 Αθήνα, Ελλάδα
tuvhellas.gr



TUV *

TUVNORDGROUP

ΤΡΑΠΕΖΙΚΟΙ ΛΟΓΑΡΙΑΣΜΟΙ

ΕΘΝΙΚΗ

04400506871

IBAN: GR9601100440000004400506871

EUROBANK

00260209560200117336

IBAN: GR0902602090000560200117336

ALPHA

106002320007810

IBAN: GR8201401060106002320007810

ΠΕΙΡΑΙΩΣ

5069032511471

IBAN: GR6801720690005069032511471

OPTIMA

25004150027197

IBAN: GR9403400250025004150027197

Certificate

Management system as per
ELOT EN ISO 9001 : 2015

The Certification Body TÜV HELLAS (TUV NORD) S.A. hereby confirms as a result of the audit, assessment and certification decision according to ISO/IEC 17021-1:2015, that the organization:

HYDROFLEX HELLAS S.A.
113^A, Athinon Ave.
104 47 Athens
Hellas



operates a management system in accordance with the requirements of ELOT EN ISO 9001 : 2015 and will be assessed for conformity within the 3 year term of validity of the certificate.

Scope

- Trade of High Pressure Hoses and Fittings, Lubricating and Washing Systems (High Pressure Washers, Vacuum Cleaners, Sweepers)
- Hose Fitting Installation
- After Sales Service
- Assembly of Cold Water High Pressure Washing Machines

Certificate Registration No. 041 06 0077
Audit Report No. E-0594/2024

Valid from 2024-07-07
Valid until 2027-07-06
Initial certification 2006

Athens, 04.07.2024

TUV HELLAS (TUV NORD) S.A. Certification Body

TUV HELLAS (TUV NORD) S.A.
282, Mesogeion Ave.
155 62 Athens, Greece
tuvhellas.gr



TUV *

TUVNORDGROUP

HYDROFLEX®

HYDROFLEX A.E.

 Λ. ΑΘΗΝΩΝ 113Α Τ.Κ.:10447 ΑΘΗΝΑ



210-3456100
210-3456444
210-3412200



www.hydroflex.gr



hydroflx@otenet.gr



info.hydroflex.hellas@gmail.com



+0306944520110

Viber



Hydroflex Hellas A.E.

Συνδέουμε το αύριο. |